



SERVICE INSTRUCTIONS

1-800-KEATING • keatingofchicago.com

INSTALLATION FOR STAINLESS STEEL CUTTING BOARD AND PLATE SHELF WITH BRACKETS ON KEATING GRIDDLES

REQUIRED TOOLS:

- Drill Gun
- #24 Drill Bit
- Phillips Screw Driver
- 10-24 Tap

DETAIL A

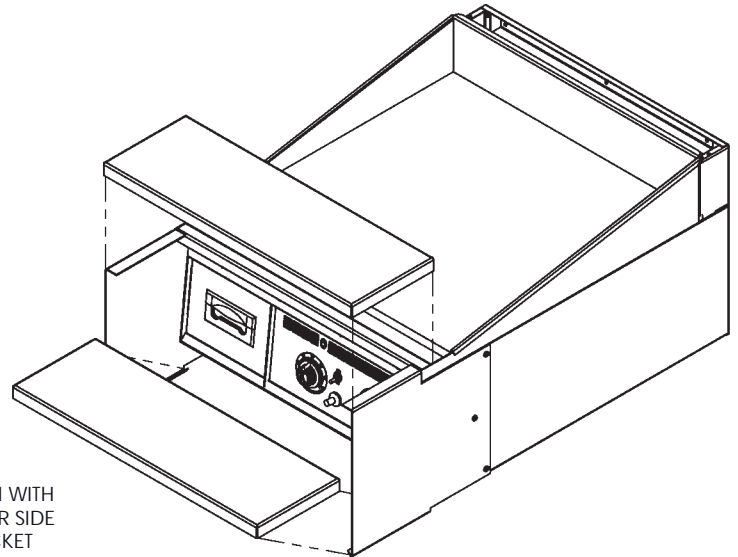
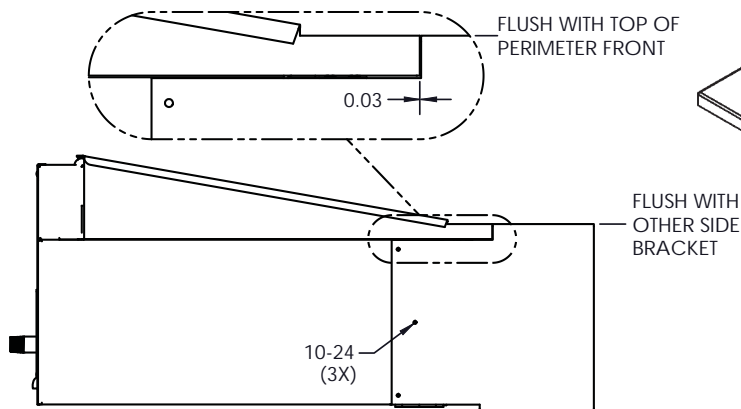

NOTE: When fully assembled, the cutting board should go over the perimeter front as well as the brackets tops.

INCLUDED IN YOUR PACKAGE:

- A** PRE-ASSEMBLED MOUNTING BRACKET FOR SECURING CUTTING BOARD TO SIDE BRACKET (2x)
- B** END SUPPORT BRACKET (2x)
- C** STAINLESS STEEL CUTTING BOARD (1x)
- D** #10 SCREWS FOR ATTACHING BRACKET TO CABINET (6x)
- E** CUTTING BOARD CENTER SUPPORT FOR 48" AND LARGER GRIDDLES (1x)
- F** STAINLESS STEEL PLATE SHELF (1x)

1. Hold the side mounting bracket in place (using orientation from detail A), and mark the mounting holes on the cabinet sides. NOTE: Bracket tops must be as flat and parallel as possible for proper mounting of the cutting board.
2. Drill out marked holes in cabinet sides using a #24 drill bit, and then tap to 10-24.
3. Attach side brackets to cabinet sides using #10 x 1/2" screws provided.
4. Slide cutting board over brackets and perimeter front as shown above.
5. Slide plate shelf between side brackets and hang on lower hooks.