



**MIRACLEAN®
GAS GRIDDLE
SERIES PRE-2000**

MANUAL

■ **IMPORTANT:**

THIS MANUAL PROVIDES SPECIFIC OPERATING INSTRUCTIONS FOR YOUR MODEL. USE THE MIRACLEAN® GAS GRIDDLE ONLY AS INSTRUCTED IN THIS MANUAL.

KEEP A COPY OF YOUR BILL OF SALE.

The date on the bill establishes the warranty period should service be required. If service is performed, it is in your interest to obtain and keep all receipts.

KEEP THIS MANUAL FOR TRAINING NEW PERSONNEL.

Record the Serial number and Model number of this Miraclean® Gas Griddle in the spaces provided. **Keep these numbers for future reference.**

SERIAL NUMBER

MODEL NUMBER

Keating commercial griddles are not intended for household use.

As continuous product improvement occurs, specifications may be changed without notice.

1-800-KEATING | keatingofchicago.com

NOTE:

PURCHASER SHOULD POST IN A PROMINENT LOCATION INSTRUCTIONS TO BE FOLLOWED IN THE EVENT THE USER SMELLS GAS. THIS INFORMATION SHALL BE OBTAINED BY CONSULTING THE LOCAL GAS SUPPLIER.



WARNING

Improper installation, adjustment, alteration, service or maintenance can cause property damage, injury or death. Read the installation, operating and maintenance instructions thoroughly before installing or servicing this equipment.



FOR YOUR SAFETY:

Do not store or use gasoline or other flammable vapors or liquids in the vicinity of this or any other appliance.

WARNING

IF NOT INSTALLED, OPERATED AND MAINTAINED IN ACCORDANCE WITH THE MANUFACTURER'S INSTRUCTIONS, THIS PRODUCT COULD EXPOSE YOU TO SUBSTANCES IN FUEL OR IN FUEL COMBUSTION WHICH CAN CAUSE DEATH OR SERIOUS ILLNESS AND WHICH ARE KNOWN TO THE STATE OF CALIFORNIA TO CAUSE CANCER, BIRTH DEFECTS OR OTHER REPRODUCTIVE HARM.

WARNING

PROPANE GAS MAY EVENTUALLY LOSE ITS ODOR AND PRECAUTIONS SHOULD BE TAKEN TO ASSURE THAT PROPANE GAS IS NOT PRESENT EVEN THOUGH YOU DO NOT DETECT AN ODOR. IF THERE IS ANY DOUBT, YOU SHOULD CALL YOUR LOCAL PROPANE GAS SUPPLIER FOR ASSISTANCE.

THE EQUIPMENT IS TO BE INSTALLED TO COMPLY WITH THE BASIC PLUMBING CODE OF THE BUILDING OFFICIALS AND CODE ADMINISTRATORS INTERNATIONAL, INC. (BOCA) AND THE FOOD SERVICE SANITATION MANUAL OF THE FOOD AND DRUG ADMINISTRATION (FDA).



■ TABLE OF CONTENTS

Important Safety Instructions	i	Shutdown	4
INTRODUCTION	1	Cooking.....	5
INSTALLATION		Cleaning.....	6
Damage During Shipment	1	PREVENTATIVE MAINTENANCE	7
FIRST STEPS	2	Preventive Maintenance Cleaning Chart	7
Positioning	2	Thermostat Calibration	8
Ventilation	2	Conditioning the Plate	8
National Code Requirement	2	Service Parts Ordering	8
Gas Connectors & Pipe Size.....	2	SERVICE DIAGNOSIS	9
Flexible Gas Connection & Quick Disconnect Devices.....	3	Troubleshooting Chart	9
Restraining Devices.....	3	Thermostat Removal and Replacement	10
Leveling.....	3	Parts List	13 - 14
Stand Assembly	3	WIRING DIAGRAM	15
PLACING YOUR KEATING GRIDDLE IN OPERATION	4	Warranty Information	16
Lighting	4		

■ INTRODUCTION

Instructions in this manual should be read thoroughly before attempting to operate this Keating Gas Griddle. All installation and service on Keating equipment must be performed by qualified, certified, licensed and/or authorized installation or service personnel.

Operating information for Keating equipment has been prepared for use by qualified and/or authorized personnel.

Keating equipment is made in the USA and has American sizes of hardware. All metric conversions are approximate.

■ INSTALLATION INSTRUCTIONS

Proper installation will assure top performance. Alterations of any kind to your equipment will void the warranty. Before uncrating, check equipment carefully for damage.

IF EQUIPMENT ARRIVES DAMAGED

Keating does not assume responsibility for loss or damage incurred in transit.

IMPORTANT

This merchandise has been thoroughly inspected and carefully packed before leaving our plant. Responsibility for its safe delivery was assumed by the carrier at the time of shipment. Claims for loss or damage to the contents should, therefore, be made upon the carrier, as follows:

CONCEALED LOSS OR DAMAGE

Concealed loss or damage means loss or damage which does not become apparent until the merchandise has been unpacked. The contents may be damaged in transit due to rough handling even though

the carton may not show external damage. When the damage is discovered upon unpacking, make a written request for inspection by the carrier's agent within fifteen days of the delivery date. Then file a claim with the carrier since such damage is the carrier's responsibility. By following these instructions carefully, we guarantee our full support of your claims to protect you against loss from concealed damage.

VISIBLE LOSS OR DAMAGE

Any external evidence of loss or damage must be noted on the freight bill or express receipt, and signed by the carrier's agent. Failure to adequately describe such external evidence of loss or damage may result in the carrier refusing to honor a damage claim. The form required to file such a claim will be supplied by the carrier.

DO NOT RETURN DAMAGED MERCHANDISE TO KEATING. FILE YOUR CLAIM AS STATED ABOVE.

■ FIRST STEPS

POSITIONING

Keep appliance area free and clear of any combustibles. Position the Keating Miraclean® Griddle 6 inches (152mm) from any combustible material. A minimum of 24 inches (610mm) should be provided at the front of the Keating Miraclean® Griddle for servicing and proper operation. Air for combustion enters the griddle from the bottom of the cabinet and the bottom of the control panel.

DO NOT BLOCK BOTTOM OF MIRACLEAN® GRIDDLE CABINET. DO NOT OBSTRUCT FLUE.

Your Keating Miraclean® Griddle is designed to be serviced from the front with adequate clearance for air openings into the combustion chamber servicing and operation.

MINIMUM CLEARANCE

CONSTRUCTION CLEARANCES		
	COMBUSTIBLE	NON-COMBUSTIBLE
BACK	6"	0"
RIGHT SIDE	6"	0"
LEFT SIDE	6"	0"

SUITABLE FOR NON-COMBUSTIBLE FLOORS

VENTILATION

The Miraclean® Griddle must be installed in an area providing adequate air supply and ventilation. Do not obstruct the flow of combustion and ventilation air. Proper ventilation is one of the important considerations for efficient operation of the Miraclean® Griddle. It should be installed so that the products of combustion are removed efficiently without producing drafts that will interfere with proper burner operation. The area around the front and bottom of the Miraclean® Griddle must be kept clear and unobstructed. In the USA, the ventilation systems must conform to the ANSI/NFPA96 latest edition. "A minimum of 18" (457mm) should be maintained between the flue outlet and the lower edge of the grease filters." It is the responsibility of the owner and the local installer to comply with national and local codes.

NATIONAL CODE REQUIREMENT

The installation must conform with local codes, or in the absence of local codes, with the National Fuel Gas code, ANSI Z223.1 or the Natural Gas Installation Code, CAN/CGA-B149.1 or the Propane Installation Code, CAN/CGA-B149.2. Flexible connectors must comply to ANSI Z221.69/CAN/CGA1.16.

Keating equipment is designed and manufactured to operate only on the type of gas specified by the user and indicated on the serial plate located inside the door. The gas may be natural, propane or manufactured. The type of gas cannot be converted to another gas fuel by turning or engaging a switch.

NOTE: NOT FOR OUTDOOR INSTALLATION.

GAS CONNECTIONS AND PIPE SIZE

The Miraclean® Griddle requires a standard gas pipe size of 3/4 inch (19mm) I.D. connection. The size of the gas supply pipe is very important. If the pipe is too small you will have low gas pressure at the Miraclean® Griddle manifold. Low gas pressure will cause slow recovery and/or delayed ignition, amongst other problems. If you have a question about gas pipe size, call your local gas company.

⚠ CAUTION

Before connecting new pipe to the Miraclean® Griddle the pipe must be blown out to remove all foreign particles. These particles in the controls or burners may cause improper or dangerous operating conditions.

⚠ CAUTION

Pipe joint compounds that are used on threaded joints of appliance piping shall be resistant to the action of liquefied petroleum gases (Loctite PST 56765). When using pipe joint compound do not apply to the first two threads. Use only a very small amount and only on male threads. This will prevent clogging of burner orifices and the gas valve. Never use compound on female threads as it might be pushed into the gas valve.

Have your installer check for gas leaks using a soap and water solution before operating.

⚠ WARNING

DO NOT USE AN OPEN FLAME TO CHECK FOR GAS LEAKS.



1. The Miraclean® Griddle and its individual shut off valves must be disconnected from the gas supply piping system during any pressure testing of that system at test pressures in excess of 1/2 psi (3.45kPa) (13.84 in WC). High pressure can damage the gas valve causing a hazardous condition.

Excessive pressure introduced to the griddle may void the warranty.

- The appliance must be isolated from the gas supply piping system by closing its individual manual shutoff valve during any pressure testing of the gas supply piping system at test pressures equal to or less than 1/2 psi (3.45 kPa).

NOTE: Line pressure must be kept below 10" (Nat), 13" (LP) during leak test to avoid damage to the gas valve.

The required gas pressure for proper operation of each Miraclean Griddle® is 4" water column for natural gas and 10" water column for propane gas at the manifold.

If more than one gas unit is on the same supply line, you may require a larger line. Consult your local gas company to assure adequate volume and pressure. Refer to serial plate for proper gas requirement for your particular model.

FLEXIBLE GAS CONNECTORS AND QUICK DISCONNECT DEVICES

For an appliance equipped with casters:

The installation shall be made with a connector that complies with the Standard for Connectors for Movable Gas Appliances, ANSI Z21.69 or the Standard for Connectors for Moveable Gas Appliances, CAN/CGA-6.16, and a quick disconnect device that complies with the Standard for Quick-Disconnect Devices for Use With Gas Fuel, ANSI Z21.41 or the Standard for Quick Disconnect Devices for Use with Gas Fuel, CAN1-6.9.

RESTRAINING DEVICES

Adequate means must be provided to limit the movement of the appliance without depending on the connector and the quick-disconnect device or its associated piping to limit the appliance movement. Griddle installation on stands with caster, casters and jam nuts must be completely tightened.

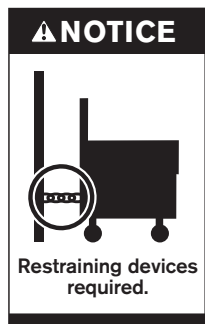

The restraint means must be attached to the rear of the Miraclean® Griddle within 2" of the center line width and approximately 1-5/8" from the bottom of the cabinet back to allow the restraining bolt to be anchored to the cabinet back between the cabinet bottom and inner liner to ensure positive support to restrain Miraclean® Griddle movement and not depend on the flexible gas connector, quick-disconnect or piping to limit the Miraclean® Griddle movement.

If disconnection of the restraint is necessary, it must be reconnected when the Miraclean® Griddle is returned to its originally installed position.

LEVELING

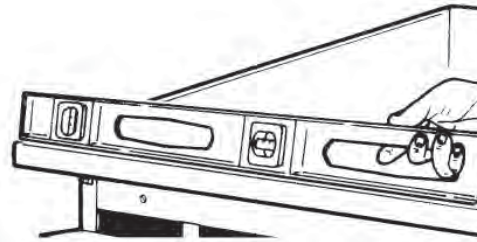

The Miraclean® Griddle will operate at its highest efficiency when properly leveled. Place a level on the Miraclean® Griddle plate from side to side. For griddles on legs, the bottom foot of the leg is adjustable. Turn counterclockwise to decrease height, or clockwise to increase height until level. For griddles on stands with casters, the casters are adjustable by loosening the jam nut. When the desired level is reached, tighten the jam nut. Adjustments of more than 3/4" are not recommended on any caster. The same procedure should be followed to level the Miraclean® Griddle from front to back.

STAND ASSEMBLY

ASSEMBLY INSTRUCTIONS FOR GRIDDLE STAND ON CASTERS (THERE IS NO TOP ON THIS STAND)

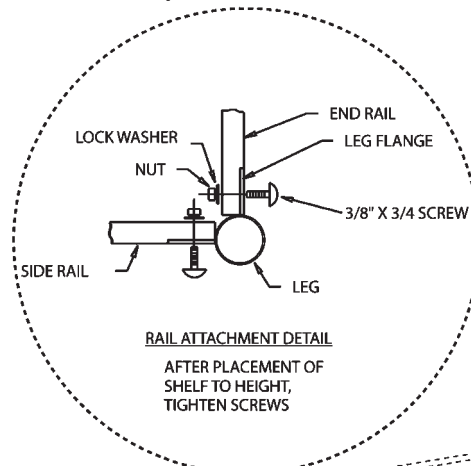

LEFT SIDE VIEW

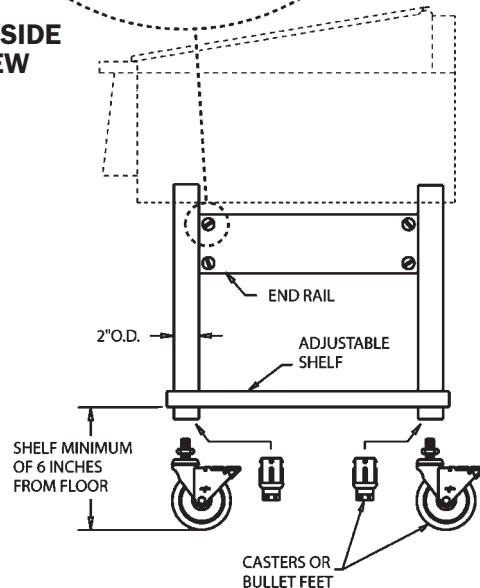

STAND ASSEMBLY

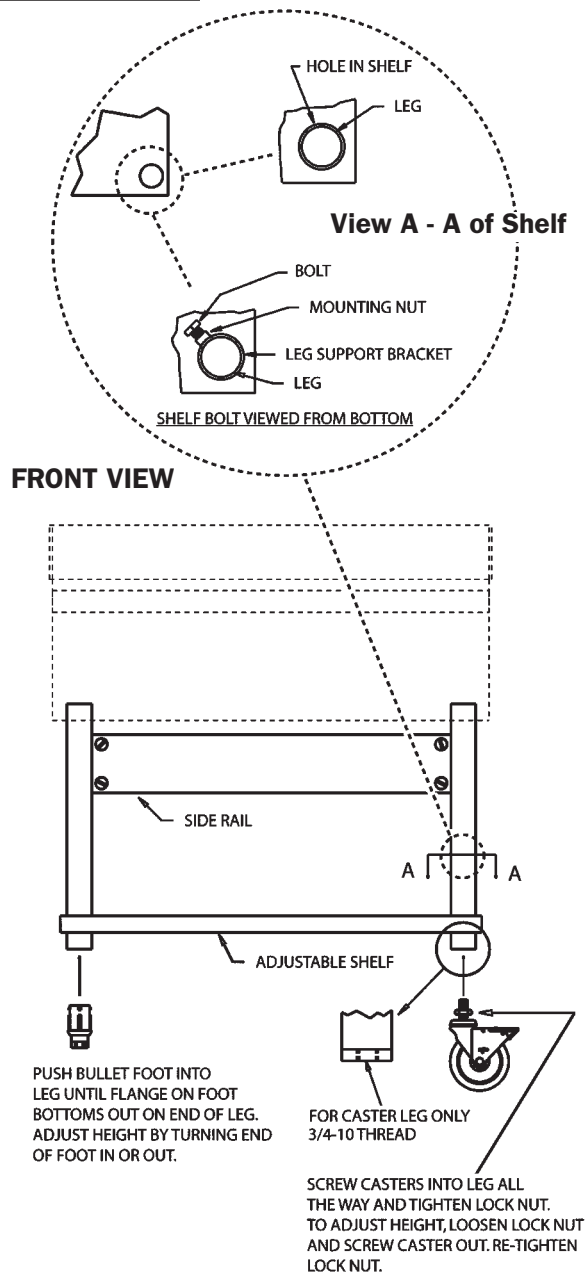

■ PLACING MIRACLEAN® GRIDDLE IN OPERATION

(When all previous instructions have been completed).

Check the serial plate to determine if the burner is set up for the proper type gas before connecting the quick-disconnect or piping from the building gas supply pipe.

- Gas pressure at manifold
NATURAL GAS – 4.0 in. W.C.
- Gas pressure at manifold
LP GAS – 10 in. W.C. (2.49kPa)
- Maximum incoming gas pressure
NATURAL GAS – 7 in. W.C. (2.01kPa)
- Maximum incoming gas pressure
LP GAS – 11 in. W.C. (2.98kPa)
- Connect incoming gas.

LIGHTING INSTRUCTIONS MIRACLEAN® GRIDDLE

(See lighting instructions plate attached to front of Miraclean® Griddle).

Make sure that the main gas valve on the gas supply line to the Miraclean® Griddle is in the "ON" position.

- Turn gas valve knob to "pilot" position.
- Push gas valve knob inwards and push the red spark ignition button to light the pilot. Then hold the knob for 90 seconds.
- Release the pilot gas valve knob; pilot should remain burning. Turn the knob to the ON position.
- Turn ON/OFF switch to ON position.
- Set thermostat knob to desired position.

AIR IN THE SUPPLY LINE MAY REQUIRE A LONGER THAN NORMAL PERIOD OF TIME TO LIGHT YOUR MIRACLEAN® GRIDDLE DURING INITIAL INSTALLATION, AFTER OVERNIGHT SHUTDOWN, OR WHEN RELIGHTING.

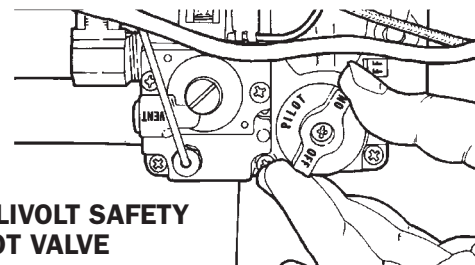

⚠ CAUTION

A 5 MINUTE COMPLETE SHUT OFF PERIOD IS REQUIRED BEFORE APPLIANCE IS RELIT

DO NOT LEAVE YOUR MIRACLEAN® GRIDDLE OPERATING UNATTENDED.

SHUT DOWN INSTRUCTIONS

- Turn ON/OFF switch to "off" position.
- Rotate thermostat knob to left to "OFF" position.
- Turn gas valve knob to "OFF" position.
- Check to determine that all burners and pilots are extinguished.

COOKING WITH YOUR MIRACLEAN® GRIDDLE

You will find that your new Miraclean® Griddle has superb heat transfer. The polished trivalent chrome finish of the Miraclean® reduces the emission of radiant heat. Radiant heat is measured by emissivity. The radiant heat of a perfect black body has an emissivity of 1. The radiant heat of a conventionally seasoned Griddle plate is approximately .87. The radiant heat of the Miraclean® has an emissivity of .078.

You can prove this to yourself by holding your hand approximately 1/2" above the Miraclean® Griddle plate. At this distance it is difficult to tell whether the Griddle plate is hot or not. It feels as though the Griddle plate is barely warm, but if you touch the plate, it will burn you.

The polished trivalent chrome finish on the Miraclean® Griddle plate is a wonderful insulator. It prevents the radiant heat from leaving the griddle plate. It transfers conducted heat to the food being cooked more rapidly than other griddle plates, because the food is placed directly on the metal surface. It is the understanding of this rapid heat transfer that permits the practical and beneficial use of the Miraclean® Griddle.

The Miraclean® Griddle finds an application in all sorts of griddle work, from cooking wheat cakes to scrambling eggs. We use these two products as illustrations because generally wheat cakes are cooked on a hot griddle. Eggs must be scrambled on a relatively cold griddle. Between these two extremes fall dozens of griddled items - everything from grilled frankfurters, grilled Italian sausage, grilled sausage patties, the entire range of steaks and chops and chicken and fish.

It is necessary to understand that the caramelization of the meat products being cooked takes place at a higher rate and at a lower griddle surface temperature because of the improved heat transfer of the Miraclean® Griddle.

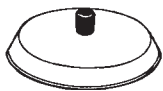

EGG COVER

Eggs can not only be scrambled, but can be fried in any fashion. If the eggs are to be basted it is necessary to have a metal cover, and to spill or splash a small amount of water under the cover so that the steam will baste the top of

the eggs. Eggs require a very low temperature because generally you do not want the eggs to be browned on the bottom where they come in contact with the griddle plate. Approximately 250°F is ideal for scrambling or frying eggs.

There are several griddle tools. A hamburger spatula is like the one pictured here. The hamburger must stick at least slightly to the griddle to hold its shape. If it does not stick it shrinks in diameter, and the center of the meat



HAMBURGER SPATULA

becomes thicker. It becomes more of a meat cake than a hamburger. Therefore, the hamburger spatula has a strong cutting edge.

An egg spatula is shown in this illustration. An egg spatula has a long very thin blade so that it can be slipped under the egg without damaging it or breaking the yolk. This spatula can also be used for chopping the scrambled eggs so as they are turned they can be cooked to perfection without unnecessary browning. This same spatula is used for omelettes.



EGG SPATULA

The Miraclean® Griddle can be kept in perfect condition by using a razor blade griddle scraper to remove the film that is deposited from the products that have been previously cooked. Eggs, being cooked at a lower temperature, require substantially no scraping; but meat and meat products cooked at a higher temperature, do require scraping. Pancakes or wheat cakes which are cooked at a much higher temperature, do not require that the Griddle be scraped. It is merely brushed clean with the spatula.



GRIDDLE SCRAPER

The important thing about the satisfactory use of the Miraclean® Griddle is to understand its rapid heat transfer at low temperatures, and to understand how to maintain the Griddle plate clean and shiny at all times.

If an accumulation builds up on the Miraclean® Griddle, it is necessary only to wash it with a palmetto pot brush and cold water. As you pour water on the Griddle and wash the Griddle with a palmetto brush, it will come clean and beautiful in but a few seconds. A scraper is used to completely remove any deposit left from previous products on the Griddle surface. Polish the Griddle so it looks new using KEATING Klenzer and a dry cloth. (See Cleaning Instructions)

COOKING PROCEDURES

MIRACLEAN® Griddles are designed to provide maximum production efficiency and deliver high quality food products. Follow cooking instructions.

MIRACLEAN® TEMPERATURE GUIDE

PRODUCT	TEMP
Bacon	325°F
Chicken Breasts (skinless)	350°F
Eggs, basted (with cover)	250° - 275°F
Eggs, scrambled	250° - 275°F
French Toast	350°F
Grilled Cheese	325°F
Hamburgers	325° - 350°F
Hot Dogs	310°F
Pancakes	360° - 370°F
Potatoes, Hash Browns	315° - 350°F
Sausage (patty or link)	315° - 325°F
Salmon (filet or steaks)	325°F
Steak, 10 oz. Butt	325°F
Steak, 6 oz. Strip	350°F

- Set the thermostat to the desired temperature and wait ten minutes for preheat. The operating temperature should be from 10°F to 25°F lower than conventional griddles – at least start at lower temperatures. You may be able to work the temperature up as you become accustomed to the more rapid cooking of the Miraclean® Griddle.
- Cook as usual, but after each batch scrape the griddle in the work area completely clean, using the 4" wide scraper supplied by Keating. (This may be the only cleaning you will ever need.)

HIGH TEMPERATURE – Since the Miraclean® Griddle does not radiate heat (for all practical purposes) sometimes people turn the griddle all the way up to 400°F. Eggs, bacon, hash browns and hamburgers will not cook on a very hot griddle. Use low temperatures and work your way up to the proper temperature.

BEST COOKING AREAS ON THE MIRACLEAN® GRIDDLE

To use the best cooking areas, locate the inverted “V’s” on the front of the griddle cooking plate. Depending on your model you may have from one to six thermostats. The “V’s” indicate where the thermostat sensing bulbs are located below the plate.

If you cook over the sensing bulb only you are drawing heat from that section; the thermostat calls for heat but since it has not dissipated in the other areas of the surface, you can overheat the griddle plate.

TOP VIEW SHOWING PLACEMENT OF BURNERS UNDER MIRACLEAN® GRIDDLE PLATE

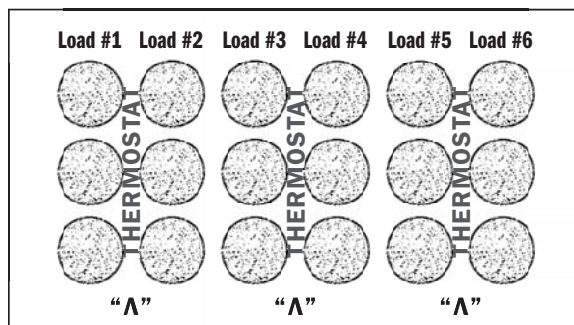
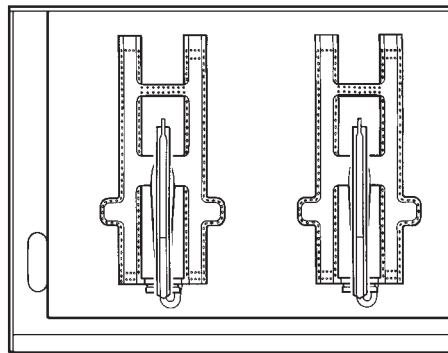

Thermostat “V” Bulb Location

- DO** cook around the thermostat sensing bulb.
- DON'T** cook directly over the thermostat sensing bulb.

CLEANING THE MIRACLEAN® GRIDDLE

The surface of the MIRACLEAN® Griddle is very durable and with proper care, following the procedures below, will last many years.

A sample of Keating Klenzer, Keating palmetto brush and a 4" scraper are included with each new griddle.

- Scrape Miraclean® surface.

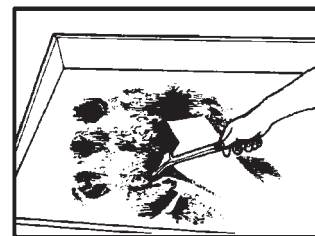

- Clean your Miraclean® Griddle while hot at 300°F to 350°F. Using a plastic pitcher, pour water ahead of a palmetto pot brush. Then scrub the griddle clean with the pot brush sweeping the water into the drain trough.

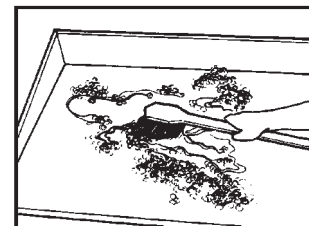

3. Sprinkle with Keating Klenzer. Polish with a soft cloth (towel). It will sparkle like new in just a few minutes. Rinse with potable water to remove excess Keating Klenzer. Proper care should be taken to fully clean the griddle on a regular basis.

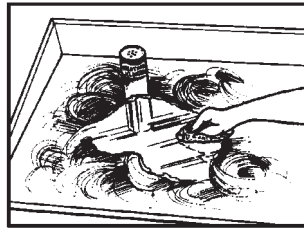

CLEANING UTENSILS

Spatulas should be hand washed in mild to medium strength detergent and towel dried. **NOTE:** Avoid contact with Chlorine or bleach, it will discolor steel spatula. Rubbing the spatula with vegetable oil will slow discoloration.

Rinse scraper and carefully wipe blade with a dry cloth. Cover blade with plastic protection cover when not in use.

Rinse Palmetto brush until clean.

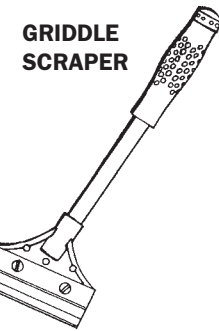

CLEANING CONTROL PANEL

Clean any grease build-up on switches and thermostat knobs.

NOTE: If grease gets into the working mechanism of a switch or thermostat, it may cause the unit to fail.

GREASE BUILD-UP NEAR ANY OPEN FLAME IS A FIRE HAZARD.



DO NOT CLEAN SCRAPER ON SPLASHBACK. GREASE BUILD-UP WILL OCCUR WHICH MAY RESULT IN A FIRE.

CLEANING CABINET

The front, back and sides of the cabinet should be kept clean for sanitary reasons.

CLEANING THE FLUE

The flue has been designed to allow the burners to burn properly. Any objects placed in the flue, such as steak weights, egg covers, pans, rags and utensils, will not allow the burners to burn properly causing poor griddle performance and health hazards.

CARE OF THE MIRACLEAN® SURFACE

The Miraclean® surface is very hard. With proper care, the Miraclean® surface and its unique cooking properties will last for many years.

CAUTION

Damage done to the Miraclean® surface is irreparable.

NEVER USE A GRIDDLE STONE, BRICK OR SCREEN TO CLEAN THE MIRACLEAN® GRIDDLE SURFACE. DAMAGE DONE TO THE MIRACLEAN® SURFACE BY GRIDDLE STONE, BRICK OR SCREEN WILL VOID THE WARRANTY.

Surface Damage

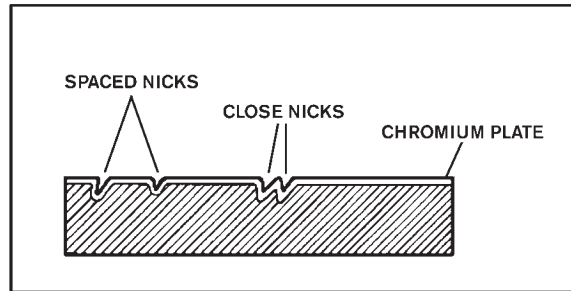

DO NOT HACK, CHOP, HIT OR CUT ON THE MIRACLEAN® SURFACE. YOU WILL DENT THE STEEL PLATE UNDER THE TRIVALENT CHROME. IT IS EVEN POSSIBLE TO HACK TWO NICKS CLOSE TOGETHER AND ACTUALLY TEAR THE MIRACLEAN® SURFACE AS THE CHROMIUM WILL NOT STRETCH. PROPER USE OF THE UTENSILS SUPPLIED WITH YOUR MIRACLEAN® GRIDDLE WILL PREVENT SURFACE DAMAGE. THE DAMAGE DONE TO THE MIRACLEAN® SURFACE IS IRREPARABLE.

NEVER USE ICE TO COOL THE MIRACLEAN® SURFACE. USE OF ICE MAY WARP THE MIRACLEAN® PLATE.

USE ONLY KEATING SUPPLIED CLEANING TOOLS AND KLENZER.

USE ONLY A KEATING STEEL SPATULA.

DO NOT WASH STEEL SPATULA WITH CHLORINE OR BLEACH AS IT WILL DISCOLOR.

THE FLUE HAS BEEN DESIGNED SPECIFICALLY TO EXHAUST THE BY-PRODUCT OF ANY COMBUSTION. ANY OBJECTS (STEAK WEIGHTS, EGG COVERS, PANS, RAGS, UTENSILS, ETC.) PLACED ON THE FLUE WILL INHIBIT THE PROPER COMBUSTION AND EXHAUST, THEREFORE CAUSING HEALTH HAZARDS.

DO NOT USE A POWER WASH, WATER JET, HOSE OR STEAM CLEANER TO CLEAN EQUIPMENT.

■ PREVENTIVE MAINTENANCE

Preventive maintenance should be done in daily, weekly, monthly and yearly intervals as necessary. Following preventive maintenance procedures will help keep your MiracleClean® Griddle working efficiently. Proper care and servicing will lead to years of quality performance.

TIME FRAME	OPERATOR/OWNER
AT LEAST DAILY	<ul style="list-style-type: none"> • Clean MiracleClean® Griddle surface. • Drain and clean grease drawer. • Completely wipe down cabinet.
AT LEAST MONTHLY*	<ul style="list-style-type: none"> • Check MiracleClean® Griddle surface to insure proper maintenance. (Review proper cooking procedures) • Check calibration of thermostats. • Review operating instructions received with MiracleClean® Griddle.
EVERY 6 MONTHS*	<ul style="list-style-type: none"> • Clean gas valve vent tube. • Check burner manifold pressure.
TIME FRAME	QUALIFIED SERVICE PERSONNEL
AT LEAST YEARLY*	<ul style="list-style-type: none"> • Have MiracleClean® Griddle completely checked, calibrated, tested, cleaned, etc. by qualified service personnel. Be sure to check color and height of pilot flame.

*High production facilities should be checked more often. Contact the factory or a local service company to perform maintenance and repairs.



DISCONNECT ALL POWER BEFORE SERVICING.

AVOID SERVICE CHECKLIST

Before calling for service, review this list. It may save you both time and expense. This list includes common occurrences that are not the result of defective workmanship or materials in this appliance.

IF MIRACLECLEAN GRIDDLE DOES NOT OPERATE:
<ul style="list-style-type: none"> • Is the gas supply turned on? • Is the gas valve knob in the ON position? • Is the pilot lit? • Is the switch turned on? • Is the thermostat set at the desired position?

WARRANTY REPAIRS

Keating's warranty begins with the date of installation. In the event that your MiracleClean® Griddle, under warranty, needs repairs other than routine cleaning, you are requested to contact KEATING OF CHICAGO, INC. (1-800 KEATING).

■ THERMOSTAT CALIBRATION

Calibration is not covered under warranty.

Tools: Accurate surface thermometer and standard screwdriver.

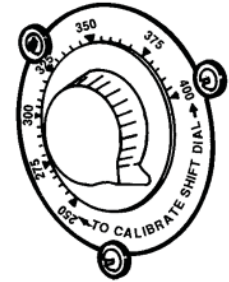

1. Turn the exhaust system ON.
2. Turn on the griddle with thermostat set at 300°F. Allow burners to cycle on and off three times. (Approximately 60 minutes.)
3. Place accurate thermometer on surface over thermostat bulb. Use the inverted "V" on the front of the griddle plate to locate thermostat bulb. Place the surface thermometer about half way toward the back of the plate.
4. When burners cycle off, the griddle is up to temperature. If temperature is within 25°F of thermostat setting, loosen the three retaining screws on the thermostat dial plate. Reset the dial plate to match the thermometer reading.
5. Tighten screws on dial plate.

For calibration over a 25°F difference, contact a qualified service company.

▲ WARNING

DO NOT ADJUST THE THERMOSTAT SET SCREW - IT VOIDS ANY WARRANTY ON PART

■ CONDITIONING THE MIRACLECLEAN® GRIDDLE PLATE

The MiracleClean® Griddle plate has been "seasoned" at the factory. The MiracleClean® surface when heated creates a thin layer of chrome oxide which acts as a releasing agent for food product. You may feel that you need to recondition your griddle surface.

1. Follow cleaning instructions on page 6.
2. Heat the MiracleClean® to 400°F for one hour.
3. Lower thermostat to 350°F, allowing the MiracleClean® to cool to about 350°F, as is evident when griddle cycles on or surface thermometer indicates correct temperature.
4. Lightly coat the MiracleClean® surface with griddle oil.

NOTE: Despite the food releasing properties, the chrome surface is not a true "non-stick" surface. For best cooking results and product appearance, use griddle oil for products that require the surface to be conditioned.

■ SERVICE PARTS ORDERING

Parts may be ordered by part number by calling Keating at 1-800-KEATING or your service company. We recommend using genuine Keating Replacement Parts - engineered and manufactured specifically to meet exact specifications and requirements for Keating equipment.

Refer to the Keating Miraclean® Griddle Limited Warranty for complete service and ordering information. The model/serial plate is located inside the cabinet. Remove grease drawer. The model and serial numbers are necessary when ordering.

■ SERVICE DIAGNOSIS

The following diagnosis is only to be used as a guide to qualified service personnel. Keating recommends that you use a qualified & licensed service company. (Equipment still under warranty requires it.)

NOTE: To correctly and quickly diagnose the system, the chart below should be followed in sequential order.

TROUBLE SHOOTING CHART

PROBLEM	PROBABLE CAUSE	SOLUTION
No pilot	<ul style="list-style-type: none"> a. Gas supply not "ON". b. Air in gas lines. c. Quick disconnect not engaged. d. Gas valve is on "OFF" position. e. Faulty piezo ignitor. 	<ul style="list-style-type: none"> a. Open gas supply valve. b. Press gas valve knob in "pilot" position and hold. c. Reconnect quick disconnect. d. Turn valve knob to "pilot". e. Replace ignitor.
Pilot won't stay on	<ul style="list-style-type: none"> a. Loose wires. b. Faulty thermopile. c. Inadequate gas supply. d. Bad gas valve. 	<ul style="list-style-type: none"> a. Tighten connections on all wires. b. Replace thermopile. c. Increase line pressure. d. Replace gas valve.
Pilot on but no main burner ignition	<ul style="list-style-type: none"> a. ON/OFF switch is in "OFF" position. b. Gas valve is in "pilot" position. c. Thermostat is not turned on. d. Low gas pressure. e. Gas valve failure. 	<ul style="list-style-type: none"> a. Put ON/OFF switch in "ON" position. b. Turn knob to "ON" position. c. Turn thermostat to desired temperature. d. Set manifold pressure to 4" WC (nat), 10" WC (LP). e. Replace valve.
Temperature of griddle is erratic	<ul style="list-style-type: none"> a. Thermostat is not calibrated. b. Air from exhaust hood excessive. 	<ul style="list-style-type: none"> a. Calibrate thermostat with exhaust system running. b. Have exhaust hood inspected and air flow balanced.
Griddle stays hot or overheats	<ul style="list-style-type: none"> a. Thermostat is not calibrated. b. Thermostat failure. c. Air from exhaust hood excessive. d. Improper cooking procedure. 	<ul style="list-style-type: none"> a. Calibrate thermostat. b. Replace thermostat. c. Have exhaust hood inspected and air flow balanced. d. See Cooking Procedure Section.
Burners will not shut off	<ul style="list-style-type: none"> a. Thermostat is not calibrated. b. Thermostat failure. c. Bad gas valve. 	<ul style="list-style-type: none"> a. Calibrate thermostat. b. Replace thermostat. c. Replace gas valve.
Flames pulsate	<ul style="list-style-type: none"> a. Low gas pressure. b. Orifice is dirty or clogged. c. Air from exhaust hood excessive. 	<ul style="list-style-type: none"> a. Set manifold pressure to 4" WC (nat), 10" WC (LP). Set line pressure to 7" WC (nat), 11" WC (LP). b. Clean orifice. c. Have exhaust hood inspected and airflow balanced.

SERVICE

Servicing should only be performed by qualified & licensed service companies.

GAS VALVE REGULATOR ADJUSTMENT

Recommended gas pressure at manifold (4.0" W.C. Natural gas 10.0" W.C. Propane gas)

Adjustment of the gas valve pressure regulator is not normally necessary since it has been preset at the factory. During installation, the gas pressure should be checked at each gas valve with all burners operating. Adjustment may be accomplished as follows:

NOTE: This adjustment must be performed by a qualified technician.

1. Locate the gas valves.
2. With the griddle turned off, connect the monometer to the pressure tap on the gas valve to be tested.
3. Turn the unit on and take the reading after all the burners have ignited.
4. Make the necessary adjustments by removing the screw cap on the pressure regulator cover exposing the adjustment screw (clockwise will increase the pressure, counterclockwise will decrease the pressure).

Always check the screw cap on the pressure tap for leaks after it has been removed and replaced.

GAS VALVE REMOVAL AND REPLACEMENT

Disconnect the griddle from the gas supply.

1. Lower the control panel. Remove the control panel surround and upper heat shield.
2. Remove the three wires connected to the gas valve.
3. Disconnect the pilot and burner feed from the front of the gas valve.
4. Access the pipe union at the rear of the gas valve either from the front of the griddle or remove the back of the cabinet and loosen the union.
5. Remove two nuts on the rear of the gas manifold and pull the gas manifold forward.
6. Remove the gas valve and transfer the pipe and fittings to the new gas valve. Transfer the pressure tap to the new gas valve.
7. Replace the gas valve by reversing the above steps.

Always check for leaks at all joints and connections using a soap solution mixed with water.

DO NOT USE AN OPEN FLAME TO CHECK FOR GAS LEAKS

Double check the wire connections to the gas valve; improper connection could damage the gas valve.

ON/OFF SWITCH REMOVAL AND REPLACEMENT

1. Lower the control panel by removing the screws.
2. Disconnect the wires on the switch and remove switch.
3. Snap the new switch into place and reconnect all wires.
4. Return the control panel to its normal position.

THERMOSTAT REMOVAL AND REPLACEMENT

1. Lower the control panel by removing the mounting screws.
2. Locate the bulb end of the thermostat and, using a wrench, loosen the front and rear bolts holding the thermostat bulb and shield in place.
3. Slide the thermostat bulb assembly towards you and remove it from under the griddle plate.
4. Remove the knob and the screws from the thermostat dial plate on the control panel.
5. Remove the body of the thermostat.
6. Install the new thermostat in the control panel, replace the dial plate.
7. Slide the thermostat bulb assembly into the channel until it reaches the stop.
8. Make sure that the thermostat capillary and bulb are completely protected by the shield, except for 1" at the tip of the thermostat bulb. (See Note 1).
9. Make sure that the thermostat shield extends to the front edge of the plate, and that the capillary goes through the formed end of the shield. (See Note 2).
10. Make sure that the bolts which hold the thermostat bulb and shield in place do not touch the thermostat bulb. (See Note 3).

Tighten bolts 1/4 turn past finger tight bulb to be snug against the bottom of the plate.

DO NOT OVERTIGHTEN THE BOLTS ON THE THERMOSTAT SHIELD OR THEY WILL CRUSH THE THERMOSTAT BULB.

11. Close the control panel and replace the panel mounting screws.

NOTE: IF REPLACING PUSH-ON TERMINAL STYLE. Before installing thermostat into control panel, you must unscrew the two brass terminal screws and install the new ring terminal wire connectors. Prior to connecting these wires, the existing push-on terminal must be cut off and ring terminals installed on them. Make sure that the terminals are secured down.

12. Calibrate the thermostat using an accurate griddle thermometer. Locate the thermometer over the thermostat bulb (shown by the "L" on the front of the griddle plate) about half way toward the back of the plate. Calibrate to the cooking temperature you will be setting on the thermostat.

THERMOSTAT BULB PLACEMENT DETAIL

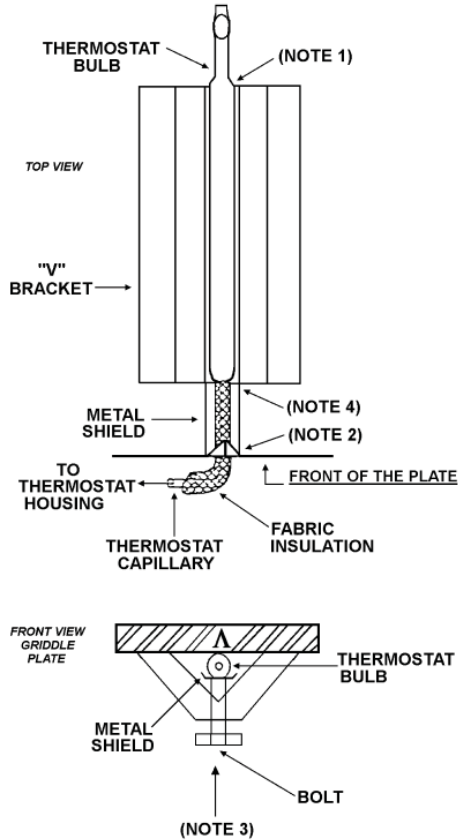

MILLIVOLT CHECK (FOR QUALIFIED SERVICE TECHNICIANS ONLY)

The millivolt valve is a thermopile self-powered combination gas control. Before checking the millivolt system, the following operations should be performed and observations made:

1. A genuine Keating millivolt thermostat should be used for millivolt operation.
2. The thermostat leads and all wire connections should be cleaned and tightened to eliminate all unnecessary resistance.
3. If pilot will not remain lit when gas valve knob is released, check automatic pilot.

NOTE: The millivolt system and individual components may be checked with a millivolt meter having a 1-1000MV range. Conduct each check below by connecting meter test leads to terminals as indicated. All readings are closed circuit.

(REFER TO CHART BELOW)

A. BURNER COIL CHECK

("A" Reading. Thermostat contacts CLOSED - Gas Valve knob "ON". Main burner should come ON.)

1. If the reading is more than 100 millivolts and the automatic valve still does not come one, replace the valve.
2. If the closed circuit reading ("A" reading) is less than 100 millivolts, determine cause for low reading and proceed as follows:

B. THERMOPILE OUTPUT CHECK

("B" Reading. Thermostat contacts OPEN - Main burner OFF.)

1. Thermopile system - 325 millivolts minimum. If the minimum millivolt reading is not obtainable, readjust thermopile for maximum millivolt output. If millivolt reading is still below minimum specified, replace thermopile.

C. THERMOSTAT RESISTANCE CHECK

("C" Reading. Thermostat contacts CLOSED - Gas valve knob "ON". Main burner should be ON.)

1. If the "C" reading is above 80 millivolts, the resistance in the system is excessive and must be reduced. To correct:
 - a. Clean and tighten thermostat leads and connections.
 - b. Shorten or replace thermostat lead wires.
 - c. Cycle thermostat rapidly (manually turn dial) to clean contacts.

D. AUTOMATIC PILOT DROPOUT CHECK

1. Hold gas valve knob depressed in pilot position until maximum output is observed. Then extinguish pilot and observe meter.
2. Dropout of automatic pilot magnet (sound should be audible) should occur between 120 millivolts and 30 millivolts. If dropout occurs outside these limits, change the valve.

CHECK	TO TEST	CONNECT METER LEADS TO TERMINALS		THERMOSTAT CONTACTS	METER READING SHOULD BE:
A	MILLIVOLT SYSTEM CHECK	TP	TH	CLOSED	100mV OR MORE
B	THERMOPILE OUTPUT	THTP	TP	OPEN	BETWEEN 325-700mV
C	SYSTEM RESISTANCE CHECK	THTP	TH	CLOSED	MEASURE LESS THAN 80mV
D	AUTOMATIC PILOT DROPOUT	THTP	TH	OPEN	BETWEEN 120mV-30mV

MILLIVOLT CONTROL VALVE

To check Resistance of the gas valve, connect one wire to the valve as shown.

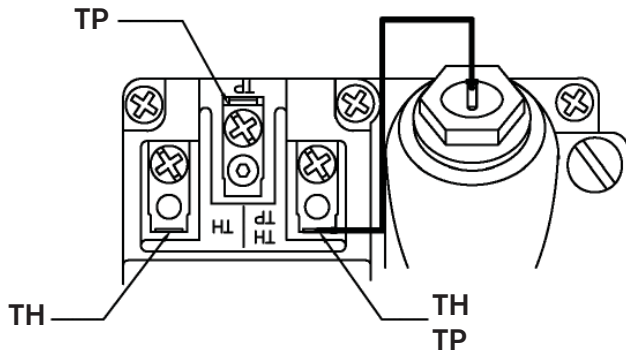

1. Resistance between the THTP & TH terminals must be $11.5\Omega \pm 0.2\Omega$

2. Resistance between the THTP & TP terminals must be $10.0\Omega \pm 0.2\Omega$

If resistance is outside of specifications listed, the gas valve must be replaced.

BEFORE REPLACING THERMOPILE CHECK MILLIVOLT READINGS

THERMOPILE READINGS

With all wires connected, with the pilot on and burners off, the thermopile reading at the TP&THTP terminals should be ~325mv. With the burners on, the millivolt reading should be ~200mv.

WARNING AND OPERATING PLATES

All warning and operating plates on the Keating Miraclean® Griddle should be in place at all times. If plates are damaged or lost, replace them immediately.

■ PARTS LIST - MIRACLEAN GRIDDLE

MIRACLEAN GRIDDLE ASSEMBLY

Figure 6-1

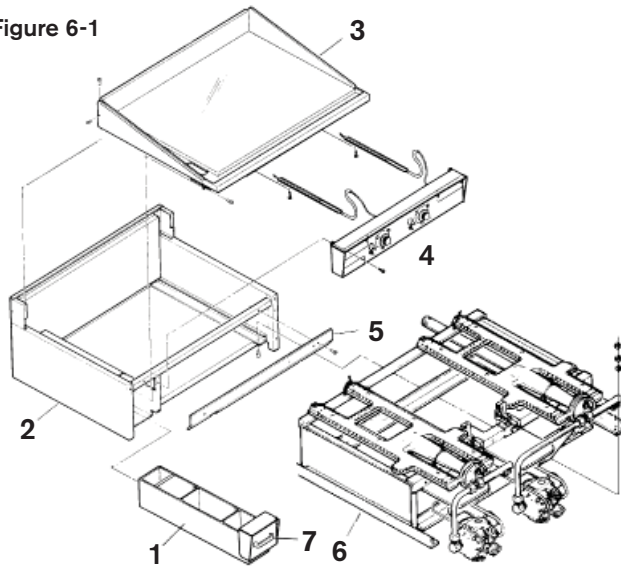

ITEM	DESCRIPTION	P/N
1	GREASE DRAWER ASSEMBLY 24" DEEP GRIDDLES	004013
	30", 33", 36" DEEP GRIDDLES	002446
2	CABINET (REFERENCE ONLY)	
3	PLATE AND PERIMETER	1-800-KEATING
4	CONTROL PANEL ASSEMBLY	SEE Figure 6-2
5	HEAT SHIELD	1-800-KEATING
6	BURNER INSERT	SEE PAGE 14
7	GREASE DRAWER HANDLE	004542

CONTROL PANEL ASSEMBLY

Figure 6-2

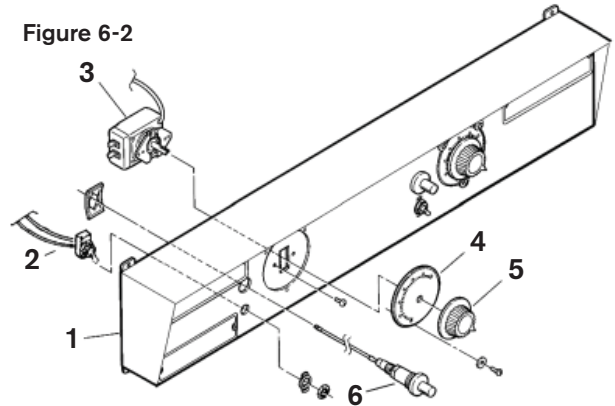

ITEM	DESCRIPTION	P/N
1	CONTROL PANEL	1-800-KEATING
2	THERMOSTAT "ON/OFF" SWITCH WITH WIRES	009345
3	THERMOSTAT 250° - 400°F	017370
	THERMOSTAT 150° - 550°F	023897
	THERMOSTAT REPLACEMENT KIT FOR 400°F + - STAT	037088
4	THERMOSTAT DIAL PLATE 250°-400°F	
	250° - 400°F	034870
	200° - 500°F	060105
5	THERMOSTAT KNOB 400°F	060612
	THERMOSTAT KNOB 550°F	038368
6	PIEZO SPARK IGNITOR ASSEMBLY	
	A. MOUNTED ON LEFT, 45° BRACKET. USED ON ALL NATURAL GAS STANDARD GRIDDLES AS WELL AS 27" AND 30" LEFT SIDE ON SINGLE BURNER PROPANE GRIDDLES.	010946
	B. MOUNTED ON RIGHT, 45° BRACKET. USED ON BEF 36" & 27" AND 30" RIGHT SIDE GRIDDLES.	002556
	C. CENTER MOUNT, 90° BRACKET. USED ON ALL PROPANE GRIDDLES WITH MORE THAN TWO BURNERS (42" AND UP). FOR BAT WING PILOT.	010365
	D. NO MOUNTING BRACKET. USED ON PROPANE GRIDDLES WITH 2 OR LESS BURNERS, 24", 27", 30", 36" ON RIGHT SIDE.	008327
	E. NO MOUNTING BRACKET. MOUNTS ON PILOT BRACKET.	010364

■ PARTS LIST - MIRACLEAN GRIDDLE (cont.)

Natural and Propane Gas Heating Systems

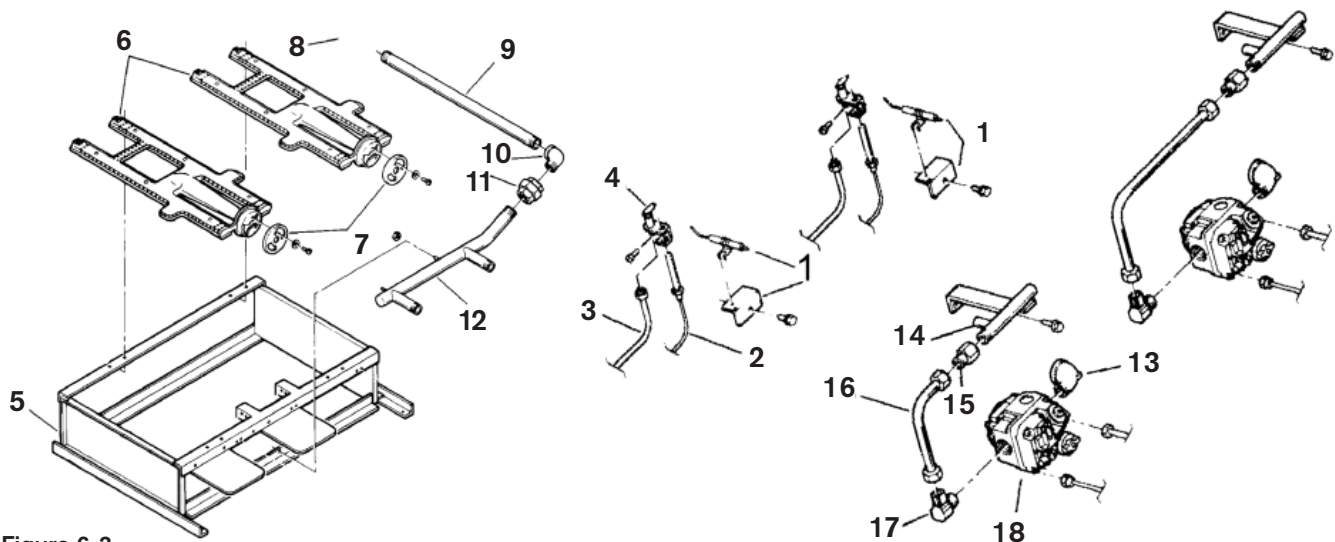
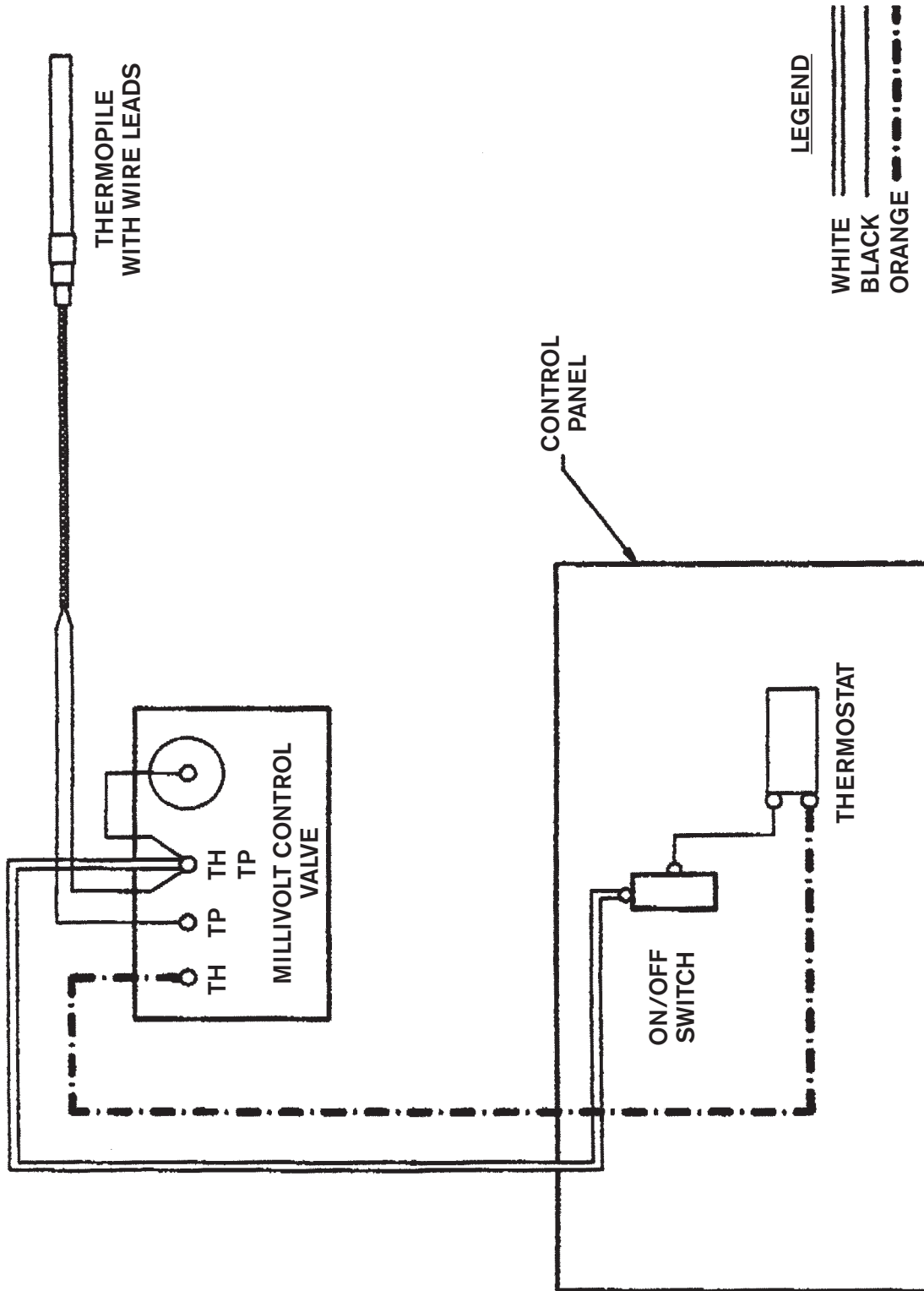

Figure 6-3

ITEM	DESCRIPTION	P/N
1	SPARK IGNITION ASSEMBLY SEE ITEM 6, Figure 6-2	
2	THERMOPILE	022770
3	PILOT TUBE (1/4")	007998
4	PILOT ASSEMBLY	029769
	ALL NATURAL GAS, 24" - 30"	
	LP, 24" - 39" BEF	
	NATURAL GAS ORIFICE	007696
	PROPANE ORIFICE	007766
	COMPRESSION SLEEVE	029599
5	BURNER INSERT (REFERENCE ONLY)	
6	BURNER (REFERENCE ONLY)	
7	AIR SHUTTERS	031477
8	MAIN SUPPLY GAS VALVE 3/4" (NOT SHOWN)	019515
9	MAIN GAS PIPE 3/4" (REFERENCE ONLY)	
10	STREET ELBOW 3/4"	005738
11	UNION	002658
12	MANIFOLD	1-800-KEATING
13	STREET ELBOW 1/2"	004194
14	ORIFICE HOLDER ASSEMBLY (REFERENCE ONLY)	
15	FITTING (IF ELBOW)	006477
	FITTING (IF STRAIGHT)	006473
16	BURNER TUBE (1/2" x 9")	1-800-KEATING
17	ELBOW (1/2" x 3/8")	002462
	STRAIGHT	000615
18	GAS VALVE, MILLIVOLT	
	NAT.	023625
	L.P.	023624

■ WIRING DIAGRAM

GAS GRIDDLE WIRING DIAGRAM





WARRANTY

LIMITED WARRANTY

Keating of Chicago, Inc. ("Keating") warrants to the original purchaser, ("Customer"), all new Keating Fryers, Filter Systems, Griddles, Keep Krisp[®], Custom Pasta Systems, Top-Side[™] Cookers, Computer Timers, Fryer & Pasta Vessels and Keating replacement parts ("products") installed after June 1, 1994 to be free to defects in material or workmanship, subject to the following terms and conditions.

LENGTH OF WARRANTY

All products other than Fryer & Pasta Vessels and replacement parts shall be warranted for a period of one year from the date of original equipment installation. Keating replacement parts are warranted for a period of ninety days from the date of installation. Fryer & Pasta Vessels are warranted as described below.

FRYER & PASTA VESSEL WARRANTY

Fryers purchased after June 1, 1994 carry a prorated vessel warranty on defects in materials or workmanship to the Customer based on the following scale:

Time from Installation Date	Fryer Vessel Warranty Credit
13-60 months	100%
61-72 months	80%
73-84 months	60%
85-96 months	40%
97-108 months	20%
109-120 months	10%

The credit for the defective fryer & pasta vessel shall be applied against the cost of the replacement vessel, utilizing Keating's then current price, upon return of the vessel to Keating only during the first 60 months, subject to the limitations described below.

LIMITATIONS OF LIABILITY

In the event of warranty claim or otherwise, the sole obligation of Keating shall be the repair and / or replacement at the option of Keating of the product or component part thereof. Such repair or replacement shall be at the expense of Keating except that the Customer shall pay the following expenses: all freight and labor expense for Keating replacement parts; for all other products, mileage exceeding 50 miles or travel more than one hour, labor costs of more than one person, overtime rates, truck charges, difference between ground and other mode of transportation, and holiday charges. Any repair or replacement under this Limited Warranty does not constitute an extension of the original warranty for any period for the product or for any component or part thereof. Parts to be replaced under this Limited Warranty will be repaired at the option of Keating with new or functionally operative parts. Keep Krisps and Computer Timers must be returned to Keating for warranty repair or replacement. Field repairs of those items are not authorized.

THE LIABILITY OF KEATING ON ANY CLAIM OF ANY KIND, INCLUDING CLAIMS BASED ON WARRANTY, EXPRESSED OR IMPLIED, CONTRACT, NEGLIGENCE, STRICT LIABILITY OR ANY OTHER THEORIES SHALL BE SOLELY AND EXCLUSIVELY THE REPAIR OR REPLACEMENT OF THE PRODUCT AS STATED HEREIN, AND SUCH LIABILITY SHALL NOT INCLUDE, AND CUSTOMER SPECIFICALLY RENOUNCES ANY RIGHTS TO RECOVER, SPECIAL, INCIDENTAL, CONSEQUENTIAL OR OTHER INJURIES TO PERSONS OR DAMAGE TO PROPERTY, LOSS OF PROFITS OR ANTICIPATED PROFITS, OR LOSS OF USE OF THE PRODUCT.

If any oral statements have been made regarding the Keating products, such statements do not constitute warranties and are not part of the contract sale. This Limited Warranty constitutes the complete, final and exclusive statement with regard to warranties.

THIS LIMITED WARRANTY IS EXCLUSIVE AND IS IN LIEU OF ALL OTHER WARRANTIES WHETHER WRITTEN, ORAL, STATUTORY OR IMPLIED, INCLUDING BUT NOT LIMITED TO ANY WARRANTY OF MERCHANTABILITY OR FITNESS FOR PARTICULAR PURPOSE OR WARRANTY AGAINST LATENT DEFECTS.

EXCLUSIONS

The warranties provided by Keating of Chicago, Inc. do not apply in the following instances:

1. Defects arising out of or resulting from improper installation or maintenance, abuse, misuse, modification or alteration by unauthorized service personnel, or any other condition not attributable to a defect in material or workmanship. Proper installation and maintenance are the responsibility of the installer and Customer, respectively. Proper installation and maintenance procedures are prescribed by the Keating Service Manual.
2. In the event that the product was damaged after leaving the factory due to flood, fire, other acts of God or accident, damaged during shipment should be reported to the carrier and is not the responsibility of Keating.
3. In the event the serial number or rating plate has been removed from the product or altered.
4. On parts which would normally be worn or replaced under normal conditions, including but not limited to electric bulbs, fuses, interior and exterior finishes, gaskets and radiants.
5. With regard to adjustments and calibrations such as leveling, tightening of fasteners or plumbing connections, improper gas pressure or improper electrical supply, the checking of and changes in adjustment and calibrations are the responsibility of the installer. Proper installation procedures are prescribed by the Keating Service Manual.
6. In the event of unauthorized repairs or alterations to the Keating product.
7. With the use of sodium chloride in pasta vessels or harsh chemicals in fryer or pasta vessels.
8. Installation in Household.

OTHER TERMS AND CONDITIONS

The Customer must provide proof of purchase from Keating.

This Limited Warranty is valid in the 50 United States, its territories, and Canada, and is void elsewhere. Keating products are sold for commercial use only. If any Keating product is sold as a component of another product or used as a consumer product, such Keating product is sold As Is without any warranty.

If any provision of this Limited Warranty is held to be unenforceable under the law of any jurisdiction, such provision shall be inapplicable in such jurisdiction, and the remainder of the warranty shall remain unaffected. Further in such event, the maximum exclusion or limitation allowable under applicable law shall be deemed substituted for the unenforceable provision.

This Limited Warranty shall be governed by and construed in accordance with the laws of the State of Illinois.

TO SECURE WARRANTY SERVICE

All repair services under this Limited Warranty must be authorized by Keating or performed at Keating. Authorization may be obtained by calling 1-800-KEATING within the Continental United States, Alaska, Hawaii, Puerto Rico and Canada during normal business hours (8 a.m. through 5 p.m. Central Time, Monday through Friday). When calling, please have the following information available: (1) name, address and telephone number of the Customer; (2) location of product, if different; (3) name, model number and serial number of the product; (4) installation date; and (5) description of defect. Keating will then issue a service authorization work order number to one of its approved independent servicing organizations, or request the product or part be shipped to Keating for repair or replacement, as appropriate. Any defective part subject to a claim under this Limited Warranty must be shipped freight prepaid to Keating for testing and examination. Keating's decision as to the cause and nature of any defect under this Limited Warranty shall be final.

■ **SERVICE INFORMATION:**

If you have a service related question call **1-800-KEATING**.
Please state the nature of the call; it will ensure speaking with the appropriate person.

Have your serial and model number available when ordering parts.

As continuous product improvement occurs, specifications may be changed without notice.

.....
KEATING LIMITED WARRANTY CARD

PLEASE COMPLETE AND MAIL AT ONCE--WARRANTY IS NOT IN EFFECT UNTIL CARD IS RETURNED, OR COMPLETE THE WARRANTY CARD ON OUR WEBSITE FOR YOUR CONVENIENCE.

COMPANY: _____

ADDRESS: _____

CITY: _____ STATE: _____ ZIP CODE: _____

DEALER NAME: _____

DATE OF PURCHASE: _____ INVOICE #: _____

SERIAL #: _____ MODEL: _____

FRYER GRIDDLE CUSTOM PASTA
 FILTER SYSTEM TOP-SIDE COOKER HOTPLATE

I HAVE READ THE INSTALLATION AND OPERATING INSTRUCTIONS.

SIGNED: _____ DATE: _____



KEATING OF CHICAGO, INC.
8901 West 50th Street
McCook, IL 60525-6001

1-800-KEATING
PHONE: 708-246-3000
FAX: 708-246-3100

Serving Those Who Serve the Very Best®