



**INSTANT RECOVERY®
ELECTRIC FRYER
SERIES PRE-2000**

MANUAL

IMPORTANT:

THIS MANUAL PROVIDES SPECIFIC OPERATING INSTRUCTIONS FOR YOUR MODEL. USE THE INSTANT RECOVERY® ELECTRIC FRYER ONLY AS INSTRUCTED IN THIS MANUAL.

KEEP A COPY OF YOUR BILL OF SALE.

The date on the bill establishes the warranty period should service be required. If service is performed, it is in your interest to obtain and keep all receipts.

KEEP THIS MANUAL FOR TRAINING NEW PERSONNEL.

Record the Serial number and Model number of this Instant Recovery® Electric Fryer in the spaces provided. **Keep these numbers for future reference.**

SERIAL NUMBER

MODEL NUMBER

Keating commercial fryers are not intended for household use.

As continuous product improvement occurs, specifications may be changed without notice.

1-800-KEATING | keatingofchicago.com

NOTE:

PURCHASER SHOULD POST IN A PROMINENT LOCATION.

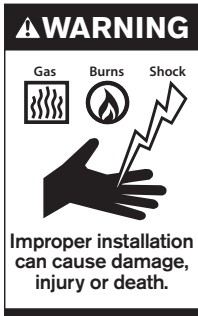

⚠ WARNING

Improper installation, adjustment, alteration, service or maintenance can cause property damage, injury or death. Read the installation, operating and maintenance instructions thoroughly before installing or servicing this equipment.



FOR YOUR SAFETY:

Do not store or use gasoline or other flammable vapors or liquids in the vicinity of this or any other appliance.

THE EQUIPMENT IS TO BE INSTALLED TO COMPLY WITH THE BASIC PLUMBING CODE OF THE BUILDING OFFICIALS AND CODE ADMINISTRATORS INTERNATIONAL, INC. (BOCA) AND THE FOOD SERVICE SANITATION MANUAL OF THE FOOD AND DRUG ADMINISTRATION (FDA).



■ TABLE OF CONTENTS

Important Safety Instructions i

INTRODUCTION 1

INSTALLATION

Damage During Shipment 1

Standard Features 2

Safety Precautions 2

FIRST STEPS

Positioning 3

Leveling 3

Restraining Devices 4

Electrical Connection 4

OPERATING

Filling 4

Melting 4

Cooking 5 - 6

Shutdown 6

Draining 6

Cleaning and Boil-Out 6

Electronic Timers 7 - 8

PREVENTATIVE MAINTENANCE

Warranty Repairs 9

Preventive Maintenance Chart 9

Oil Breakdown 9

Limited Calibration 10

Thermostat Bulb Positioning..... 10

Hi-Limit Check..... 10

SERVICE DIAGNOSIS

Troubleshooting Chart..... 11 - 12

ORDERING PARTS

Service Parts Ordering 12

Warning and Operating Plates 12

PARTS LIST 13

Electric Fryer Parts List & Assembly 13 - 14

BB Control Panel Parts List 15

TS Control Panel Parts List..... 16

10x11", 14" Basket-Lift Control Panel 17

18 - 34x24" Basket-Lift Control Panel 18

14" Basket-Lift Housing and Roller Guide Parts 19

18 - 34x24" Basket-Lift Housing, Roller Guide and
Transformer Box Parts List 20

WIRING DIAGRAMS 21 - 25

BB Wiring Diagram 21

TS Wiring Diagram 22 - 23

Basket-Lift Wiring Diagram 24 - 25

FRYER SPECIFICATIONS

BB Models..... 26

TS Models 27

Warranty Information 28

■ INTRODUCTION

Instructions in this manual should be read thoroughly before attempting to operate this Keating Electric Fryer. All installation and service on Keating equipment must be performed by qualified, certified, licensed and/or authorized installation or service personnel.

Operating information for Keating equipment has been prepared for use by qualified and/or authorized personnel.

Keating equipment is made in the USA and has American sizes of hardware. All metric conversions are approximate.

■ INSTALLATION INSTRUCTIONS

Proper installation will assure top performance. Alterations of any kind to your equipment will void the warranty. Before uncrating, check equipment carefully for damage.

IF EQUIPMENT ARRIVES DAMAGED

Keating does not assume responsibility for loss or damage incurred in transit.

IMPORTANT

This merchandise has been thoroughly inspected and carefully packed before leaving our plant. Responsibility for its safe delivery was assumed by the carrier at the time of shipment. Claims for loss or damage to the contents should, therefore, be made upon the carrier, as follows:

CONCEALED LOSS OR DAMAGE

Concealed loss or damage means loss or damage which does not become apparent until the mer-

chandise has been unpacked. The contents may be damaged in transit due to rough handling even though the carton may not show external damage. When the damage is discovered upon unpacking, make a written request for inspection by the carrier's agent within fifteen days of the delivery date. Then file a claim with the carrier since such damage is the carrier's responsibility. By following these instructions carefully, we guarantee our full support of your claims to protect you against loss from concealed damage.

VISIBLE LOSS OR DAMAGE

Any external evidence of loss or damage must be noted on the freight bill or express receipt, and signed by the carrier's agent. Failure to adequately describe such external evidence of loss or damage may result in the carrier refusing to honor a damage claim. The form required to file such a claim will be supplied by the carrier.

DO NOT RETURN DAMAGED MERCHANDISE TO KEATING. FILE YOUR CLAIM AS STATED ABOVE.

STANDARD FEATURES

- Highly polished stainless steel fryer vessel
- Highly polished stainless steel front
- Highly polished stainless steel elements
- Highly polished stainless steel thermostat bulb
- Highly polished stainless steel Hi-Limit sensor
- True Cold Zone for proper sedimentation
- Grid screen over elements
- Melt cycle
- 1" full port front drain valve on 10x11 and 14; 1-1/4" for 18 and larger
- High temperature limit control with manual reset
- Patented accurate temperature control system $\pm 7^{\circ}\text{F}$
- Ideal 35" working height
- One pair of split baskets or one full-size basket (18" model only)
- Circuit breaker protection for 208-240V 10x11 to 34x24 Models

STANDARD ACCESSORIES

- Keating Klenzer Sample
- Drain clean out rod

STANDARD FRYERS

- Sizes: 10x11 to 34x24
- Oil capacity 30 to 210 pounds
- NSF, ETL and ETLs listed

MODEL VARIATIONS

BB Model: BB Model Fryers feature Power On and Element On indicating lights, a melt cycle and an electric stainless steel thermostat. The 14BB model can cook up to 72 lbs. of frozen fries or 75 lbs. of chicken per hour.

TS Model: TS Model Fryers have the highest input of all Keating fryers. The TS Model features a melt cycle, an electric stainless steel thermostat, two electronic timers and four indicating lights which display the status of the fryer's operation. The 14TS Model can cook up to 90 lbs. of frozen fries or 75 lbs. of chicken per hour.

TS Basket-Lift Model: TS Basket-Lift Model Fryers come with all the same features as the TS Model. The Basket-Lift mechanism lowers the baskets of food into the oil when the timer button is pressed and raises the baskets when the cooking cycle is complete. Split baskets are used for all models.

CM Model: BB and TS Counter Model Fryers are equipped with all of the same features as the BB and TS Models respectively, but take up less than three square feet of counter space. The 10x11CM Model can cook up to 36 lbs. of frozen fries per hour and the 14CM Model can cook up to 72 lbs. per hour.

CPU Model: CPU Model Fryers have the same input as the TS Models, and features an over max temperature light. A programmable computer replaces the two timers and thermostat.

SAFETY PRECAUTIONS

⚠WARNING

THIS SYMBOL WARNS YOU THAT SERIOUS BURNS OR OTHER INJURIES MAY RESULT IF SAFETY INSTRUCTIONS ARE NOT FOLLOWED.

- This service manual should be retained in a safe place for future reference. The installation of your new fryer must conform to current codes, with the current National Electrical Codes and regulations as applicable.
- Your ventilation hood, when installed, must conform to the current standards.
- You must maintain this appliance free and clear from combustibles.
- Adequate clearance for servicing and proper operation must be maintained. Your fryer is designed to be serviced from the front.
- Keating commercial fryers are not intended for household use.
- ALWAYS instruct new employees on proper fryer operation.
- A fryer should be operated ONLY by properly trained personnel.
- ALWAYS turn fryer off each night.
- ALWAYS turn fryer off at customer power panel before servicing.
- NEVER leave a fryer unattended during operation.
- NEVER move a fryer when full of hot oil.
- NEVER introduce objects or liquids into fryer while operational, which are not designed or made for cooking.
- THIS FRYER MAY NOT BE ALTERED, MODIFIED OR CHANGED IN ANY WAY.

This fryer MUST be installed, inspected, calibrated and serviced by qualified and/or certified and/or licensed service personnel - you may void your Keating warranty if installation is not completed per local, national and Keating specifications. Contact your dealer for assistance.

■ FIRST STEPS

POSITIONING

The fryer must be placed under an exhaust hood with a fire retardant system. Your ventilation hood, when installed, must conform to the current standards. ALL connections and placement must comply with current local and national codes. It is the responsibility of the owner and local installer to comply with these regulations when installing the fryer.

Counter model and floor model fryers **must be restrained to prevent tipping** when installed in order to avoid splashing, spilling, etc. of hot liquid. The restraining method may be a manner of installation or by separate means.

Figure 1

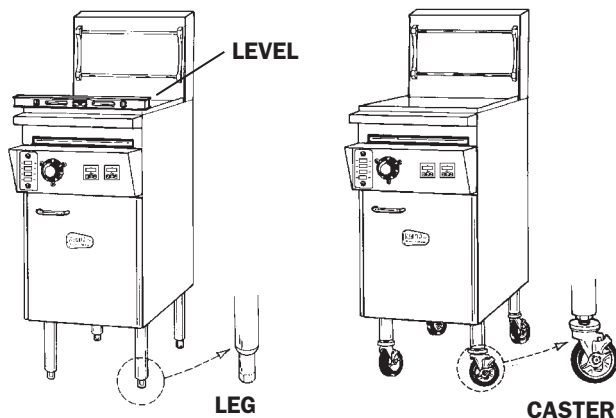

LEVELING

The fryer will operate at its highest efficiency when properly leveled. Place a level on fryer vessel from side to side. For fryers on legs, the bottom foot of the leg is adjustable. Looking from the bottom of the foot, turn clockwise to decrease height or counter clockwise to increase height until level. For fryers on casters, the casters are adjustable by loosening the jam nut and turning the caster in or out. When the desired level is reached, tighten the jam nut. Adjustments of more than 3/4" are not recommended on any caster. The same procedure should be followed to level the fryer from front to back.

RESTRAINING DEVICES

1. Adequate means must be provided to limit the movement of the appliance without depending on the connector and the quick-disconnect device or its associated piping to limit the appliance movement.

Fryer must also be restrained to prevent tipping when installed so that hot liquid splashing is avoided.

▲ NOTICE



2. The restraint means must be attached to the rear of the Keating Electric Fryer within 2" of the center line width and approximately 1-5/8" from the bottom of the cabinet back to allow the restraining bolt to be anchored to the cabinet back between the cabinet bottom and inner liner.

If disconnection of the restraint is necessary, it must be reconnected when the Keating Electric Fryer is returned to its originally installed position.

ELECTRICAL CONNECTION

The Keating Instant Recovery® Electric fryer is equipped with a three wire terminal block for customer connections. The terminal block is located behind the fryer door on the right side behind a panel (held in place by two screws). Compare the fryer terminal connections to the appropriate wiring diagram for the fryer (see pages 21 thru 25) to see if the fryer is connected three phase or single phase. All wires/cords, plugs, receptacles and circuit breakers must be sized adequately for the full load rating of the fryer as specified by local codes, or in the absence of local codes, by the current National and Canadian Electrical Codes as applicable.

The Keating Electric Fryer is also equipped with a grounding lug next to the terminal block. For proper grounding procedures, see local codes or, in the absence of local codes, by the current National and Canadian Electrical Codes as applicable.

NOTE: The connections to the fryer can be changed in the field from three phase to single phase or from single phase to three phase. This can be done by simply changing the wiring at the terminal block. To change the connections for your fryer, see the appropriate wiring diagram for your fryer on pages 21 thru 25.

NOTE: For fryers rated at 208-240 volts, the amperage ratings marked on the nameplates of the fryers are listed at 240 volts as required by UL. If your fryer is to be fed by a 208 or 220 volt system, consult the Keating Fryer Specifications on pages 26 and 27 to determine the full load rating of the fryer.

NOTE: Some fryers with Basket-Lifts, Zero-Space™ Filters (model BB ZS or TS ZS) or Central Filters may have separate 120 volt control circuit connections. Fryers with Basket-Lifts or Zero-Space™ filters will need the connections made to a separate smaller terminal block located near the larger terminal block for the 208-240 volt connections or inside a separate wiring box. This terminal block will have one black and one white wire connected to it. Fryers with Central Filters will need the connections made inside the Central Filter junction box. For proper connections, refer to the appropriate wiring diagram on pages 21 thru 25.

NOTE: A copy of the wiring diagram is included in this manual.

NOTE: A hole has been punched in the rear of the fryer cabinet for a cord or conduit exit. If a cord is used, the National Electrical Code, ETL standards and most local codes require a bushing or strain relief (not provided by Keating) to protect the cord.

WIRE SIZE TABLE

Conductor Current (Amps up to)	Recommended Wire Size (AWG)
15	14*
20	12*
30	10*
40	8
55	6
70	4
95	2
125	0
145	2/0
165	2/0**
190	2/0**

*For runs greater than 75' up to 125', use the next wire size larger to keep the voltage drop to less than 3%. For runs greater than 125', consult the National Electrical Code Handbook to help determine the proper wire size.

**2/0 wire ambient temperature must be kept at less than 104°F (40°C).

OPERATING

FILLING

NOTE: Before filling the fryer make certain the fryer vessel is sanitized, dry and the drain valve is completely closed. Refer to figures 4 and 5 on page 6 for location of drain valve.

WARNING

BE SURE THE HEATING ELEMENTS ARE COMPLETELY COVERED WITH OIL BEFORE SWITCHING THE FRYER ON. IF OIL LEVEL DROPS BELOW TOP OF HEATING ELEMENTS, SEVERE DAMAGE TO FRYER AND INJURY TO OPERATOR MAY RESULT.

CAUTION

WATER IN ANY FORM AND HOT OIL DON'T MIX!

CAUTION

OIL EXPANDS WHEN HEATED. THE FILL LEVEL LINE HAS BEEN PROVIDED TO ENSURE OPTIMUM COOKING WHILE ENSURING THE SAFETY OF THE OPERATOR. DO NOT OVERFILL THE FRYER VESSEL.

Figure 2
Fill Level Line

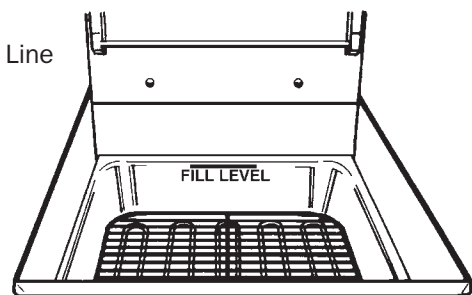

BB & TS, CPU and Basket-Lift Models

1. Fill the fryer vessel with oil up to the "Fill Level" line.
2. If using solid shortening, remove screen and firmly pack solid shortening between the heating elements. Proceed to Melting section for instructions on use of the melt cycle.

MELTING

The Keating Melt Cycle safely melts solid shortening in the fryer vessel without scorching.

WARNING

BEFORE ATTEMPTING TO LIGHT THE FRYER, MAKE SURE THE ELECTRIC CONNECTIONS ARE SECURE AND HAVE BEEN LEAK TESTED AND THE FRYER HAS BEEN PROPERLY FILLED WITH OIL.

A. BB, TS and Basket-Lift Models

1. Set the thermostat to the desired temperature.
2. If using solid shortening, set On/Off/Melt switch to the "MELT" position. Stay in the "MELT" cycle until the shortening has melted completely and is at the "Fill Level" line before switching to the "ON" position for cooking.

B. CPU Models

*See separate computer instructions or call 1-800-KEATING.

NOTE: During the “MELT” cycle, the elements are on for approximately 5-7 seconds and off for approximately 35 seconds.

Figure 3

BB, TS and TS Basket-Lift Control Panels

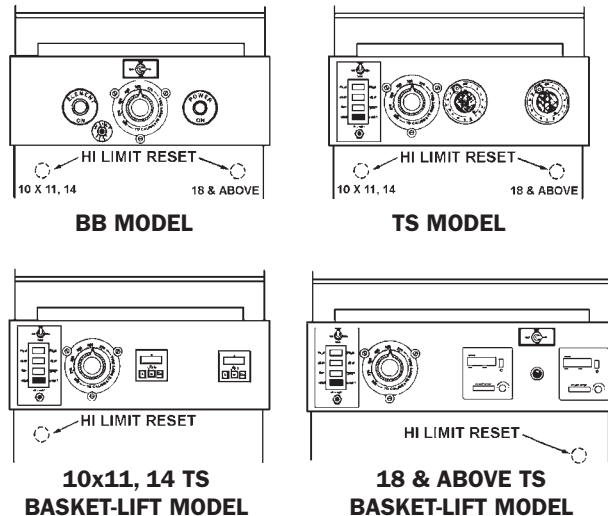
**COOKING**

Keating Instant Recovery® Electric Fryers are designed to provide maximum production efficiency and deliver high quality food products. Low-temperature cooking, highly polished stainless steel and a true COLD ZONE mean extended oil life. Follow cooking procedures for your model.

⚠ WARNING

OPERATION OF THIS FRYER SHOULD BE LIMITED TO PERSONNEL WHO HAVE BEEN THOROUGHLY TRAINED IN OPERATING PROCEDURES.

USE ONLY KEATING APPROVED BASKETS IN YOUR FRYER. NEVER OVERFILL FRY BASKETS. DO NOT BANG BASKETS ON BASKET HANGERS OR FRYER VESSEL.

CARE SHOULD BE TAKEN WHEN LOWERING BASKETS INTO FRYER TO PREVENT SPLASHING HOT OIL FROM FRYER VESSEL.

NEVER LIFT BASKETS DIRECTLY OUT OF THE FRYER VESSEL WITHOUT DRAINING AS SEVERE INJURY MAY RESULT.

NOTE: For safety purposes, all Hi-Limit controls are manually reset. Always check the Hi-Limit reset button before attempting to use the fryer. If the Hi-Limit has tripped, the fryer will not operate.

NOTE: For a fryer with a Central or Safe & Easy® Filter, always check the rear drain operating handle before attempting to use the fryer. A safety switch prevents the fryer from operating if the handle is not pushed in completely and locked into place.

A. BB Models

1. Fill fryer as described on page 4 - FILLING.
2. Set On/Off switch to the “On” position. “ELEMENT ON” light will be illuminated.
3. Set thermostat to the desired frying temperature (between 325°C and 335°C).
4. When the oil reaches the desired frying temperature and the “ELEMENT ON” light goes off, lower filled basket(s) slowly into the hot oil.
5. When cooking cycle is complete, carefully lift basket(s) out of oil. Place them on basket hanger rods (on splashback of fryer) to allow draining of excess oil.

B. TS Model

1. Fill fryer as described on page 4 - FILLING.
2. Set On/Off switch to the “On” position. “HEAT” light will be illuminated.
3. Set thermostat to the desired frying temperature (between 325°C and 335°C).
4. When the oil reaches the desired frying temperature, the “HEAT” light will go off, and the “COOK” light will illuminate.
5. Lower filled basket(s) slowly into the hot oil.
6. Set timer for left or right side basket, whichever is being lowered into oil.
7. When timer sounds, lift basket out of oil. Place on basket hanger rods (on splashback of fryer) to allow draining of excess oil.

C. Basket-Lift Models

1. Fill fryer as described on page 4 - FILLING.
2. Set On/Off switch to the “On” position. “HEAT” light will be illuminated.
3. Set thermostat to the desired frying temperature (between 325°C and 335°C).
4. When the oil reaches the desired frying temperature, the “HEAT” light will go off, and the “COOK” light will illuminate.
5. Fill basket(s) to proper level and place on upper bar of lift rod(s).
6. Set timer(s) to desired cooking time. For programming timers see pages 7-9.
7. Push “START-STOP” button on timer(s). Basket(s) will automatically lower into fryer vessel.

8. When cooking cycle is complete, an audible alarm will sound and the basket(s) will raise automatically. Allow oil to drain before removing baskets. Basket(s) will automatically lower into fryer vessel.

D. CPU Model

*See separate computer instructions or call 1-800-KEATING.

SHUTDOWN

A. BB, TS and Basket-Lift Models

1. Turn fryer On/Off/Melt switch to “OFF” position.

B. CPU Model

1. Set Main Power On/Off switch to the “OFF” position.

DRAINING

⚠WARNING

ALWAYS SHUT THE FRYER OFF COMPLETELY BEFORE DRAINING. THE FRYER SHOULD BE DRAINED ONLY UNDER THE SUPERVISION OF PROPERLY TRAINED PERSONNEL. A DRAIN PIPE AND COVERED CONTAINER SUITABLE FOR USE WITH HOT OIL SHOULD BE USED TO ENSURE THE SAFETY OF THE OPERATOR.

- 1. Operator should be outfitted with proper attire including:
 - Oil and heat resistant gloves
 - Oil and heat resistant apron
 - Safety goggles
 - Oil and heat resistant footwear

Figure 4
Operator in Safety Gear

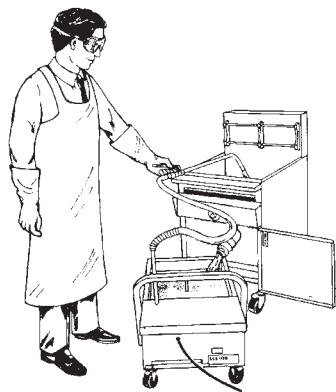

- 2. Turn off the fryer and open the door.
- 3. For front drain fryers, put approved container under drain valve. For fryers with a central filter, slide filter drawer in completely.

4. For front drain fryers, slowly turn handle forward to avoid splashing. The drain valve will be completely open after 1/4 turn.

5. For units with rear drain valves, slowly pull drain valve operating handle straight out (unhook from metal latch first). See Safe & Easy operator’s manual for instructions on how to filter.

Figure 4
Front Drain Valve

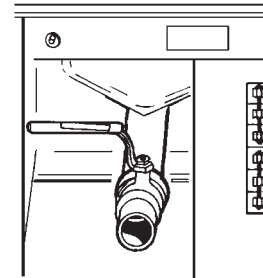
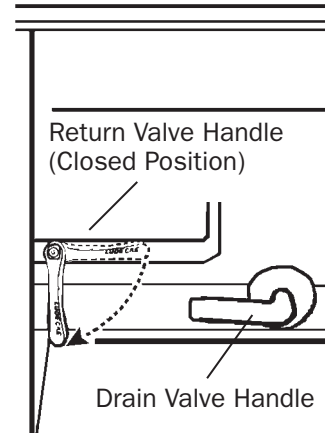

Figure 5
Rear Drain Valve



⚠WARNING

UNDER NO CIRCUMSTANCES SHOULD YOU PERMIT HOT OIL TO COME IN CONTACT WITH WATER OR ICE. ALL DRAINING SHOULD BE DONE UNDER THE SUPERVISION OF PROPERLY TRAINED PERSONNEL. A DRAIN PIPE AND COVERED CONTAINER SUITABLE FOR USE WITH HOT OIL SHOULD BE USED WHENEVER A FRYER IS DRAINED. ALWAYS DRAIN OIL INTO A COVERED RECEPTACLE APPROVED FOR THE TRANSPORTATION OF HOT OIL.

CLEANING AND BOIL OUT

When cleaning and boiling out your fryer use Keating Sea Powder and Keating Klenzer to keep your fryer in top condition. Keating Sea Powder dissolves any grease build up - even carbonized grease in fryer vessels - one of the leading causes of premature oil breakdown. And once your fryer vessel is clean, use Keating Klenzer, the finest dry stainless steel polish available, to restore your Keating Instant Recovery® Electric fryers’ exterior to its original luster.

Figure 6
Keating Klenzer
and Sea Powder



CAUTION

To avoid damaging the fryer, do not power wash, spray or hose down unit while cleaning.

1. Put on safety attire. See page 6 - DRAINING.
2. Turn the fryer off.
3. Drain oil from fryer, see page 6. Filtering may be done at this step.
4. Remove oil container to a secure area to prevent accidental spillage.
5. Fill fryer vessel to "Fill Level" line with water.

WARNING

UNDER NO CIRCUMSTANCES SHOULD THE FRYER BE LEFT UNATTENDED DURING BOIL-OUT. TRAINED PERSONNEL MUST BE PRESENT DURING THE PROCEDURE TO PREVENT BOIL OVER OR TO TURN OFF THE POWER IF WATER DROPS BELOW HEATING ELEMENTS.

6. Set thermostat and turn fryer on to bring water to a gentle boil.
7. Once boil has been reached, turn fryer off.
8. Dissolve 2/3 cup of Keating Sea Powder for every five gallons of water and let soak for 1/2 hour. If there is a large build-up of carbonized grease, allow fryer to soak overnight.

CAUTION

DO NOT DAMAGE OR REMOVE THERMOSTAT BULB AS THIS MAY AFFECT THE ACCURACY OF THE FRYER.

9. While soaking, a natural fiber brush may be used to scrub the inside walls of fryer.
10. Drain the water and Sea Powder into a dry, suitable receptacle and remove from cooking area.
11. Spread Keating Klenzer liberally on sides of fryer vessel.
12. At this point, a non-abrasive scouring pad may be used to remove the now softened carbonized grease.
13. Thoroughly rinse fryer vessel with potable water to remove all Klenzer.

14. Prior to refilling with oil, wipe the inside of the fryer vessel making sure all water and Klenzer has been removed.

CAUTION

WATER IN ANY FORM AND HOT OIL DON'T MIX!

15. Close drain valve.

WARNING

FAILURE TO CLOSE DRAIN VALVE BEFORE REFILLING THE FRYER MAY RESULT IN SERIOUS INJURY.

WARNING

WHEN YOUR FRYER IS BEING USED IN CONJUNCTION WITH A CENTRAL FILTER, DISCONNECT POWER SUPPLY BEFORE RESETTING MOTOR TO PREVENT SERIOUS INJURY WHEN RESET SWITCH IS ENGAGED (SEE FILTER MANUAL).

16. Check thermostat bulb positioning - see page 10.
17. Refill the fryer with new or filtered oil.

NOTE: MSDS Sheets for Keating Klenzer, Sea Powder & Acidox are available on-line at www.keatingofchicago.com.

ELECTRONIC CONTROL TIMERS

The electronic timers provide a clearly visible and accurate display and are very easy to use.

10x11 & 14 TS MODELS

A. Electronic Timer

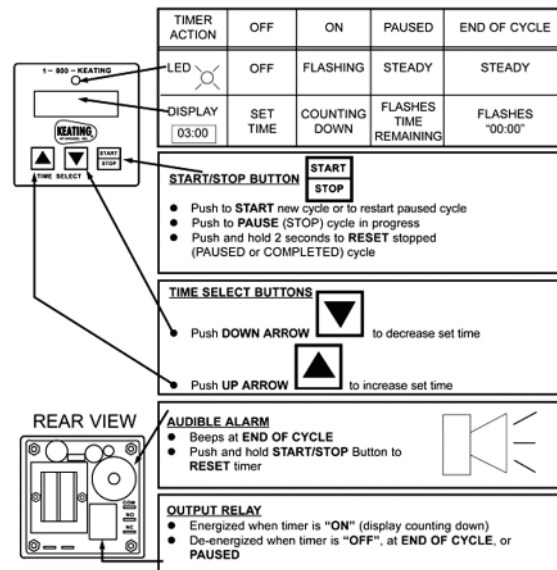

B. Electronic Timer Programming

Figure 7
Electric Timer

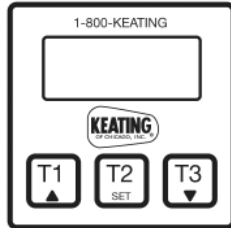

- The Keating Electronic Timer is programmable to four different timer ranges with two different alarm modes for each time range.

- The timers are shipped from the factory preset to program 5: Minutes : seconds (00:01 to 59:59) with continuous alarm.

- To program another time range or alarm mode perform the following steps:

1. Turn off the power.
2. Press the “down arrow“ button while turning the power on.
3. Release the button after the display turns on.
4. A number from 0 to 7 will appear.

This number corresponds to:

0 = Seconds (000.1 to 999.9) 5 second alarm

1 = Minutes : Seconds (00:01 to 59:59)
5 second alarm

2 = Seconds (0001 to 9999) 5 second alarm

3 = Hours : Minutes (00:01 to 23:59)
5 second alarm

4 = Seconds (000.1 to 999.9) continuous alarm

5 = Minutes : Seconds (00:01 to 59:59)
continuous alarm

6 = Seconds (0001 to 9999) continuous alarm

7 = Hours : Minutes (00:01 to 23:59)
continuous alarm

5. Use the “down arrow” button to select the desired time range.
6. Turn off the power.
7. Wait 2 seconds.
8. Turn on the power. (the timer will remain in the new time range until programmed).
The electronic timers, used on 18" and above Basket-Lift models, provide a clearly visible and accurate display and are very easy to use. One knob sets the time and one button controls all operations. The display can show cooking or clock time.

18 - 34x24 TS MODELS

A. Timer Mode

1. Turn round knob clockwise (toward “+”) to increase time or counterclockwise (toward “-”) to decrease time.

NOTE: When programming the timer up to one minute, the display goes up or down in seconds only. After one minute, the display goes up or down in ten minute increments.

2. Push start/stop button to start timer.
3. When buzzer sounds, push start/stop button to shut off buzzer. Display will go blank.
4. Push start/stop button again to restore cycle time to display.
5. To clear display, turn round knob fully counterclockwise (toward “-”).

B. Clock Mode

1. To set time, hold clock (“⌚”) button in and turn knob clockwise (toward “+”) to increase time or counterclockwise (toward “-”) to decrease time.
2. To display timer cycle time, push start/stop button.
3. If display is blank, pushing the clock button will restore clock time to display.

C. To determine whether timer is in timer mode or clock mode

1. Timer mode - display will show decimal point in upper position (“10.08”).
2. Clock mode - display will show a decimal point in lower position (“10.08”).

OPTIONAL TIMER OPERATING INSTRUCTIONS Part # 056921

Figure 7
Electric Timer

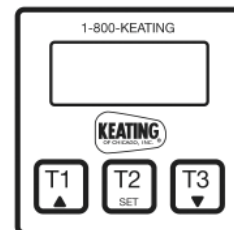

DIGITAL TIMERS

The electronic timers, standard on TS models, provide a clearly visible and accurate display and are very easy to use.

PROGRAMMING

To program the timers, the unit must be in the idle mode. Press and hold the set button for approximately two seconds. The display will show "SEt". Press the button for the channel to be programmed. The display will show the current setting for that channel. Use the up or down button to increment or decrement the setting. When the setting is correct, press and hold the set button again for approximately two seconds. The display will show "StO" for approximately two seconds and the timer will return to normal operation. Repeat the process as necessary for the other timers.

OPERATING LOGIC

When the timer is powered up, the display will show the time setting for the channel that was operated last and the relay output contacts will be open. To start a cycle, press the desired channel button (1-3). The display will begin to countdown from the pre-set time setting and the relay output contacts will close. During the countdown the colon will flash at a one-second rate. When the countdown has reached "00:00" the relay output contacts will open, the display will flash, and the audible alarm will sound. To cancel the audible alarm, press any button.

PAUSE FEATURE

To pause a cycle in progress, press any button. The relay output contacts will open, the display will flash, and the countdown will pause. To resume the countdown, press any button. The display will resume the normal countdown and the relay output contacts will close.

CANCELING A CYCLE

To cancel a cycle in progress press and hold any button for approximately two seconds. The relay output contacts will open and the display will show the time setting for the channel last used.

■ MAINTENANCE

WARRANTY REPAIRS

Keating's warranty begins with the date of installation. In the event that your fryer, under warranty, needs repairs other than routine maintenance or cleaning, you are required to contact Keating of Chicago (at 1-800-KEATING) before calling a local service company.

PREVENTIVE MAINTENANCE

Preventive maintenance should be done in daily, weekly, monthly and yearly intervals as necessary. Following preventive maintenance procedures will help keep your fryer working efficiently. Proper care and servicing will lead to years of quality performance.

TIME FRAME	OPERATOR/OWNER
AT LEAST DAILY*	<ul style="list-style-type: none"> • Check lights and controls. • Check that the oil is up to "Fill Level" Line. • Clean all baskets. • Drain, strain or filter oil.
AT LEAST WEEKLY*	<ul style="list-style-type: none"> • Drain and clean fryer. • Boil-out fryer.
AT LEAST MONTHLY*	<ul style="list-style-type: none"> • Verify Thermostat settings. • Test Hi-Limit control. • Verify wire connections. • Disassemble fryer to clean burners, orifices and runner pilot tube.
TIME FRAME	QUALIFIED SERVICE PERSONNEL
AT LEAST YEARLY*	<ul style="list-style-type: none"> • Calibrate thermostat.

*High production facilities should be checked more often. Contact the factory or a local service company to perform maintenance and repairs.

Oil Breakdown

As part of a "Preventive Maintenance Program", the oil in your fryer needs to be filtered regularly to avoid breakdown. The initial investment in the frying system is less than the total overall costs of oil during the life of the fryer, and with regular filtering, you can realize substantial savings in oil costs as well as maintenance charges.

1. *Contact with Oxygen:* When air comes into contact with hot oil, the oxygen begins to dissolve in the oil causing it to breakdown. Cooler oil, on the other hand, deters breakdown. The Keating Instant Recovery® Electric fryer is designed to allow you to cook at lower temperatures to help reduce the rate of oil breakdown. Be sure to keep your oil covered when not in use.

2. *Crumbs and Food Particles:* As food is prepared in a fryer, particles and crumbs will fall off into the oil. If these particles are not removed, they will begin to carbonize and cause premature breakdown. The Keating true Cold Zone captures these particles and prevents them from carbonizing.

3. *Non-Stainless Steel Surfaces:* When hot oil comes in contact with iron, steel, aluminum or other metals, a chemical breakdown takes place within the oil. Stainless steel has long been recognized as being the best metal for use in the construction of fryer vessels. That is why all Keating fryer vessels and heating elements are made of stainless steel that is highly polished to a #7 mirror bright finish.

4. *Keep Salt and Seasonings Away From Oil:* When sodium or sodium by-products are added or splashed into hot oil, the oil will take on an inky blackness and form a brownish deposit around the top of the fryer rendering the oil useless within a few days. Fresh potatoes may be treated with sodium sulfite to retain whiteness, always thoroughly wash the potatoes before frying.

5. *Prolonged High Temperatures:* When a fryer is set on a high temperature for long hours and a low volume of frying is done, the oil will breakdown from the intense heat. For every 18°F above 300°F the rate of oil breakdown doubles. The Keating BB and TS model fryers can easily be switched off with a control panel switch. The temperature at which the food is placed in the fryer is far less important than the temperature at which the food is finished. The fryer will heat back up to the thermostat setting well before the food is finished frying.

LIMITED CALIBRATION

(Less than 15° difference)

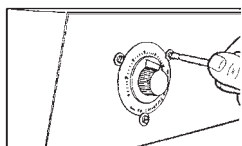

You will need: One standard flat blade screwdriver
One accurate fryer thermometer

1. Set thermostat to desired frying temperature.
2. Allow fryer to cycle three times.
3. Place an accurate thermometer in the oil.
4. If calibration of fryer is less than 15° off, simply loosen three dial plate retaining screws, rotate dial plate to match thermometer reading and tighten screws. For calibration over a 15°F difference, contact your local service distributor.

⚠ WARNING

DO NOT ADJUST THE THERMOSTAT SET SCREW - IT VOIDS ANY WARRANTY ON PART.

NOTE: Locate thermometer in same position for every calibration. Position next to upper heating element is recommended.

Thermostat Bulb Positioning

Keating's patented thermostat application is accurate within $\pm 2^{\circ}\text{F}$ of the dial setting between 250°F and 350°F. This accuracy is attained only if the thermostat bulb is placed properly against the top element using element clamps. If the bulb is too far away from the element, the fryer will overshoot.

Overshoot: The thermostat takes a long time to cycle and then misses its preset temperature by 20°F - 40°F yielding a poor quality product.

Hi-Limit Check

The manual Hi-Limit test button can be used to test the Hi-Limit Control by pushing and holding the button in until the fryer reaches the Hi-Limit temperature (425°F). Place an accurate thermometer in the oil. If the Hi-Limit Control doesn't shut off the fryer between 425°F and 450°F, have it replaced.

■ SERVICE DIAGNOSIS

The following diagnosis is only to be used as a guide to qualified service personnel. Keating recommends that you use a qualified & licensed service company. (Equipment still under warranty requires it.) Call 1-800-KEATING if you need assistance in locating a qualified service company.

A properly adjusted Keating Instant Recovery® Electric Fryer, with no load, will cycle “on” approximately every 2 1/2 to 3 minutes. Each cycle will last 15-25 seconds, ensuring that the temperature setting is held within a narrow band.

NOTE: To correctly and quickly diagnose the system, the chart below should be followed in sequential order.

TROUBLE SHOOTING CHART

PROBLEM	PROBABLE CAUSE	SOLUTION
Fryer won't heat	<ul style="list-style-type: none"> a. No electricity to fryer (“POWER ON” light is off). b. No electricity to control circuit (models with Basket-Lift or Central Filter). c. Fryer circuit breakers have tripped. d. Hi-Limit has been activated. e. Rear drain valve handle has not been fully closed (fryers with filter only). f. Control circuit fuse is blown. g. ON/OFF/MELT switch is faulty. h. Contactor is faulty. i. Thermostat is faulty. 	<ul style="list-style-type: none"> a. Connect fryer to an approved source of power. b. Connect 120V terminal block to an approved source of power. c. Reset circuit breakers. d. Push in Hi-Limit Reset button located behind fryer door. Check calibration of thermostat and operation of Hi-Limit and contactor. e. Fully close and latch rear drain valve handle. f. Replace fuse. (Use type SC-5 for 10x11 and 14TS BL models and type SC-3 for all other models.) g. Replace ON/OFF/MELT switch. h. Replace contactor. i. Push and hold in Hi-Limit test button. If elements turn on, thermostat is faulty. Replace thermostat
Fryer has poor recovery or runs cold	<ul style="list-style-type: none"> a. Over-filling baskets. b. Fryer vessel overfilled with oil. c. Thermostat out of calibration. d. Carbon coating on elements. e. Element is faulty. f. Thermostat is faulty. g. Contactor is faulty. 	<ul style="list-style-type: none"> a. Don't overfill baskets. b. Fill fryer up to “Fill Level” line as oil expands when heated. c. Calibrate thermostat. (See Calibration). d. Boil-out fryer. (See Cleaning and Boil-Out). e. Replace Element. f. Replace thermostat. g. Replace contactor.
Fryer is overheating	<ul style="list-style-type: none"> a. Thermostat bulb improperly placed. b. Thermostat out of calibration. 	<ul style="list-style-type: none"> a. Adjust bulb position. (See Thermostat Bulb Positioning). b. Calibrate thermostat (See Calibration).
Oil in fryer vessel smokes	<ul style="list-style-type: none"> a. Oil has begun to break down. b. High carbon content in oil. c. Dirty fryer vessel. d. Inferior grade of oil. e. Fryer is overheating. 	<ul style="list-style-type: none"> a. Replace oil. b. Filter oil completely, replace if necessary. c. Boil-out fryer. See Cleaning and Boil-Out. d. Check with oil supplier for higher grade of oil needed for your cooking applications. e. Check calibration of thermostat (See Calibration) and replace if necessary. Check if Hi-Limit trips at 425°F. If not, replace Hi-Limit.

PROBLEM	PROBABLE CAUSE	SOLUTION
Oil in fryer vessel boils over	<ul style="list-style-type: none"> a. Baskets are overfilled. b. Fryer vessel overfilled with oil. c. Oil is breaking down and foaming. d. Water in cold zone. 	<ul style="list-style-type: none"> a. Don't overfill baskets. b. Fill fryer up to "Fill Level" line as oil expands when heated. c. Replace oil. d. Stir oil with a paddle until water boils off. Filter oil. If water remains, let oil cool and drain a quart of it.
Contactors chatters	<ul style="list-style-type: none"> a. Voltage is low to fryer. b. Contactor coil faulty. c. Connections are loose. d. Thermostat contacts do not close properly. 	<ul style="list-style-type: none"> a. Contact your electrician or the local power company and have the incoming power checked. b. Replace contactor. c. Tighten connections. d. Replace thermostat.
Basket-Lift mechanism will not operate	<ul style="list-style-type: none"> a. Connections are loose or timer is faulty. b. Motor limit switch is faulty. c. Lift motor is faulty (10x11 and 14 TS BL models). d. Actuator is faulty (18 TS BL Model and above). e. Control circuit fuse has blown. f. Relay is faulty (18 TS BL Model and above). 	<ul style="list-style-type: none"> a. Tighten connections. Replace timer if it will not operate. b. Replace Motor limit switch (10x11 and 14 TS BL). Replace actuator (18 TS BL Model and above.) c. Replace motor. Specify left or right side motor when ordering. d. Replace fuse (use type SC-5 in 10x11 BL Models and type SC-3 in 18 TS Model and above). e. Replace relay.
Basket-Lift motor runs, but basket doesn't move	<ul style="list-style-type: none"> a. Cam is slipping on motor shaft faulty. (10x11 and 14 TS BL models). 	<ul style="list-style-type: none"> a. Tighten cam onto motor shaft.
Basket-Lift basket goes down but won't go up	<ul style="list-style-type: none"> a. Basket-Lift motor limit switch is misaligned (10x11 and 15 TS BL Models). 	<ul style="list-style-type: none"> a. Align limit switch.
Basket-Lift buzzer won't shut off.	<ul style="list-style-type: none"> a. Buzzer limit switch is misaligned (10x11 and 14 TS BL models). 	<ul style="list-style-type: none"> a. Align limit switch.

■ ORDERING PARTS

Parts may be ordered by calling 1-800-KEATING or your local Keating service company. We recommend using genuine Keating Replacement Parts - engineered and manufactured specifically to meet exact specifications and requirements for Keating equipment.

Refer to the Keating Electric Fryer Limited Warranty for complete service and ordering information.

The model/serial plate is attached to the inside of the front door. The serial and model numbers are necessary when ordering.

NOTE: On Drop-In fryers, the model/serial plate is attached to the top of the control panel.

WARNING AND OPERATING PLATES

All warning and operating plates on the Instant Recovery® Electric Fryer should be in place at all times. If plates are damaged or lost, replace them immediately.

■ PARTS LIST - ELECTRIC FRYER

ITEM	DESCRIPTION	MODEL	P/N 220V ELEMENT	Quantity Per Model						
				10x11	14	18	20	24	34x24	
1	HEATING ELEMENT									
	2500 W	BB	004347	3						
	3800 W	TS	005623	3						
	4350 W	BB	004349		3					
	6000 W	BB	004353			3	3			
		TS	004353			4	4			
		BB	004355					4	5	
		TS	004355					5	6	
	6500 W	TS	014493		3					
	TEFLON RING	BB, TS	004318							2 Per Element
	5/8" FLAT WASHER	BB, TS	004319							2 Per Element
	5/8" - 16 BRASS LOCKNUT	BB, TS	004323							2 Per Element
	LOCKWSHR, INT #10 H-TEMP	BB, TS	011562							4 Per Element
	RING TERM #10 HI-TEMP	BB, TS	011881							2 Per Element
	FLAT WASHER #10 HI-TEMP	BB, TS	059502							2 Per Element
	NUT 10-32	BB, TS	000361							2 Per Element
2	CONTACTOR	3P, 32A, 220V COIL	BB, TS	010218	2					
		3P, 50A, 220V COIL	BB	011184		2	2	2		4
		3P, 50A, 220V COIL	TS	011184		2				4
		4P, 40A, 220V COIL	BB, TS, CPU	004330			2	2	2	
		3P, 32A, 120V COIL	BASKET-LIFT	010218	2					
		3P, 50A, 120V COIL	BASKET-LIFT	011225		2			4	4
		4P, 40A, 120V COIL	BASKET-LIFT	005597			2	2		
3	FUSE, 3A, SC-3	TS	004334	2	2	2	2	2	2	2
		BASKET-LIFT*			2	4	4	4	4	4
	FUSE, 5A, SC-5	BASKET-LIFT	008360		2					
4	FUSE HOLDER	TS	004335	2	2	2	2	2	2	2
		BASKET-LIFT*			2	4	4	4	4	4
5	TERMINAL BLOCK, 208V-480V		034381		1	1	1	1	1	1
6	TERMINAL BLOCK		002565	3	1					
7	CIRCUIT BREAKER, 208V-240V									
	1P, 40A		012129							CALL 1-800-KEATING
	2P, 40A		015203							CALL 1-800-KEATING
	3P, 40A		015204							CALL 1-800-KEATING
8	CONTACTOR TRAY	ALL	----	1	1	1	1	1	1	1
9	ELEMENT CLAMP	ALL	004167	2	2	2	2	2	2	2
10	ELEMENT SPACER	ALL	004145			4	4			
11	CONTACTOR SHIELD	ALL	----	1	1	1	1	1	1	1
12	PANEL BAR	ALL	----	1	1	1	1	1	1	1
13	FRYER VESSEL	CALL 1-800-KEATING		1	1	1	1	1	1	1
14	DRAIN VALVE, FRONT, 1"	BB, TS	004553	1	1					
	DRAIN VALVE, REAR, 1"	BB, TS	016341	1	1					
	DRAIN VALVE, FRONT, 1 1/4"	BB, TS	004554			1	1	1	1	2
	DRAIN VALVE, REAR, 1 1/4"	BB, TS	016342			1	1	1	1	2
	DRAIN VALVE, FRONT, 2"	OPTIONAL	019722			1	1	1	1	2
15	DOOR CATCH, ROLLER STYLE	BB, TS	004540	1	1	1	1	1	1	2
16	DRIP CUP (INSIDE DOOR)	BB, TS**	004552	1	1	1	1	1	1	2
17	HI-LIMIT CONTROL W/RESET	BB, TS	004341	1	1	1	1	1	1	1
18	THERMOSTAT	SEE MODEL								SEE PAGES 15-18
19	BASKET HANGER MOUNTING BLOCK									
	LEFT	BB, TS	004539	1	1	1	1	1	1	1
	CENTER	BB, TS	003813			1	1	1	1	2
	RIGHT	BB, TS	004538	1	1	1	1	1	1	1

*18" - 24" BASKET-LIFT MODELS INCLUDE 2 IN TRANSFORMER BOX.

**DRIP CUP NOT ON CM

ITEM	DESCRIPTION	MODEL	10x11	14	18	20	24
20	BASKET HANGER ROD (2 PER FRYER)	BB, TS	018553	018477	018556	018559	018562

ELECTRIC FRYER ASSEMBLY

(Part numbers correspond to list on page 13)

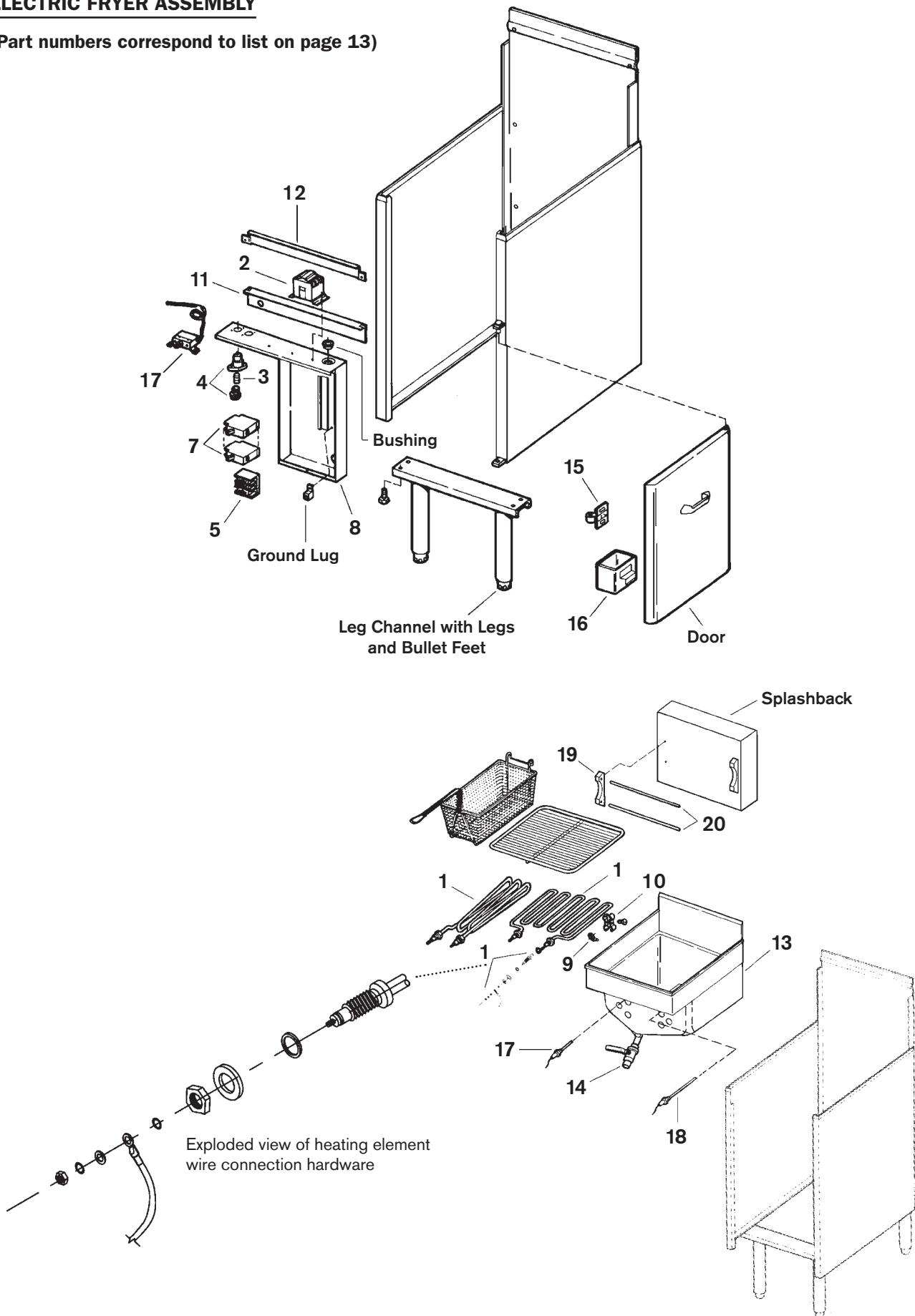

BB CONTROL PANEL

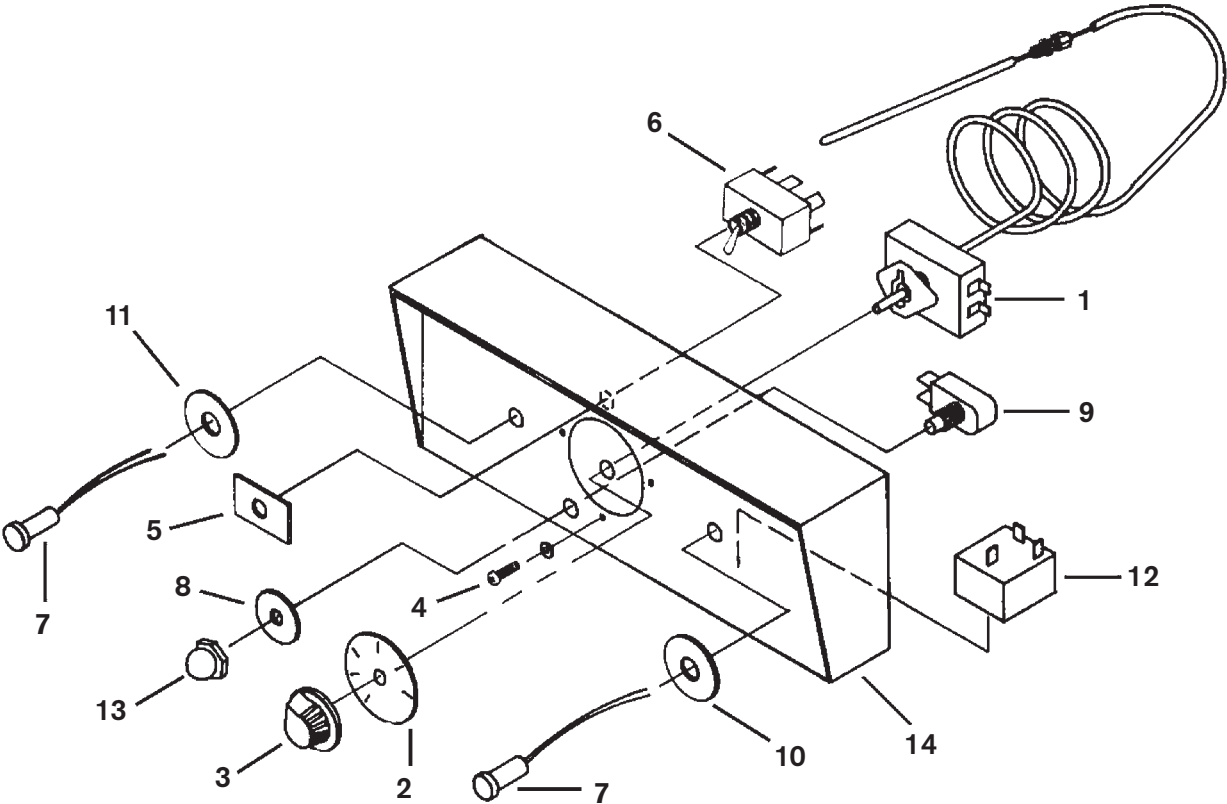

ITEM	DESCRIPTION	P/N	QTY
1	THERMOSTAT	031099	1
2	THERMOSTAT DIAL PLATE	058037	1
3	THERMOSTAT KNOB, BLACK	060612	1
4	RETAINING SCREWS	004610	3
5	ON/OFF/MELT SWITCH PLATE	009919	1
6	TOGGLE SWITCH, ON/OFF/MELT	004326	1
7	INDICATING LIGHT - AMBER 220V	004157	2
8	HI-LIMIT TEST PLATE	004305	1
9	HI-LIMIT TEST BUTTON	004304	1
10	POWER ON LIGHT PLATE	004307	1
11	ELEMENT ON LIGHT PLATE	004306	1
12	MELT CONTROL, 220V	034271	1
13	NUT WITH BOOT	009389	1
14	CONTROL PANEL, HOODED	----	1

TS CONTROL PANEL

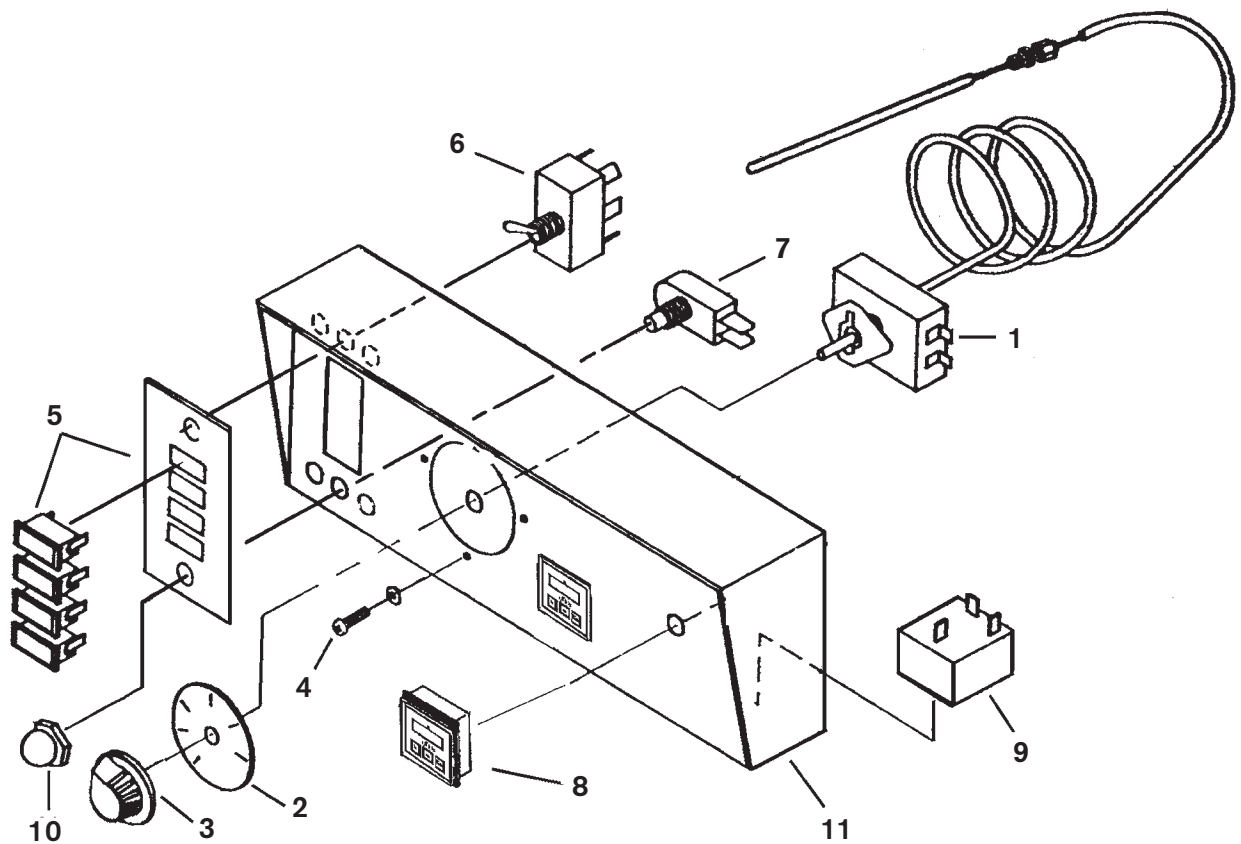

ITEM	DESCRIPTION	P/N	QTY
1	THERMOSTAT	031099	1
2	THERMOSTAT DIAL PLATE	058037	1
3	THERMOSTAT KNOB, BLACK	060612	1
4	RETAINING SCREWS	004610	3
5	LIGHTS, WHITE	016639	3
	LIGHT, RED	016640	1
	MOUNTING PLATE	----	1
6	TOGGLE SWITCH, ON/OFF/MELT	004326	1
7	HI-LIMIT TEST BUTTON	004304	1
8	TIMER	023709	2
9	MELT CONTROL, 220V	037890	1
10	NUT WITH BOOT	009389	1
11	CONTROL PANEL, HOODED	----	1

10x11 & 14 BASKET-LIFT CONTROL PANEL

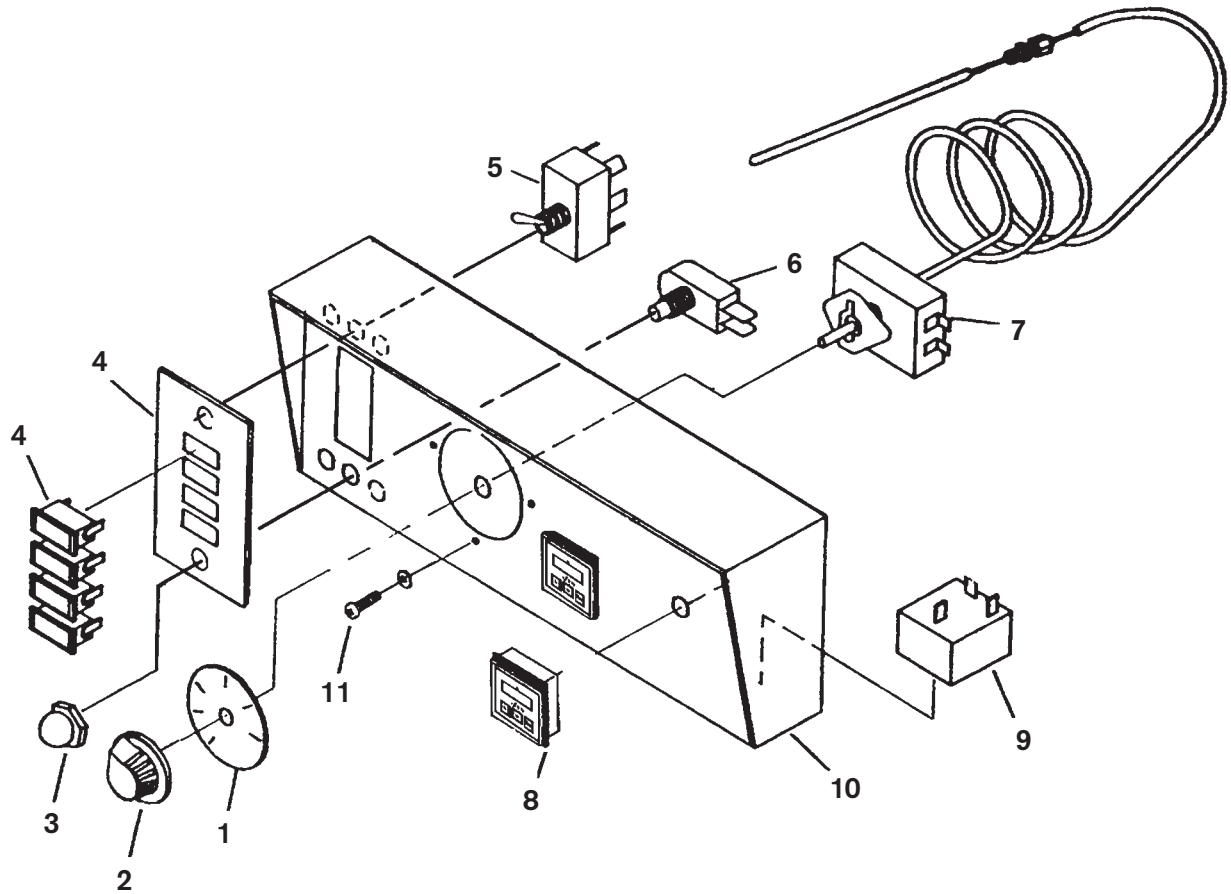

ITEM	DESCRIPTION	P/N	QTY
1	THERMOSTAT	031099	1
2	THERMOSTAT DIAL PLATE	058037	1
3	THERMOSTAT KNOB, BLACK	060612	1
4	RETAINING SCREWS	004610	3
5	LIGHTS, WHITE	016639	3
	LIGHT, RED	016640	1
	MOUNTING PLATE	----	1
6	TOGGLE SWITCH, ON/OFF/MELT	004326	1
7	HI-LIMIT TEST BUTTON	004304	1
8	TIMER	023709	2
9	MELT CONTROL, 120V	004169	1
10	NUT WITH BOOT	009389	1
11	CONTROL PANEL, HOODED	----	1

18 & 34x24 BASKET-LIFT CONTROL PANEL

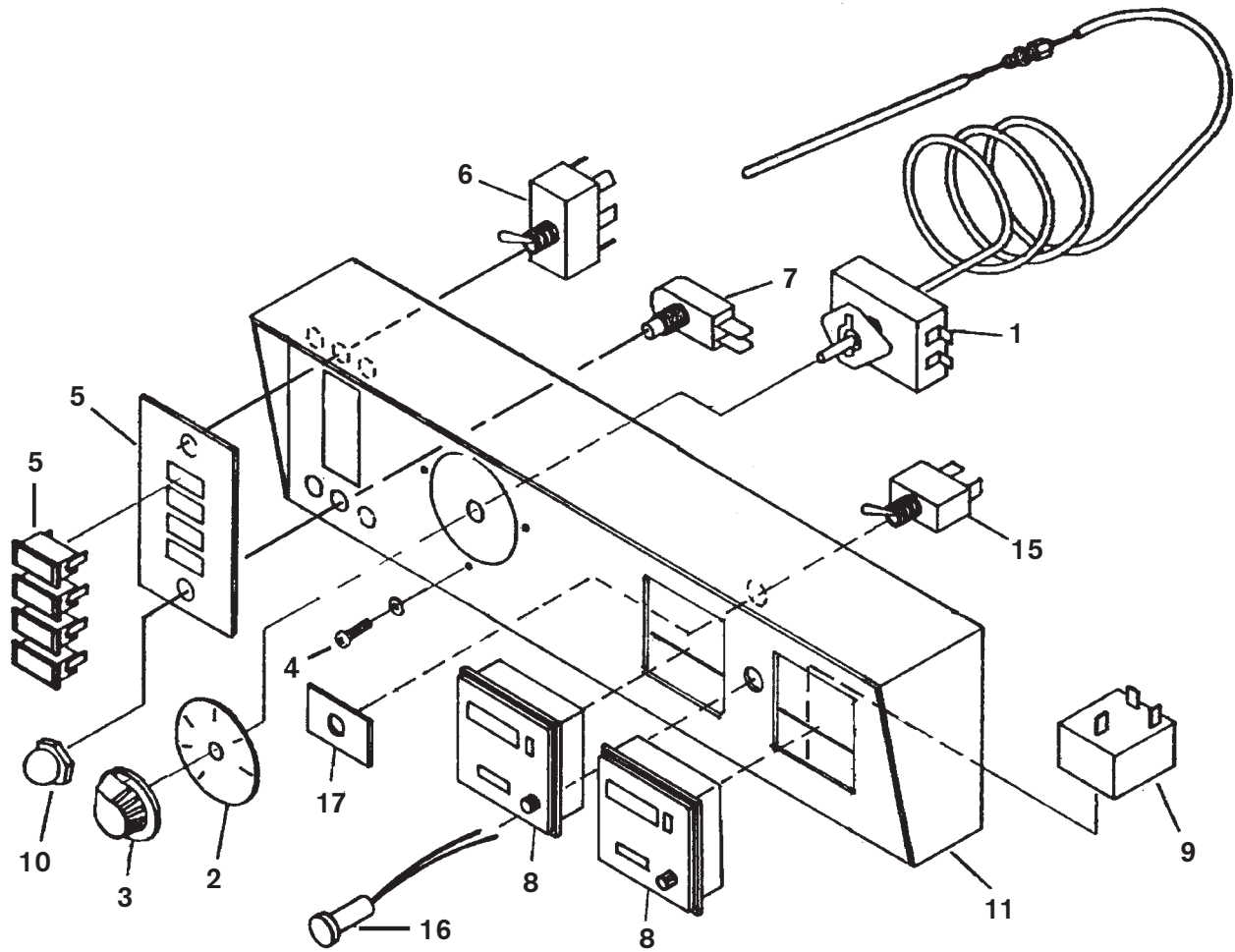

ITEM	DESCRIPTION	P/N	QTY
1	THERMOSTAT	031099	1
2	THERMOSTAT DIAL PLATE	058037	1
3	THERMOSTAT KNOB, BLACK	060612	1
4	RETAINING SCREWS	004610	3
5	LIGHTS, WHITE	016639	3
	LIGHT, RED	016640	1
	MOUNTING PLATE	----	1
6	TOGGLE SWITCH, ON/OFF/MELT	004326	1
7	HI-LIMIT TEST BUTTON	004304	1
8	TIMER	023709	2
9	MELT CONTROL, 220V	037890	1
10	NUT WITH BOOT	009389	1
11	CONTROL PANEL, HOODED	----	1

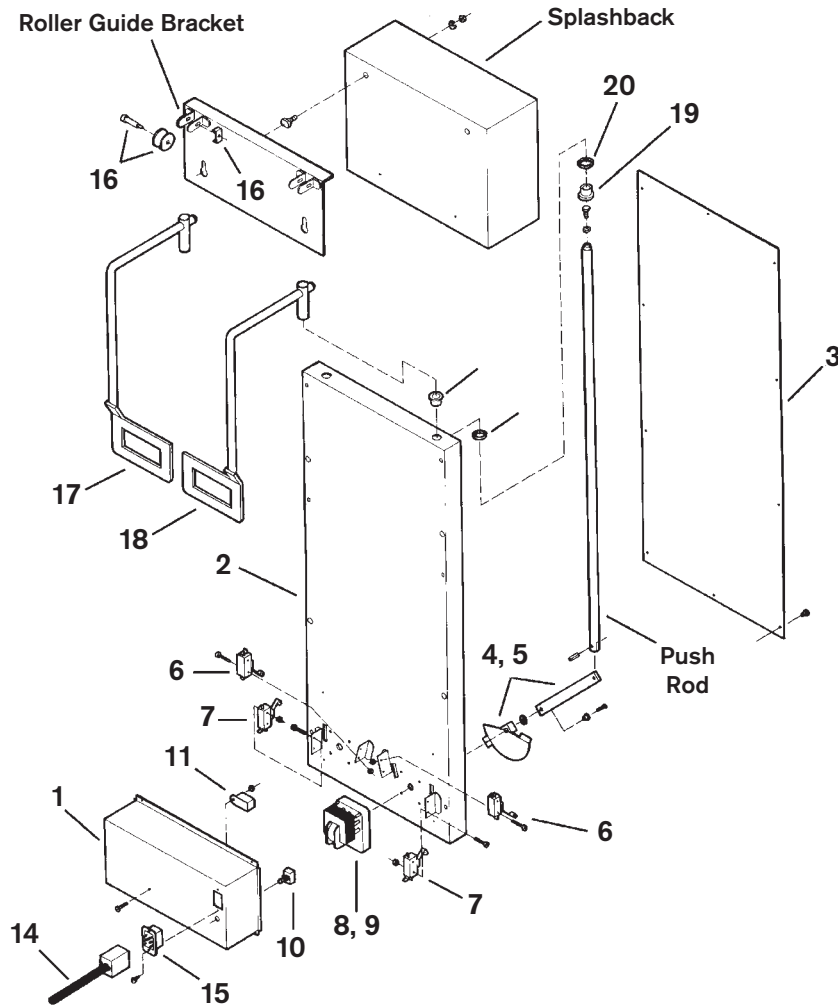
14 BASKET LIFT HOUSING AND ROLLER GUIDE

ITEM	DESCRIPTION	P/N	QTY
1	MOTOR AND WIRE COVER	----	1
2	HOUSING, S/S OR CRS	----	1
3	REAR COVER, S/S OR CRS	----	1
4	LEFT SIDE CRANK BAR & CAM (Viewing front of fryer)	016209	1
5	RIGHT SIDE CRANK BAR & CAM (Viewing front of fryer)	016401	1
6	MICROSWITCH, MOTOR LIMIT	004592	2
7	MICROSWITCH, BUZZER LIMIT	004592	2
8	MOTOR, CCW, LEFT (Viewing front of fryer)	000390	1
9	MOTOR, CW, RIGHT (Viewing front of fryer)	000391	1
10	BUZZER ON/OFF SWITCH WITH PLATE	004499	1
11	BUZZER	004223	1
12	FUSE HOLDER	SEE PAGE 13	2
13	FUSE, GROUND FAULT, 5A, SC-5	SEE PAGE 13	2
14	WIRE HARNESS ASSEMBLY W/PLUG, 6-PRONG	008296	1
15	RECEPTACLE, 6-PRONG, MALE, W/WIRE HARNESS	018754	1
16	ROLLER FOR LIFT ROD	015817	2
	ROLLER PIN	016393	2
	ROLLER PIN LOCK	016392	2
17	LIFT ROD, LEFT (Viewing front of fryer)	018990	1
18	LIFT ROD, RIGHT (Viewing front of fryer)	018991	1
19	BUSHING, PUSH ROD	016405	4
20	BUSHING RETAINING RING	015831	4

18 - 34x24 BASKET-LIFT HOUSING, ROLLER GUIDE and TRANSFORMER BOX

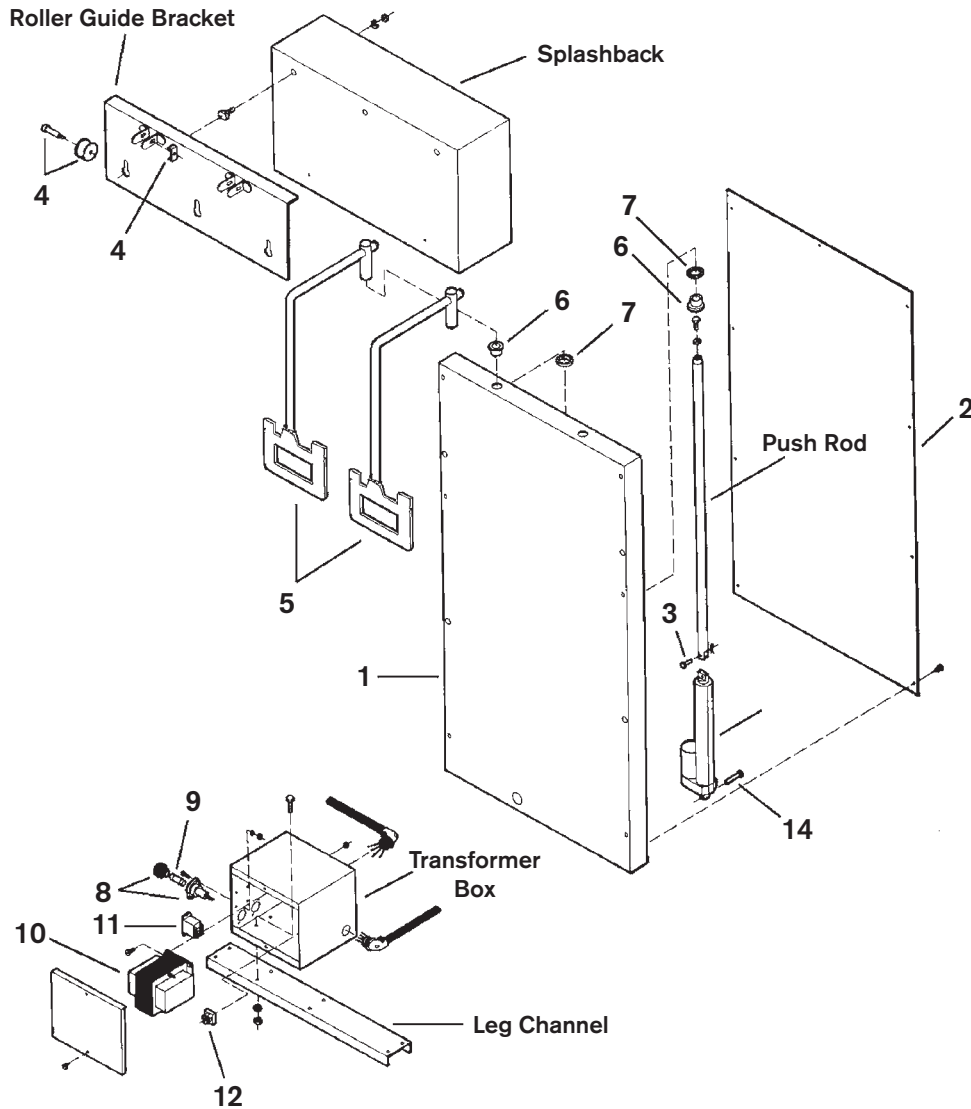

ITEM	DESCRIPTION	P/N	QTY
1	HOUSING, S/S OR CRS	----	1
2	REAR COVER, S/S OR CRS	----	1
3	LINEAR ACTUATOR, 24VDC, WITH LIMIT SWITCHES	018471	2
4	ROLLER FOR LIFT ROD ROLLER PIN)	015817	2
	ROLLER PIN LOCK	016393	2
		016392	2
5	LIFT ROD, FOR SPLIT BASKETS	020086	2
6	BUSHING, PUSH ROD	016405	4
7	BUSHING RETAINING RING	015831	4
8	FUSE HOLDER	004335	2
9	FUSE, ACTUATOR GROUND FAULT, 3A, SC-3	004334	2
10	TRANSFORMER STEPDOWN 120V-24V 150VA (for basket lift with 2 actuators)	011777	1
	TRANSFORMER STEPDOWN 240/480-24V 150VA (for basket lift with 2 Actuators)	019345	1
11	RELAY, BASKET-LIFT	008088	2
12	RECTIFIER, 24VDC, WITH WIRES	019427	1
13	UPPER ACTUATOR CLEVIS PIN, 1/4"x3/4"	019218	2
14	LOWER ACTUATOR CLEVIS PIN, 1/4"x1-3/8"	019219	2

■ WIRING DIAGRAMS

NOTE: A separate wiring diagram has been included with this manual and should be saved for troubleshooting and maintaining the fryer. The wiring diagrams in this section cover standard fryers which may or may not match the diagram sent with the fryer. Non-standard fryers such as CPU models and all 24" and 34"x24" BB and TS models do not have wiring diagrams printed in this section.

14 BB

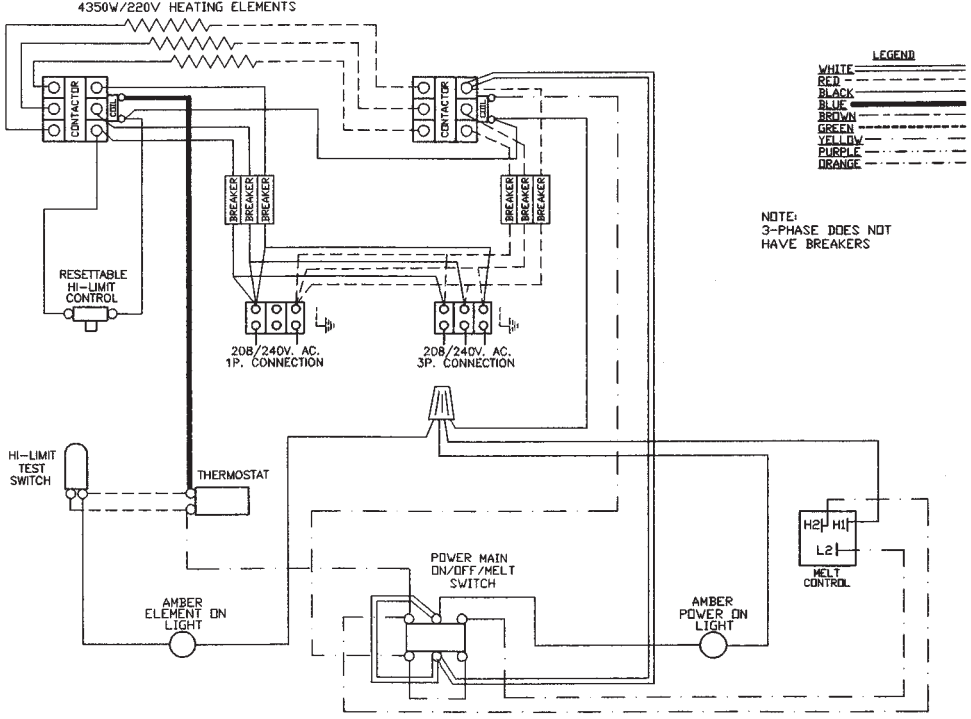

14 BB WITH WHIRL-O-SWIRL-A-WAY

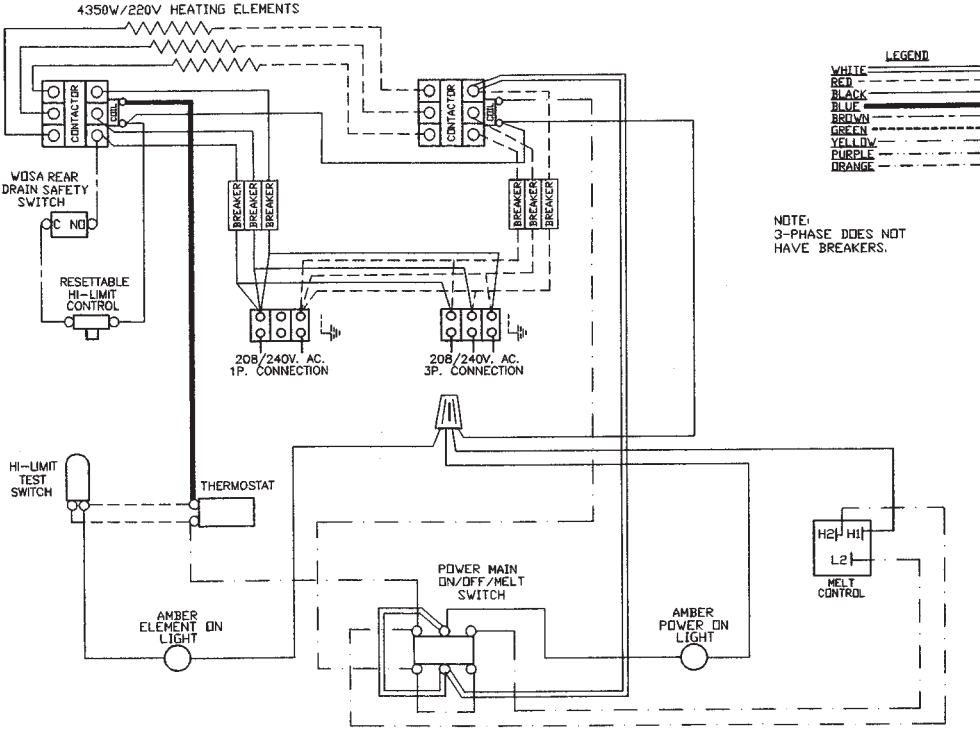

14 TS

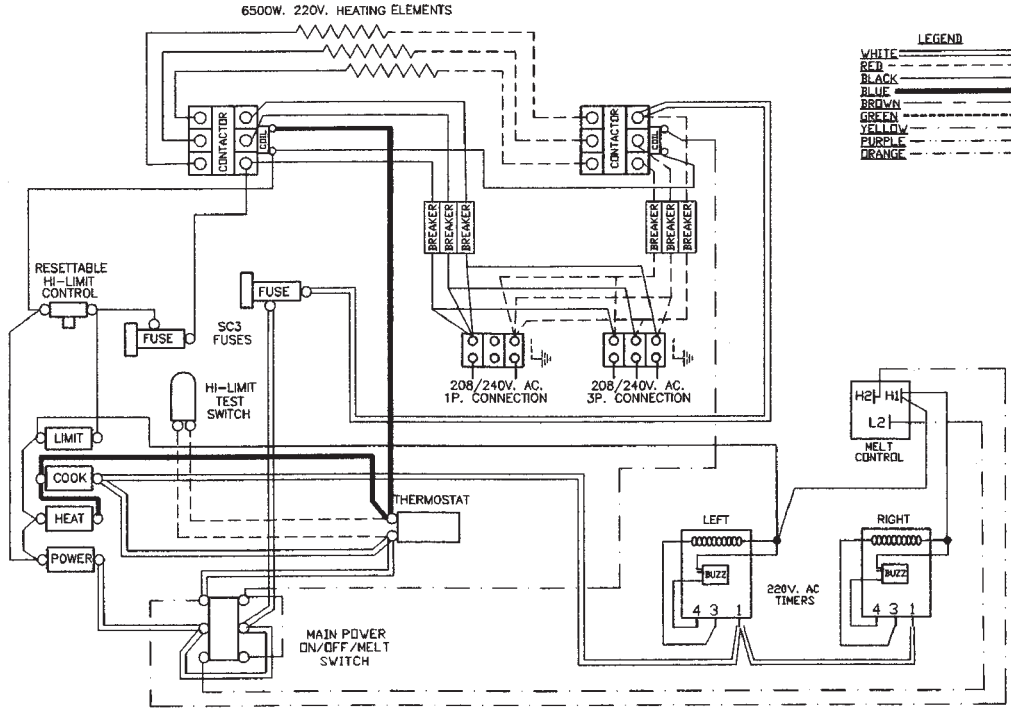

14 TS WITH WHIRL-O-SWIRL-A-WAY

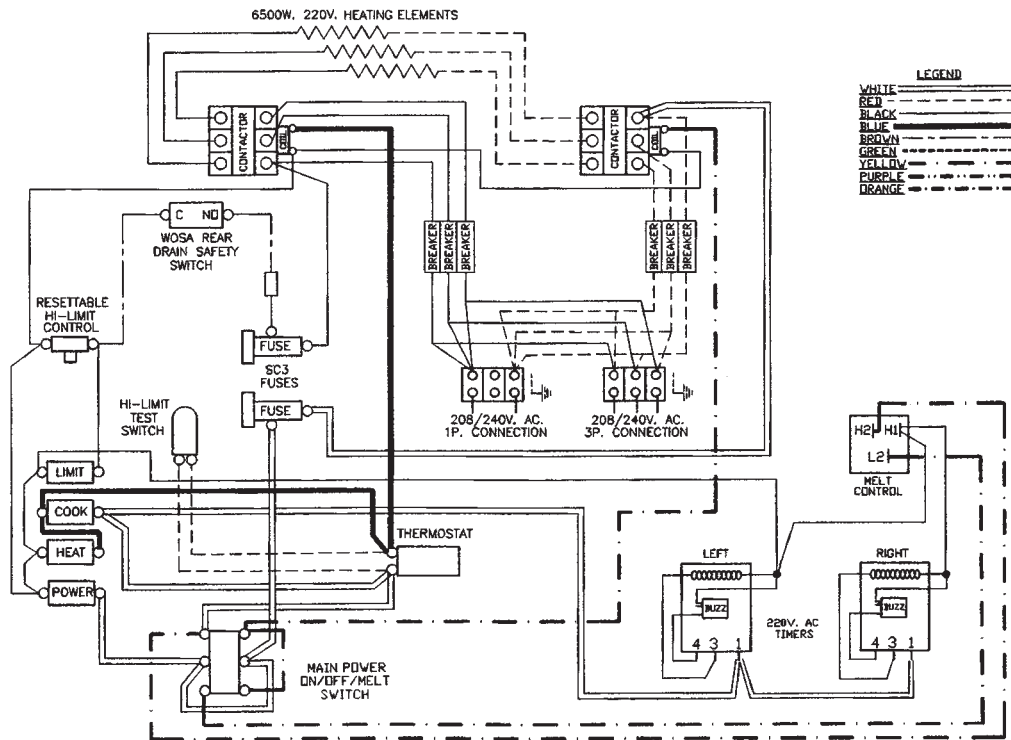

18, 20 TS

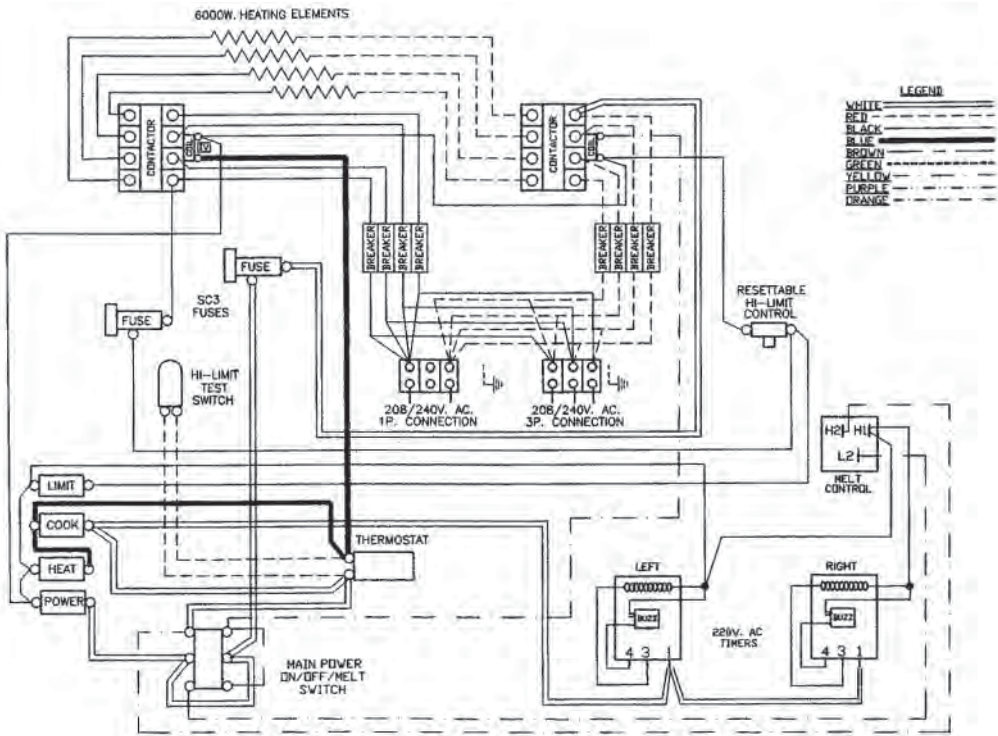

18, 20 TS WITH WHIRL-O-SWIRL-A-WAY

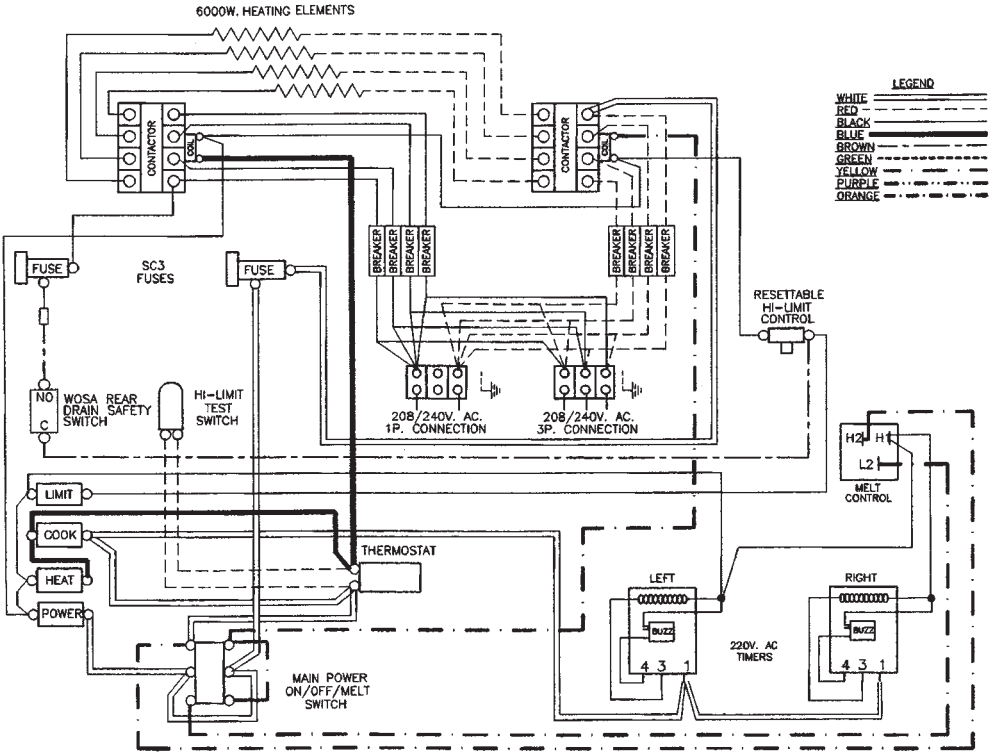

14 TS WITH BASKET-LIFT

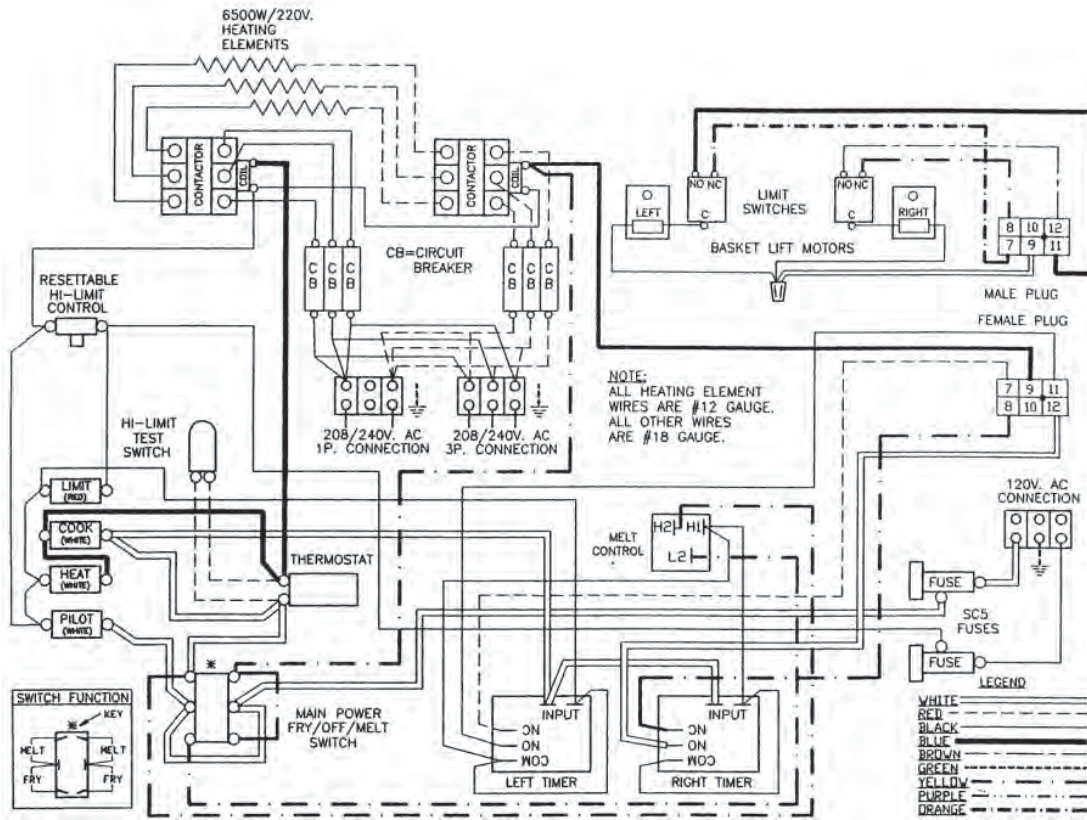

14 TS WITH BASKET-LIFT WITH WHIRL-O-SWIRL-A-WAY

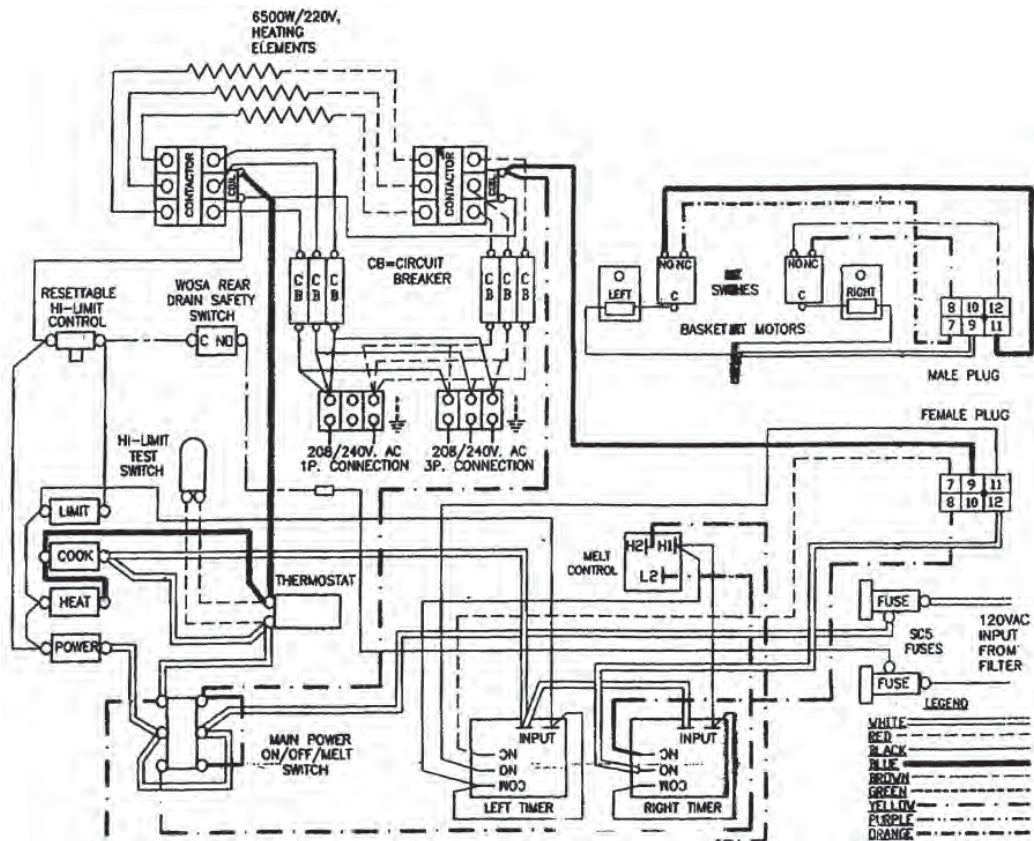

24 TS WITH BASKET-LIFT

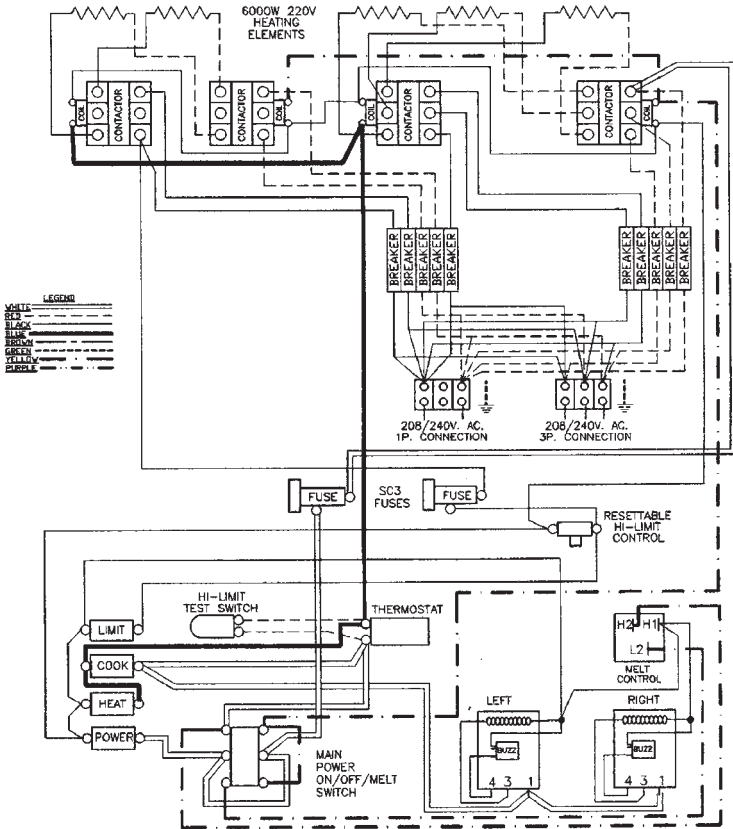

24 TS WITH BASKET-LIFT

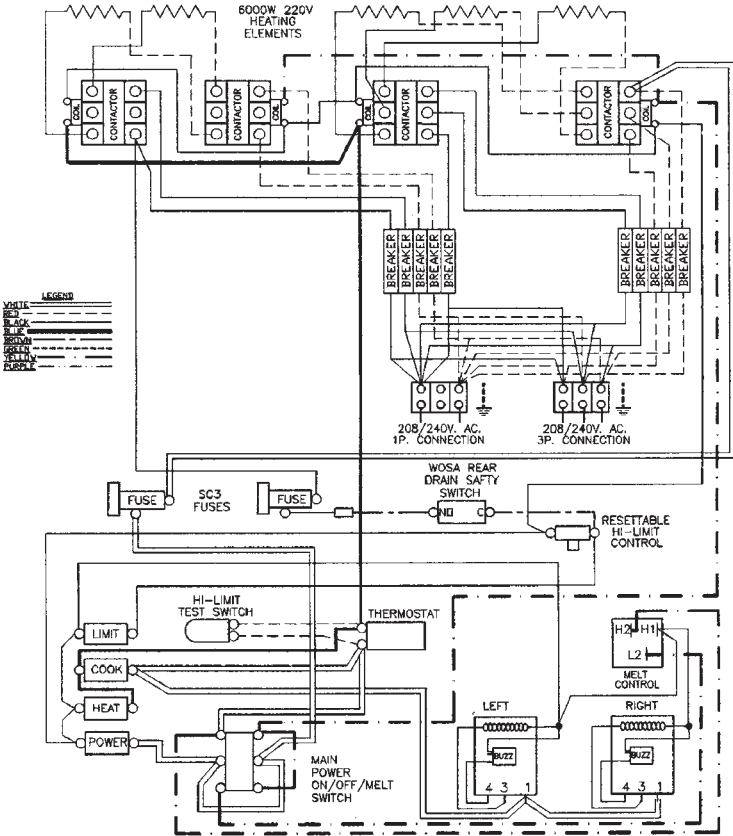

■ KEATING FRYER SPECIFICATIONS

BB FM-E MODELS:

10x11 BB FM-E

VOLTS	kW	AMPS PER LINE - THREE PHASE			AMPS SINGLE PHASE
		L1	L2	L3	
208	6.7	19	19	19	32
220	7.5	20	20	20	34
240	8.9	22	22	22	37

- 3 ELEMENTS (2500W EACH)

14 BB FM-E

VOLTS	kW	AMPS PER LINE - THREE PHASE			AMPS SINGLE PHASE
		L1	L2	L3	
208	11.7	32	32	32	56
220	13.1	34	34	34	59
240	15.5	37	37	37	65

- 3 ELEMENTS (4350W EACH)

18/20 BB FM-E

VOLTS	kW	AMPS PER LINE - THREE PHASE			AMPS SINGLE PHASE
		L1	L2	L3	
208	16.1	45	45	45	77
220	18.0	47	47	47	82
240	21.4	52	52	52	89

- 3 ELEMENTS (6000W EACH)
- 78 LB. OIL CAPACITY (18")
- 110 LB. OIL CAPACITY (20")

24 BB FM-E

VOLTS	kW	AMPS PER LINE - THREE PHASE			AMPS SINGLE PHASE
		L1	L2	L3	
208	21.5	68	68	45	103
220	24.0	72	72	47	109
240	28.6	79	79	52	119

- 4 ELEMENTS (6000W EACH)

34x24 BB

VOLTS	kW	AMPS PER LINE - THREE PHASE			AMPS SINGLE PHASE
		L1	L2	L3	
208	28.6	68	89	68	129
220	30.0	72	95	72	136
240	35.7	79	103	79	149
480	35.7	39	52	39	74

- 5 ELEMENTS (6000W EACH)
- 210 LB. OIL CAPACITY

* RATINGS ARE THE SAME FOR FLOOR MODELS AND COUNTER MODELS

TS MODELS:

10x11 TS FM-E

VOLTS	kW	AMPS PER LINE - THREE PHASE			AMPS SINGLE PHASE
		L1	L2	L3	
208	10.2	28	28	28	49
220	11.4	30	30	30	52
240	13.6	33	33	33	57

- 3 ELEMENTS (3800W EACH)

14 TS FM-E

VOLTS	kW	AMPS PER LINE - THREE PHASE			AMPS SINGLE PHASE
		L1	L2	L3	
208	17.4	48	48	48	84
220	19.5	51	51	51	89
240	23.2	56	56	56	97

- 3 ELEMENTS (6500W EACH)

18/20 TS FM-E

VOLTS	kW	AMPS PER LINE - THREE PHASE			AMPS SINGLE PHASE
		L1	L2	L3	
208	21.5	68	68	45	103
220	24.0	72	72	47	109
240	28.6	79	79	52	119

- 4 ELEMENTS (6000W EACH)
- 78 LB. OIL CAPACITY (18")
- 110 LB. OIL CAPACITY (20")

24 TS FM-E

VOLTS	kW	AMPS PER LINE - THREE PHASE			AMPS SINGLE PHASE
		L1	L2	L3	
208	26.8	68	89	68	129
220	30.0	72	95	72	136
240	35.7	79	103	79	149

- 5 ELEMENTS (6000W EACH)

34x24 TS FM-E

VOLTS	kW	AMPS PER LINE - THREE PHASE			AMPS SINGLE PHASE
		L1	L2	L3	
208	32.2	89	89	89	155
220	36.0	95	95	95	164
240	42.8	103	103	103	179

- 6 ELEMENTS (6000W EACH)
- 210 LB. OIL CAPACITY

* RATINGS ARE THE SAME FOR FLOOR MODELS AND COUNTER MODELS



WARRANTY

LIMITED WARRANTY

Keating of Chicago, Inc. ("Keating") warrants to the original purchaser, ("Customer"), all new Keating Fryers, Filter Systems, Griddles, Keep Krisp[®], Custom Pasta Systems, Top-Side[™] Cookers, Computer Timers, Fryer & Pasta Vessels and Keating replacement parts ("products") installed after June 1, 1994 to be free of defects in material or workmanship, subject to the following terms and conditions.

LENGTH OF WARRANTY

All products other than Fryer & Pasta Vessels and replacement parts shall be warranted for a period of one year from the date of original equipment installation. Keating replacement parts are warranted for a period of ninety days from the date of installation. Fryer & Pasta Vessels are warranted as described below.

FRYER & PASTA VESSEL WARRANTY

Fryers purchased after June 1, 1994 carry a prorated vessel warranty on defects in materials or workmanship to the Customer based on the following scale:

Time from Installation Date	Fryer Vessel Warranty Credit
13-60 months	100%
61-72 months	80%
73-84 months	60%
85-96 months	40%
97-108 months	20%
109-120 months	10%

The credit for the defective fryer & pasta vessel shall be applied against the cost of the replacement vessel, utilizing Keating's then current price, upon return of the vessel to Keating only during the first 60 months, subject to the limitations described below.

LIMITATIONS OF LIABILITY

In the event of warranty claim or otherwise, the sole obligation of Keating shall be the repair and / or replacement at the option of Keating of the product or component part thereof. Such repair or replacement shall be at the expense of Keating except that the Customer shall pay the following expenses: all freight and labor expense for Keating replacement parts; for all other products, mileage exceeding 50 miles or travel more than one hour, labor costs of more than one person, overtime rates, truck charges, difference between ground and other mode of transportation, and holiday charges. Any repair or replacement under this Limited Warranty does not constitute an extension of the original warranty for any period for the product or for any component or part thereof. Parts to be replaced under this Limited Warranty will be repaired at the option of Keating with new or functionally operative parts. Keep Krisps and Computer Timers must be returned to Keating for warranty repair or replacement. Field repairs of those items are not authorized.

THE LIABILITY OF KEATING ON ANY CLAIM OF ANY KIND, INCLUDING CLAIMS BASED ON WARRANTY, EXPRESSED OR IMPLIED, CONTRACT, NEGLIGENCE, STRICT LIABILITY OR ANY OTHER THEORIES SHALL BE SOLELY AND EXCLUSIVELY THE REPAIR OR REPLACEMENT OF THE PRODUCT AS STATED HEREIN, AND SUCH LIABILITY SHALL NOT INCLUDE, AND CUSTOMER SPECIFICALLY RENOUNCES ANY RIGHTS TO RECOVER, SPECIAL, INCIDENTAL, CONSEQUENTIAL OR OTHER INJURIES TO PERSONS OR DAMAGE TO PROPERTY, LOSS OF PROFITS OR ANTICIPATED PROFITS, OR LOSS OF USE OF THE PRODUCT.

If any oral statements have been made regarding the Keating products, such statements do not constitute warranties and are not part of the contract sale. This Limited Warranty constitutes the complete, final and exclusive statement with regard to warranties.

THIS LIMITED WARRANTY IS EXCLUSIVE AND IS IN LIEU OF ALL OTHER WARRANTIES WHETHER WRITTEN, ORAL, STATUTORY OR IMPLIED, INCLUDING BUT NOT LIMITED TO ANY WARRANTY OF MERCHANTABILITY OR FITNESS FOR PARTICULAR PURPOSE OR WARRANTY AGAINST LATENT DEFECTS.

EXCLUSIONS

The warranties provided by Keating of Chicago, Inc. do not apply in the following instances:

1. Defects arising out of or resulting from improper installation or maintenance, abuse, misuse, modification or alteration by unauthorized service personnel, or any other condition not attributable to a defect in material or workmanship. Proper installation and maintenance are the responsibility of the installer and Customer, respectively. Proper installation and maintenance procedures are prescribed by the Keating Service Manual.
2. In the event that the product was damaged after leaving the factory due to flood, fire, other acts of God or accident, damaged during shipment should be reported to the carrier and is not the responsibility of Keating.
3. In the event the serial number or rating plate has been removed from the product or altered.
4. On parts which would normally be worn or replaced under normal conditions, including but not limited to electric bulbs, fuses, interior and exterior finishes, gaskets and radiants.
5. With regard to adjustments and calibrations such as leveling, tightening of fasteners or plumbing connections, improper gas pressure or improper electrical supply, the checking of and changes in adjustment and calibrations are the responsibility of the installer. Proper installation procedures are prescribed by the Keating Service Manual.
6. In the event of unauthorized repairs or alterations to the Keating product.
7. With the use of sodium chloride in pasta vessels or harsh chemicals in fryer or pasta vessels.
8. Installation in Household.

OTHER TERMS AND CONDITIONS

The Customer must provide proof of purchase from Keating.

This Limited Warranty is valid in the 50 United States, its territories, and Canada, and is void elsewhere. Keating products are sold for commercial use only. If any Keating product is sold as a component of another product or used as a consumer product, such Keating product is sold As Is without any warranty.

If any provision of this Limited Warranty is held to be unenforceable under the law of any jurisdiction, such provision shall be inapplicable in such jurisdiction, and the remainder of the warranty shall remain unaffected. Further in such event, the maximum exclusion or limitation allowable under applicable law shall be deemed substituted for the unenforceable provision.

This Limited Warranty shall be governed by and construed in accordance with the laws of the State of Illinois.

TO SECURE WARRANTY SERVICE

All repair services under this Limited Warranty must be authorized by Keating or performed at Keating. Authorization may be obtained by calling 1-800-KEATING within the Continental United States, Alaska, Hawaii, Puerto Rico and Canada during normal business hours (8 a.m. through 5 p.m. Central Time, Monday through Friday). When calling, please have the following information available: (1) name, address and telephone number of the Customer; (2) location of product, if different; (3) name, model number and serial number of the product; (4) installation date; and (5) description of defect. Keating will then issue a service authorization work order number to one of its approved independent servicing organizations, or request the product or part be shipped to Keating for repair or replacement, as appropriate. Any defective part subject to a claim under this Limited Warranty must be shipped freight prepaid to Keating for testing and examination. Keating's decision as to the cause and nature of any defect under this Limited Warranty shall be final.

■ **SERVICE INFORMATION:**

If you have a service related question call **1-800-KEATING**.
Please state the nature of the call; it will ensure speaking with the appropriate person.

Have your serial and model number available when ordering parts.

As continuous product improvement occurs, specifications may be changed without notice.

.....
KEATING LIMITED WARRANTY CARD

PLEASE COMPLETE AND MAIL AT ONCE--WARRANTY IS NOT IN EFFECT UNTIL CARD IS RETURNED, OR COMPLETE THE WARRANTY CARD ON OUR WEBSITE FOR YOUR CONVENIENCE.

COMPANY: _____

ADDRESS: _____

CITY: _____ STATE: _____ ZIP CODE: _____

DEALER NAME: _____

DATE OF PURCHASE: _____ INVOICE #: _____

SERIAL #: _____ MODEL: _____

FRYER GRIDDLE CUSTOM PASTA
 FILTER SYSTEM TOP-SIDE COOKER HOTPLATE

I HAVE READ THE INSTALLATION AND OPERATING INSTRUCTIONS.

SIGNED: _____ DATE: _____



KEATING OF CHICAGO, INC.
8901 West 50th Street
McCook, IL 60525-6001

1-800-KEATING
PHONE: 708-246-3000
FAX: 708-246-3100

Serving Those Who Serve the Very Best®