



**INCREDIBLE FRYING MACHINE™
GAS FRYER
SERIES 2013**

MANUAL

IMPORTANT:

THE USER'S MANUAL PROVIDES SPECIFIC OPERATING INSTRUCTIONS FOR YOUR MODEL. USE THE INCREDIBLE FRYING MACHINE™ ONLY AS INSTRUCTED IN THIS MANUAL.

KEEP A COPY OF YOUR BILL OF SALE.

The date on the bill establishes the warranty period should service be required. If service is performed, it is in your interest to obtain and keep all receipts.

KEEP THIS MANUAL FOR TRAINING NEW PERSONNEL.

Record the Serial number and Model number of this Incredible Frying Machine™ in the spaces provided. **Keep these numbers for future reference.**

SERIAL NUMBER

MODEL NUMBER

Keating commercial fryers are not intended for household use.

As continuous product improvement occurs, specifications may be changed without notice.

1-800-KEATING | keatingofchicago.com

NOTE:

PURCHASER SHOULD POST IN A PROMINENT LOCATION INSTRUCTIONS TO BE FOLLOWED IN THE EVENT THE USER SMELLS GAS. THIS INFORMATION SHALL BE OBTAINED BY CONSULTING THE LOCAL GAS SUPPLIER.



⚠ WARNING

Improper installation, adjustment, alteration, service or maintenance can cause property damage, injury or death. Read the installation, operating and maintenance instructions thoroughly before installing or servicing this equipment.



FOR YOUR SAFETY:

Do not store or use gasoline or other flammable vapors or liquids in the vicinity of this or any other appliance.

⚠ WARNING

IF NOT INSTALLED, OPERATED AND MAINTAINED IN ACCORDANCE WITH THE MANUFACTURER'S INSTRUCTIONS, THIS PRODUCT COULD EXPOSE YOU TO SUBSTANCES IN FUEL OR IN FUEL COMBUSTION WHICH CAN CAUSE DEATH OR SERIOUS ILLNESS AND WHICH ARE KNOWN TO THE STATE OF CALIFORNIA TO CAUSE CANCER, BIRTH DEFECTS OR OTHER REPRODUCTIVE HARM.

⚠ WARNING

PROPANE GAS MAY EVENTUALLY LOSE ITS ODOR AND PRECAUTIONS SHOULD BE TAKEN TO ASSURE THAT PROPANE GAS IS NOT PRESENT EVEN THOUGH YOU DO NOT DETECT AN ODOR. IF THERE IS ANY DOUBT, YOU SHOULD CALL YOUR LOCAL PROPANE GAS SUPPLIER FOR ASSISTANCE.

THE EQUIPMENT IS TO BE INSTALLED TO COMPLY WITH THE BASIC PLUMBING CODE OF THE BUILDING OFFICIALS AND CODE ADMINISTRATORS INTERNATIONAL, INC. (BOCA) AND THE FOOD SERVICE SANITATION MANUAL OF THE FOOD AND DRUG ADMINISTRATION (FDA).



■ TABLE OF CONTENTS

Important Safety Instructions	i	Digital Timer	7
INTRODUCTION	1	Draining.....	8
INSTALLATION		Cleaning and Boil-Out	8
Damage During Shipment	1	PREVENTATIVE MAINTENANCE	
Standard Features.....	2	Warranty Repairs	9
Safety Precautions	2	Preventive Maintenance Chart	9
FIRST STEPS		Oil Breakdown	9
National Code Requirement	2	Thermostat Calibration	9
Leveling.....	2	Thermostat Bulb Positioning.....	9
Restraining Devices.....	3	SERVICE	
Electrical Connection	3	SELF HELP GUIDE	11
Gas Connection	5	SERVICE DIAGNOSIS	
Gas Pressure Tap	5	Troubleshooting.....	12 - 13
Gas Leak Testing.....	6	ORDERING PARTS	14
PLACING YOUR KEATING FRYER IN OPERATION		Warning and Operating Plates.....	14
Filling	6	Parts List.....	14 - 21
Lighting	6	Wiring Diagrams	22 - 27
Cooking.....	7	Warranty Information	28
Shutdown	7		

■ INTRODUCTION

Instructions in this manual should be read thoroughly before attempting to operate this Keating Gas Fryer. All installation and service on Keating equipment must be performed by qualified, certified, licensed and/or authorized installation or service personnel.

Operating information for Keating equipment has been prepared for use by qualified and/or authorized personnel.

Keating equipment is made in the USA and has American sizes of hardware. All metric conversions are approximate.

■ INSTALLATION INSTRUCTIONS

Proper installation will assure top performance. Alterations of any kind to your equipment will void the warranty. Before uncrating, check equipment carefully for damage.

IF EQUIPMENT ARRIVES DAMAGED

Keating does not assume responsibility for loss or damage incurred in transit.

IMPORTANT

This merchandise has been thoroughly inspected and carefully packed before leaving our plant. Responsibility for its safe delivery was assumed by the carrier at the time of shipment. Claims for loss or damage to the contents should, therefore, be made upon the carrier, as follows:

CONCEALED LOSS OR DAMAGE

Concealed loss or damage means loss or damage which does not become apparent until the merchandise has been unpacked. The contents may be damaged in transit due to rough handling even though

the carton may not show external damage. When the damage is discovered upon unpacking, make a written request for inspection by the carrier's agent within fifteen days of the delivery date. Then file a claim with the carrier since such damage is the carrier's responsibility. By following these instructions carefully, we guarantee our full support of your claims to protect you against loss from concealed damage.

VISIBLE LOSS OR DAMAGE

Any external evidence of loss or damage must be noted on the freight bill or express receipt, and signed by the carrier's agent. Failure to adequately describe such external evidence of loss or damage may result in the carrier refusing to honor a damage claim. The form required to file such a claim will be supplied by the carrier.

DO NOT RETURN DAMAGED MERCHANDISE TO KEATING. FILE YOUR CLAIM AS STATED ABOVE.

Keating's Incredible Frying Machine® (IFM) is designed to give maximum production efficiency, delivering high quality food products. The following design features are incorporated in Keating's Incredible Frying Machine® (IFM).

STANDARD FEATURES

- Highly polished stainless steel fryer vessel
- Highly polished stainless steel front
- Highly polished stainless steel transfer tubes
- Highly polished stainless steel thermostat bulb
- Highly polished stainless steel Hi-Limit bulb
- Complete stainless steel cabinet
- True Cold Zone for proper sedimentation
- Grid screen over heat transfer tubes
- 1" full port front drain valve
- Patented accurate temperature control system $\pm 2^{\circ}\text{F}$
- Ideal 35" working height
- One pair of split baskets or one full-size basket (18" model only)
- 3/4" NPT gas connection on single fryers
- Patented burner design
- Dual spark gas ignition control
- 100% proof of air flow safety shut-off
- 100% proof of flame safety shut off
- Digital timers (2) (where applicable)
- Gas and air adjustments
- Gas pressure test port
- Blower grease filter (easily accessible from front)
- Easy access for servicing from front of fryer
- Burner, blower and Hi-Limit indicating lights
- Insulated fryer vessel
- Heat recirculation for higher efficiency and lower flue temperature
- Instant-On™ immediate thermostat response
- 120 VAC 9' neoprene cord with 3-pronged grounded plug
- Instant recovery to cooking temperature
- High temperature stainless steel flue lining
- 100% factory testing

STANDARD ACCESSORIES

- Keating Klenzer Sample
- Drain clean out rod

OPTIONS

- Natural Gas or Propane
- Automatic Basket-Lift
- Cooking Computer

RATINGS

- 14" fryer vessel - 38 lb. oil capacity
- 18" fryer vessel - 68 lb. oil capacity
- 20" fryer vessel - 100 lb. oil capacity
- 7" W.C. (Natural Gas) or 11" W.C. (Propane) Line Gas Pressure
- 3" WC (Natural Gas) or 10" WC (Propane) Manifold Gas Pressure
- 3/4" gas supply pipe recommended

MODEL VARIATIONS

Basket-Lift Model: Basket-Lift Model Fryers come with all the same features as the standard models. The Basket-Lift mechanism lowers the baskets of food into the oil when the timer button is pressed and raises the baskets when the cooking cycle is complete. Split baskets are required for these models.

CPU Model: CPU Incredible Frying Machine (IFM) have the same input as the standard models. A programmable computer replaces the two timers and thermostat.

SAFETY PRECAUTIONS

⚠ WARNING

THIS SYMBOL WARNS YOU THAT SERIOUS BURNS OR OTHER INJURIES MAY RESULT IF SAFETY INSTRUCTIONS ARE NOT FOLLOWED.

- This service manual should be retained in a safe place for future reference. The installation of your new fryer must conform to local codes or in the absence of local codes, with the current National Fuel Gas Code ANSI Z223.1/NFPA 54 (latest edition), Natural Gas Installation Code CAN/CGA-B149.1 or Propane Installation Code CAN/CGA-B149.2.
- Your ventilation hood, when installed, must conform to the current ANSI/NFPA 96 standard (latest edition).
- No frame or restriction shall be constructed around the fryer that will restrict air movement into the fryer's combustion area or prevent proper ventilation.

- Keating fryers are designed to operate on the gas fuel specified on the serial plate and must not be operated with another gas fuel. They cannot be converted to another gas fuel by turning or engaging a switch.

⚠ WARNING

DO NOT STORE OR USE GASOLINE OR OTHER FLAMMABLE VAPORS AND LIQUIDS IN THE VICINITY OF THIS OR ANY APPLIANCE.

You will post, in a prominent location, instructions to be followed in the event the user smells gas. This information shall be obtained from your local gas supplier.

IMPORTANT: IN THE EVENT A GAS ODOR IS DETECTED, SHUT DOWN UNIT AT MAIN SHUT-OFF VALVE AND CONTACT THE LOCAL GAS COMPANY OR GAS SUPPLIER FOR EMERGENCY SERVICE.

- Suitable for installation on non-combustible floors.
- You must maintain this appliance free and clear from combustibles.
- You must maintain the following minimum clearances from combustible and non-combustible construction:

MINIMUM CLEARANCE

CONSTRUCTION CLEARANCES		
	COMBUSTIBLE	NON-COMBUSTIBLE
BACK	6"	0"
RIGHT SIDE	6"	0"
LEFT SIDE	6"	0"

SUITABLE FOR NON-COMBUSTIBLE FLOORS

- You must install this appliance at least 16 inches away from any open flame.
- Adequate clearance for servicing and proper operation must be maintained. Your fryer is designed to be serviced from the front.
- Keating commercial fryers are not intended for household use.
- ALWAYS instruct new employees on proper fryer operation.
- A fryer should be operated ONLY by properly trained personnel.
- ALWAYS turn fryer off each night.
- ALWAYS turn fryer off at customer power panel before servicing.
- ALWAYS disconnect fuel source before servicing.
- NEVER leave a fryer unattended during operation.
- NEVER move a fryer when full of hot oil.

- NEVER introduce objects or liquids into fryer, while operational, which are not designed or made for cooking.
- THIS FRYER MAY NOT BE ALTERED, MODIFIED OR CHANGED IN ANY WAY.

The State of California enacted the California Safe drinking water and Toxic Enforcement Act of 1986, (Prop. 65), which “prohibits any person in the course of doing business from knowingly and intentionally exposing any individual to a chemical known to the State of California to cause cancer or reproductive toxicity without first giving clear and reasonable warning to such individuals.” The Governor’s Scientific Advisory Panel added carbon monoxide to the list of hazardous chemicals known to cause reproductive harm.

Carbon monoxide would not be present in concentrations that would pose a “significant risk” to the consumer when the equipment is installed, operated and maintained as follows:

- Installed in accordance with all local codes, or in the absence of local codes, with the current National Fuel Gas Code ANSI Z223.1/NFPA 54 (latest edition).
- Installed under a properly designed operating exhaust hood.
- Connected to the type of gas for which the appliance is manufactured.
- In-line pressure regulator, not supplied by Keating, must be installed outside the appliance to maintain proper incoming gas pressure (7" W.C. Natural, 11" W.C. L.P).
- The appliance is adjusted for the manifold pressure marked on the serial plate.
- Adequate air supply to the appliance.
- The equipment is operated in the manner intended using the proper utensils.
- Keep the equipment clean and have it checked periodically.
- Burner air adjustments, mechanical maintenance and repairs must be performed by qualified service personnel.

If the equipment is not installed, operated and maintained in accordance with the above, concentrations of carbon monoxide in excess of the established limits could be present in the kitchen environment.

■ FIRST STEPS

NATIONAL CODE REQUIREMENT

The installation must conform with local codes, or in the absence of local codes, with the National Fuel Gas code, ANSI Z223.1 or the Natural gas Installation Code, CAN/CGA-B149.1 or the Propane Installation Code, CAN/CGA-B149.2. Flexible connectors must comply to ANSI Z221.69/CAN/CGA1.16.

When pressure testing at test pressures less than or equal to 1/2 psig (3.45 KPA), fryer **must be isolated** from gas supply piping. When pressure testing at test pressures above 1/2 psig (3.45 KPA), fryer **must be disconnected** from gas supply piping system.

LEVELING

The fryer will operate at its highest efficiency when properly leveled. Place a level on fryer vessel from side to side. For fryers on legs, the bottom foot of the leg is adjustable. Turn clockwise to decrease height or counter clockwise to increase height until level. For fryers on casters, the casters are adjustable by loosening the jam nut and turning the caster in or out. When the desired level is reached, tighten the jam nut. Adjustments of more than 3/4" are not recommended on any caster. The same procedure should be followed to level the fryer from front to back.

Figure 1

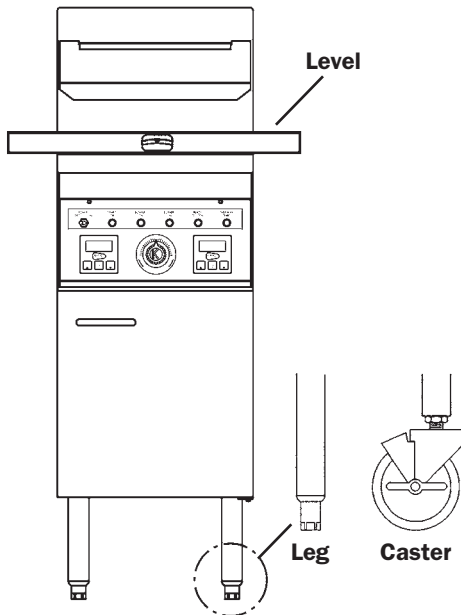

RESTRAINING DEVICES

1. Adequate means must be provided to limit the movement of the appliance without depending on the connector and the quick-disconnect device or its associated piping to limit the appliance movement.



Fryer must also be restrained to prevent tipping when installed so that hot liquid splashing is avoided.

2. The restraint means must be attached to the rear of the Keating Gas Fryer within 2" of the center line width and approximately 1-5/8" from the bottom of the cabinet back to allow the restrain-

ing bolt to be anchored to the cabinet back between the cabinet bottom and inner liner.

If disconnection of the restraint is necessary, it must be reconnected when the Keating IFM is returned to its originally installed position.

NOTICE: WHEN THIS APPLIANCE IS INSTALLED WITH CASTERS, IT MUST BE INSTALLED WITH CASTERS SUPPLIED, A CONNECTOR COMPLYING WITH EITHER ANSI Z21.69 OR CAN/CGA-6.16 AND A QUICK-DISCONNECT DEVICE COMPLYING WITH EITHER ANSI Z21.41 OR CSA-6.9. IT MUST ALSO BE INSTALLED WITH RESTRAINING MEANS TO GUARD AGAINST TRANSMISSION OF STRAIN TO THE CONNECTOR, AS SPECIFIED IN THE APPLIANCE MANUFACTURER'S INSTRUCTIONS.

ELECTRICAL CONNECTION

The Keating IFM, when installed, must be electrically grounded in accordance with local codes, or in the absence of local codes, the National Electrical Code, ANSI/NFPA No. 70. or the Canadian Electrical Code, CSAC-22.2 as applicable. A wiring diagram is located on the last page. In the USA and Canada, the electrical supply must be 120 VAC, 60 Hz.

The Keating Incredible Frying Machine (IFM) is equipped with a 9' neoprene covered, 3 wire electrical cord with a three-pronged grounded plug for protection against electrical shock. This plug must be placed into a 120V properly grounded three-pronged polarized outlet. For proper grounding procedures see local codes, or in the absence of local codes, the National Electrical Code ANSI/NFPA 70 (latest edition) or Canadian Electrical Code CAN 22.2 (latest edition) as applicable.

! WARNING

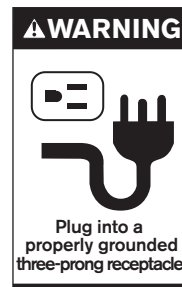

THIS APPLIANCE IS EQUIPPED WITH A THREE-PRONG 120 VOLT NEMA 5-15 (GROUNDING) PLUG FOR YOUR PROTECTION AGAINST SHOCK HAZARD AND SHOULD BE PLUGGED DIRECTLY INTO A PROPERLY GROUNDED AND POLARIZED THREE-PRONG RECEPTACLE. DO NOT CUT OR REMOVE THE GROUNDING PRONG FROM THIS PLUG.

⚠ CAUTION

Before plugging in the fryer, confirm the outlet is properly polarized and grounded. If the hot and neutral terminals are reversed or the outlet is not properly grounded, the burners may not ignite (burner on light will go out after 2-1/2 seconds and the ignition processes will continue 3 times).

⚠ WARNING

IF DISCONNECTION OF THE RESTRAINT IS NECESSARY, IT MUST BE RECONNECTED WHEN THE FRYER IS RETURNED TO ITS ORIGINALLY INSTALLED POSITION.

GAS CONNECTION

⚠ WARNING

IF YOU HAVE 2 PSI GAS AT YOUR LOCATION, YOU SHOULD CONTACT THE MAXITROL COMPANY FOR THE PROPER LINE PRESSURE REGULATOR (ph: 248-356-0829).

- PIPE JOINT COMPOUNDS RESISTANT TO PROPANE GASES MUST BE USED.
- BEFORE OPERATING THIS FRYER, CHECK PIPE JOINTS FOR LEAKS BY USING A SOAP AND WATER SOLUTION ONLY. DO NOT USE AN OPEN FLAME!

Figure 2
Main Gas Connection

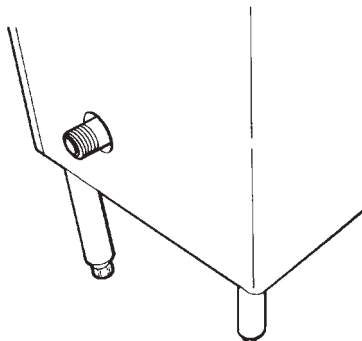

Connect the fryer to the main gas supply line at the rear of the fryer. The piping should be a minimum of 3/4" NPT supply pipe for a single fryer at the burner manifold. Batteries require larger supply lines. Installation must conform to the current local codes and National Fuel Gas Code (U.S.) ANSI Z223. 1/NFPA 54 (latest edition), Natural Gas Installation Code CAN/CGA-B149.1 or Propane Installation Code CAN/CGA-B149.2 (latest edition).

NOTE: If more than one gas fryer is on the same supply line, you may require a larger line. Consult your local gas company to assure adequate volume and pressure. Refer to serial plate for proper gas requirements for your particular model.

NOTE: Piping for a battery should be at least 1-1/4" to 1-1/2" IPS, depending on total BTU input. Consult your local gas supplier for appropriate battery piping size.

GAS PRESSURE TAP

INSTRUCTIONS FOR USING THE GAS PRESSURE TAP INCLUDED ON FRYER BATTERY WITH COMMON MANIFOLD MANUFACTURED AFTER 8/19/10 (Part #060265)

The gas pressure tap is available on battered fryers with common manifold piping manufactured after 8/19/10. Keating batteries are often equipped with a common manifold that supplies gas to each product in the battery requiring only a single service supply hook-up. A pressure tap is now provided at this service hook-up end. Use this tap to confirm there is at least 7" WC gas pressure for natural gas and 11" WC gas pressure for LP (propane) gas when all battery gas burners are running.

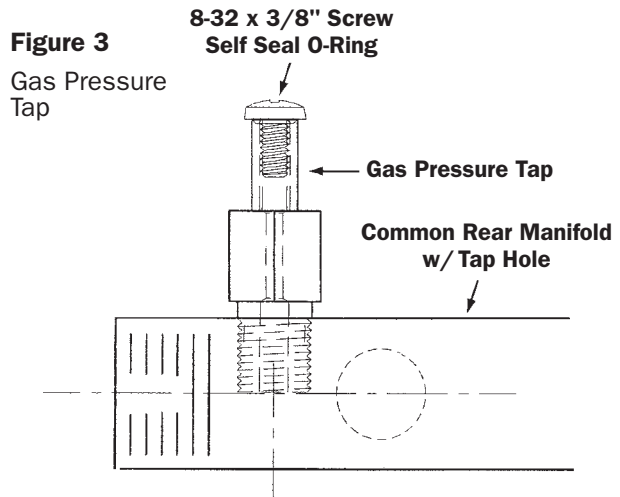

Figure 3

Gas Pressure Tap

1. Remove the self-sealing screw and hook-up 1/8" NPT hose to a pressure measuring meter.
2. Turn on the gas supply.
3. Turn on each gas product in the battery so that all burners are on.
4. Measure the gas supply pressure and ensure that it is at least 7" WC for natural gas and 11" WC for LP (propane) gas. (Gas pressure must NOT be greater than 14" WC whether burners are on or off.)

NOTE: When installing pressure tap, use gas-rated sealant on tap threads. Only use sealant on threads that contact the manifold pipe. Excess sealant may come loose and clog downstream gas valves or orifices. Clean away any pipe debris or loose sealant after installing gas pressure tap.

BE SURE TO REPLACE AND TIGHTEN THE SELF-SEALING SCREW IN THE TAP EITHER TIGHTEN SELF-SEALING SCREW BY HAND, OR TIGHTEN WITH SCREWDRIVER, BUT JUST SLIGHTLY PAST THE POINT OF GASKET COMPRESSION TO AVOID DAMAGING THE O-RING SEAL. CHECK THE TAP AND ALL INSTALLED PIPING AND GAS CONNECTIONS FOR LEAKS BEFORE RELEASING THE BATTERY FOR CUSTOMER USE.

NOTE: The electrical wiring diagram for the fryer is located on the inside of the fryer door or in the back of this manual.

GAS LEAK TESTING

Prior to lighting your fryer:

1. Make sure all thermostats, switches and safety valves are in the “OFF” position.
2. Turn main On/Off manual gas valve to the “ON” position.
3. Have your plumber or gas company check for leaks with a soap solution. (NEVER check with an open flame!)

GAS PRESSURE AT MANIFOLD

NATURAL Gas - 3.0 in. W.C.

LP Gas - 10.0 in. W.C.

MINIMUM INCOMING GAS PRESSURE

NATURAL Gas - 7.0 in. W.C.

LP Gas - 11.0 in. W.C.

NOTE: It is estimated that half of all service calls made on Keating Incredible Frying Machine™ (IFM) result from an inadequate gas supply. During installation, have a gas company representative make certain that the fryer is receiving adequate gas pressure and volume (see “Installation” or your serial plate on the fryer door).

⚠ WARNING

PROPANE GAS MAY EVENTUALLY LOSE ITS ODOR AND PRECAUTIONS SHOULD BE TAKEN TO ASSURE THAT IT IS NOT PRESENT EVEN THOUGH YOU DO NOT DETECT AN ODOR. IF THERE IS ANY DOUBT, YOU SHOULD CALL YOUR LOCAL PROPANE GAS SUPPLIER FOR ASSISTANCE.

■ OPERATING

FILLING

NOTE: Before filling the fryer make certain the fryer vessel is sanitized, dry and the drain valve is completely closed. Refer to item 11 on page 15 for location of drain valve.

NOTE: We recommend that solid shortening not be used in an Incredible Frying Machine (IFM) as they are not equipped with a melt cycle. If solid shortening is used, it should be melted prior to filling the fryer vessel. Damage done by melting solid shortening in the fryer vessel will void the warranty.

⚠ WARNING

BE SURE THE HEAT TRANSFER TUBES ARE COMPLETELY COVERED WITH OIL BEFORE SWITCHING THE FRYER ON. IF OIL LEVEL DROPS BELOW TOP OF HEAT TRANSFER TUBES, SEVERE DAMAGE TO FRYER AND INJURY TO OPERATOR MAY RESULT.

⚠ WARNING

WATER IN ANY FORM AND HOT OIL DON'T MIX!

⚠ CAUTION

OIL EXPANDS WHEN HEATED. THE MAX LEVEL LINE HAS BEEN PROVIDED TO ENSURE OPTIMUM COOKING WHILE ENSURING THE SAFETY OF THE OPERATOR. DO NOT OVERFILL THE FRYER VESSEL.

Figure 4

MAX Level Line

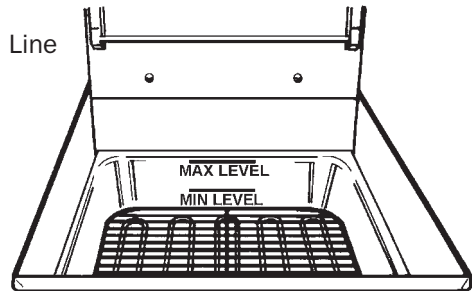

Fill the fryer vessel with oil or MELTED solid shortening up to the “Max” line.

LIGHTING

⚠ WARNING

BEFORE ATTEMPTING TO LIGHT THE FRYER, MAKE SURE THE GAS CONNECTIONS ARE SECURE AND HAVE BEEN LEAK TESTED AND THE FRYER HAS BEEN PROPERLY FILLED WITH OIL.

Figure 5

Model 2013 - Control Panel with timers

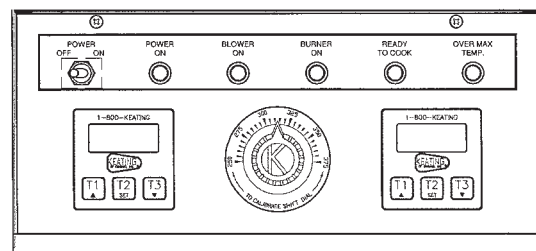

1. Turn on main power switch.
2. Set thermostat to desired setting. (Between 325°F/162.8°C – (335°F/165.3°C)
3. Once main power switch is on and the thermostat is set, the following occurs:
 - a. Blower will start and blower indicating light will come on.
 - b. After a preset 15 second delay, the gas valve will open and the burner indicating light will come on.
 - c. The spark module will light the burners automatically.

- d. The burner indicating light will be on whenever the burners are on. The light goes off when the oil has reached the desired temperature. If the burners do not light immediately, the burner light will shut off, the blower light will stay on, and after 15 seconds, the burners will try to light again. This process will repeat 3 times.

NOTE: The fryer cannot be operated during a power failure as the electronic ignition system cannot be operated.

COOKING

Keating Incredible Frying Machine® Gas Fryers (IFM) are designed to provide maximum production efficiency and deliver high quality food products.

Low-temperature cooking, highly polished stainless steel and a true COLD ZONE mean extended oil life. Follow cooking procedures below for your model.

⚠ WARNING

- **OPERATION OF THIS FRYER SHOULD BE LIMITED TO PERSONNEL WHO HAVE BEEN THOROUGHLY TRAINED IN OPERATING PROCEDURES.**
- **USE ONLY KEATING APPROVED BASKETS IN YOUR FRYER. NEVER OVERFILL FRY BASKETS. DO NOT BANG BASKETS ON BASKET HANGERS OR ON FRYER VESSEL.**
- **CARE SHOULD BE TAKEN WHEN LOWERING BASKETS INTO FRYER TO PREVENT SPLASHING HOT OIL FROM FRYER VESSEL.**
- **NEVER LIFT BASKETS DIRECTLY OUT OF THE FRYER VESSEL WITHOUT DRAINING, AS SEVERE INJURY MAY RESULT.**

1. Set thermostat to the desired frying temperature (between 325°F - 335°F).
2. When the oil reaches the desired temperature, burner indicating light will go off.
3. Set timer(s) to desired cooking time and fill basket(s) to proper level (if applicable).
4. Lower filled basket(s) slowly into oil. For fryers with automatic basket lift, place basket(s) on upper basket hanger rods on splashback of fryer.
5. Push "T1", "T2" or "T3" button of electronic timer(s). This simultaneously activates the Instant-On™ systems. For fryers with automatic basket lift, basket(s) will lower into fryer vessel.
6. When timer(s) sounds, carefully lift basket(s) out of hot oil (if applicable). For fryers with automatic basket lift, a buzzer will sound and the basket(s) will rise automatically. Allow oil to drain before removing.
7. Place basket(s) on basket hanger rods on splashback of fryer and allow to drain.

SHUT DOWN

Turn off main power switch.

DIGITAL TIMER

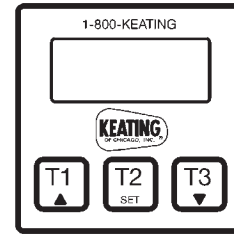

PROGRAMMING

To program the timers, the unit must be in the idle mode. Press and hold the set button for approximately two seconds. The display will show "SEt". Press the T1, T2 or T3 for the cook time to be programmed. The display will show the current setting for that cook time. Use the up or down button to increment or decrement the setting. When the setting is correct, press and hold the set button again for approximately two seconds. The display will show "StO" for approximately two seconds and the timer will return to normal operation. Repeat the process as necessary for the other timers.

OPERATING LOGIC

When the timer is powered up, the display will show the time setting for the cook time that was operated last and the relay output contacts will be open. To start a cycle, press the desired cook time button (T1, T2 or T3). The display will begin to countdown from the preset time setting and the relay output contacts will close. During the countdown the colon will flash at a one-second rate. When the countdown has reached "00:00" the relay output contacts will open, the display will flash, and the audible alarm will sound. To cancel the audible alarm, press any button.

PAUSE FEATURE

To pause a cycle in progress, press any button. The relay output contacts will open, the display will flash, and the countdown will pause. To resume the countdown, press any button. The display will resume the normal countdown and the relay output contacts will close.

CANCELING A CYCLE

To cancel a cycle in progress press and hold any button for approximately two seconds. The relay output contacts will open and the display will show the time setting for the cook time last used.

DRAINING

⚠ WARNING

ALWAYS SHUT THE FRYER OFF COMPLETELY BEFORE DRAINING. THE FRYER SHOULD BE DRAINED ONLY UNDER THE SUPERVISION OF PROPERLY TRAINED PERSONNEL. A DRAIN PIPE AND COVERED CONTAINER SUITABLE FOR USE WITH HOT OIL SHOULD BE USED TO ENSURE THE SAFETY OF THE OPERATOR.

1. Operator should be outfitted with proper attire including:
 - Oil and heat resistant gloves
 - Oil and heat resistant apron
 - Safety goggles
 - Oil and heat resistant footwear



Figure 6

Side view of Safe & Easy® Filter

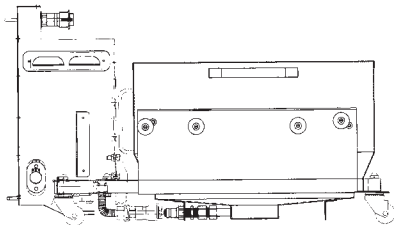

2. Turn off the fryer and open the door.
3. Put suitable container under drain valve (for Safe & Easy models, slide filter onto rails inside of fryer or filter cabinet).
4. • **Front Drain:**
Drain oil from fryer by slowly turning handle. The drain will be completely open after 1/4 turn.
 - **Rear Drain:**
Pull black knob forward slowly.
5. After fryer drains, close the drain valve.
6. Filtering may be done at this step - refer to filter manual.

CLEANING AND BOIL-OUT

Figure 7

Keating Klenzer and Sea Powder



When cleaning and boiling out your fryer use Keating Sea Powder and Keating Klenzer to keep your fryer in top condition. Keating Sea Powder dissolves any grease build up - even carbonized grease in fryer vessels - one of the leading causes of premature oil breakdown. Once your fryer vessel is clean, use Keating Klenzer, the finest dry stainless steel polish available, to restore your Keating Incredible Frying Machine®'s (IFM) exterior to its original luster.

1. Put on safety attire. See Draining.
2. Turn the fryer off.
3. Drain oil from fryer, see draining steps 2-4.
4. Remove oil container to a secure area to prevent accidental spillage.
5. Fill fryer vessel to "Max" line with water.

⚠ WARNING

UNDER NO CIRCUMSTANCES SHOULD THE FRYER BE LEFT UNATTENDED DURING BOIL-OUT. TRAINED PERSONNEL MUST BE PRESENT DURING THE PROCEDURE TO PREVENT BOIL OVER OR TO TURN OFF THE POWER IF WATER DROPS BELOW HEAT TRANSFER TUBES.

6. Set thermostat and turn fryer on to bring water to a gentle boil.
 7. Once boil has been reached, turn fryer off.
 8. Dissolve 2/3 cup of Keating Sea Powder for every five gallons of water and let soak for 1/2 hour. If there is a large build-up of carbonized grease, allow fryer to soak overnight.
- CAUTION:** When soaking overnight, make sure the fryer is turned off.
- CAUTION:** Do not damage or reposition thermostat probe as this may affect the accuracy of the fryer.
9. While soaking, a natural fiber brush may be used to scrub the tubes and inside walls of fryer.
 10. Drain the water and Sea Powder into a dry suitable receptacle and remove from cooking area.
- NOTE:** DO NOT pump water through the filter machine.
11. Spread Keating Klenzer liberally on tubes and sides of fryer vessel.

12. A non-abrasive scouring pad may be used to remove the now softened carbonized grease.
13. Thoroughly rinse fryer vessel with potable water to remove all Klenzer.
14. Prior to refilling with oil, wipe the inside of the fryer vessel making sure all water and Klenzer has been removed.

⚠ WARNING

WATER IN ANY FORM AND HOT OIL DON'T MIX!

- 15. Close drain valve.

⚠ WARNING

FAILURE TO CLOSE DRAIN VALVE BEFORE REFILLING THE FRYER MAY RESULT IN SERIOUS INJURY.

- 16. Check thermostat bulb positioning - see page 9.
- 17. Refill the fryer with new oil.

■ MAINTENANCE

WARRANTY REPAIRS

Keating's warranty begins with the date of installation. In the event that your Incredible Frying Machine™, under warranty, needs repairs other than routine maintenance or cleaning, you are required to contact Keating of Chicago (at 1-800-KEATING) before calling a local service company.

PREVENTIVE MAINTENANCE

Preventive maintenance should be done in daily, weekly, monthly and yearly intervals as necessary. Following preventive maintenance procedures will help keep your fryer working efficiently. Proper care and servicing will lead to years of quality performance.

PREVENTATIVE MAINTENANCE CHART

TIME FRAME	OPERATOR/OWNER
AT LEAST DAILY*	<ul style="list-style-type: none"> • Check lights and controls. • Check that the oil is up to "Max Level" line. • Clean all baskets. • Drain, strain or filter oil.
AT LEAST WEEKLY*	<ul style="list-style-type: none"> • Drain and clean fryer. • Boil-out fryer. • Clean blower grease filter.
AT LEAST MONTHLY*	<ul style="list-style-type: none"> • Verify Thermostat settings. • Test Hi-Limit control.
TIME FRAME	QUALIFIED SERVICE PERSONNEL
AT LEAST YEARLY*	<ul style="list-style-type: none"> • Check burner flame color.
EVERY 5 YEARS*	<ul style="list-style-type: none"> • Replace center tube divider.

*High production facilities should be checked more often. Contact the factory or a local service company to perform maintenance and repairs.

Oil Breakdown

As part of a "Preventive Maintenance Program", the oil in your fryer needs to be filtered regularly to avoid breakdown. The initial investment in the frying system is less than the total overall costs of oil during the life of the fryer, and with regular filtering, you can realize substantial savings in oil costs as well as maintenance charges.

LIMITED CALIBRATION

(Less than 25° difference)

You will need:

- One screwdriver with 1/8" wide flat blade
- One accurate fryer thermometer

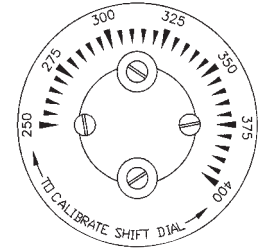

Thermostat knob removed to reveal calibration screws

1. Set thermostat to desired frying temperature.
2. Allow thermostat to cycle three times.
3. Place an accurate thermometer in the oil.
4. If calibration of fryer is found to be less than 25°F off, simply loosen the four retaining screws holding the dial plate in place. Reset the dial plate to match the thermometer reading. If the fryer is found to be more than 25°F off, a qualified service company must be contacted to have the fryer properly calibrated.

⚠ WARNING

DO NOT ADJUST THE THERMOSTAT SET SCREW - IT VOIDS ANY WARRANTY ON PART.

Thermostat Bulb Positioning

BEFORE REPLACING, TEST THERMOSTATS

NOTE: Operational problems can easily be corrected by thermostat bulb positioning.

Keating's patented thermostat application is accurate within 2°F of the dial setting between 250°F – 350°F. This accuracy is attained only if the thermostat bulb is placed properly against the heat transfer tube. To quickly and accurately test for proper bulb placement, a single thickness of writing paper should be pulled through between the tube and the bulb with medium resistance.*

1. *For 14" IFM Fryers:

- The end of thermostat bulb should touch the burner tube.

1. For 18" & 20" IFM Fryers:

- If the bulb is too loose, the paper will slip through with little or no resistance. A fryer with a thermostat bulb that is too loose will overshoot.

Overshoot: The thermostat takes a long time to cycle and then misses its preset temperature by 20°F - 40°F yielding a poor quality product. overshoot.

- If the bulb is too tight, the paper will either not pull through or it will tear. A fryer with a thermostat bulb that is too tight will short cycle.

Short Cycle: The thermostat will cycle rapidly while the fryer is in the idle mode; the temperature will be erratic.

Figure 8
18" & 20" IFM
Thermostat bulb
positioning

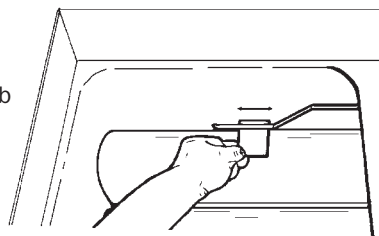

- bright red/orange with proper mixture - orange "glow" around burner tube.
- too much gas – orange "haze" around burner tube (showing incomplete combustion)
- too little gas – blue at front of burner, or totally blue

Remove the cover by loosening the screws to gain access to the burner viewing windows. (14 IFM shown).

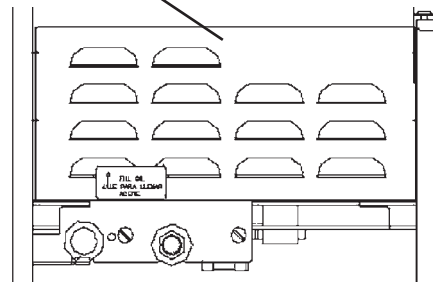

REQUIRED TEST THERMOSTAT

Multimeter (for testing continuity)

CHECKING CONTINUITY WITH THE MULTIMETER

1. Rotate the thermostat shaft until an audible click is heard.
2. Rotate the thermostat shaft left and right ten times causing the switch to click on and off ten times, while using the Multimeter to verify continuity.
3. If the switch does not show continuity during all ten trials, replace the thermostat.

CAUTION

Disassembling the thermostat will void the thermostat warranty.

1. Set compression ring onto capillary end of bulb finger tight, 1/2" from end of capillary.
2. Insert new thermostat bulb through control panel back.
3. Apply oil resistant flexible sealant on to compression fitting thread before installing fitting into fryer vessel.
4. Position bent portion of bulb against far right heat transfer tube and install compression fitting snugly into fryer vessel.
5. Adjust bulb so at least 2" of bent portion of it is next to heat transfer tube and tighten compression nut onto compression fitting for fryer 18 & up. The end of thermostat bulb should touch the burner tube for 14" fryers.
6. Refill fryer with oil to "fill level line".
7. Start fryer, preheat and calibrate with thermometer.

SERVICE

WARNING

ALL HI-LIMIT CONTROLS ARE PRESET AT THE FACTORY FOR A SPECIFIC TEMPERATURE. DO NOT ATTEMPT TO CHANGE THE SETTING OF THE HI-LIMIT. IF THE HI-LIMIT FAILS TO SHUT OFF BETWEEN 425°F AND 450°F DURING TESTING, IT MUST BE REPLACED.

FLAME ADJUSTMENT

A. Gas Pressure

1. At gas valve, remove adjustment port cover, rotate adjustment screw with screwdriver and replace port cover.
2. To check the gas pressure (3" WC for natural gas or 10" WC for Propane at the manifold), use an allen wrench to remove the gas pressure test port, located in the center of the manifold.
3. Line pressure (incoming pressure) is critical for proper ignition of the IFM. Incoming pressure must be:

Natural - 7" W.C.

Propane - 11" W.C.

B. Air Flow

1. To determine the proper gas/air mixture, look into the viewing window for each burner, located just to the left of each burner air hose where the hose is connected to the burner assembly. **(See Figure 8).**

■ SELF HELP GUIDE

A properly adjusted Keating Incredible Frying Machine™, with no load, will cycle “on” approximately every 2-1/2 to 3 minutes. Each cycle will last 15-25 seconds, ensuring that the temperature setting is held within a narrow band.

- Every Keating Incredible Frying Machine™ (IFM) has a number of safety controls to ensure safe operation and guard against component failure.

NOTE: To correctly and quickly diagnose the system, the chart below should be followed in sequential order.

PROBLEM	PROBABLE CAUSE	SOLUTION
No power to unit a. Power switch light ON only b. Power Switch light and Red overmax temperature light on c. All lights are off	a. Drain handle not locked into place. b. High limit light has been activated. c. Breaker has tripped.	a. Locate the handle used to drain oil from fryer. Pull handle up and push it in as far as possible, locking it into place and activating the safety switch b. Reset the high-limit (press the red button located in the bottom of the control panel). c. Reset the breaker located on the bottom of the control panel, check the outlet or check the breaker at the wall.
Timers (or lights) ON but fryer does not try to light	a. Thermostat off.	a. Set the thermostat to desired temperature.
Blower light on. Red burner light comes on and goes out after about 10 seconds	a. Problem with the outlet at the wall. b. Gas not turned on or not hooked up.	a. Plug fryer in to a different electrical outlet (must be properly grounded). b. Ensure gas hose is securely connected. Turn on main gas.
Not recovering	a. Gas pressure incorrect. b. Thermostat not calibrated. c. Overloading fryer.	a. Contact service agent to verify proper gas pressure. b. Calibrate the thermostat by rotating the dial plate to match the actual temperature of the oil (See page 9). c. Do not overfill baskets with food. Do not overfill fryer with oil (check the fill level stamped into the fry pot).

■ SERVICE DIAGNOSIS

The following diagnosis is only to be used as a guide to qualified service personnel. Keating recommends that you use a qualified & licensed service company. (Equipment still under warranty requires it.) Call 1-800-KEATING if you need assistance in locating a qualified service company.

NOTE: To correctly and quickly diagnose the system, the chart below should be followed in sequential order.

TROUBLE SHOOTING CHART

PROBLEM	PROBABLE CAUSE	SOLUTION
Main power light does not come on	<ul style="list-style-type: none"> a. Fryer not plugged in. b. Breaker has tripped. c. Main power switch is faulty. 	<ul style="list-style-type: none"> a. Plug fryer to an approved outlet. Must be properly grounded. b. Reset the breaker located on the bottom of the control panel. c. Replace the main power switch.
Blower light does not come on	<ul style="list-style-type: none"> a. Thermostat not turned on. b. If blower comes on, blower light is faulty. c. If Over Maximum Temperature light is on, Hi-Limit has been activated. d. If unit has a filter, drain handle not locked into place. 	<ul style="list-style-type: none"> a. Set thermostat to desired temperature. b. Replace blower light. c. Reset Hi-Limit after oil has cooled down below 425°F. Correct problem which caused Hi-Limit to activate. (See page 16). d. Secure drain handle in place behind the bracket.
Burner light does not come on	<ul style="list-style-type: none"> • <i>Check for flame at each burner.</i> <i>If no flame is present at either burner:</i> <ul style="list-style-type: none"> a. Spark module is faulty. • <i>Check for flame at each burner.</i> <i>If flame is present at both burners:</i> <ul style="list-style-type: none"> b. Burner light is faulty. 	<ul style="list-style-type: none"> a. Replace spark module. b. Replace burner light.
Burner light comes on, then goes out (after 2 1/2 seconds)	<ul style="list-style-type: none"> • <i>Check for spark at each burner.</i> <i>If no spark at either burner:</i> <ul style="list-style-type: none"> a. Spark electrode wires are not tight or faulty. b. Spark electrode is faulty or is out of alignment. • <i>Check for spark at each burner.</i> <i>If spark occurs at both burners:</i> <ul style="list-style-type: none"> c. Gas is not hooked up properly or not turned on. d. Spark electrode is faulty or is out of alignment. e. Gas valve is faulty. 	<ul style="list-style-type: none"> a. Tighten spark electrode wires or replace. b. See detail on page 20. c. Turn manual gas valve on. If using flexible connector with quick disconnect, make sure that the quick disconnect is completely engaged. d. Align spark electrode. Replace spark electrode if faulty. Gap must be 1/8" between electrode and pilot tube and between pilot tube and burner (See page 20). e. Replace gas valve after verifying it has voltage.

PROBLEM	PROBABLE CAUSE	SOLUTION
Delayed ignition	<ul style="list-style-type: none"> a. Spark electrode gap is incorrect. b. Gas pressure excessive (incoming or manifold). c. Spark module intermittent. 	<ul style="list-style-type: none"> a. Set proper gap on electrode (See detail on Page 26). b. Set pressure to serial plate. c. Replace spark module.
Fryer has poor recovery	<ul style="list-style-type: none"> a. Over-filling baskets. b. Over-filling fryer with oil. c. Thermostat bulb improperly placed. d. Carbon coating on heat transfer tubes. e. Low gas pressure or volume. f. Inefficient burner combustion. 	<ul style="list-style-type: none"> a. Don't over-fill baskets. b. Fill fryer up to "Fill Level" line as oil will expand when heated. c. Adjust bulb position. See page 9 – Thermostat Bulb Positioning. d. Boil-out fryer. See page 8 – Cleaning and Boil-out. e. Contact a qualified service person to check gas pressure. f. Adjust gas/air mixture. See page 10 – Flame Adjustment.
Fryer overshoots temperature setting	<ul style="list-style-type: none"> a. Thermostat bulb improperly placed. b. Thermostat out of calibration. 	<ul style="list-style-type: none"> a. Adjust bulb position. See page 9 – Thermostat Bulb Positioning. b. Calibrate thermostat. See page 9 – Calibration.
Oil in fryer vessel smokes	<ul style="list-style-type: none"> a. Oil has begun to break down. b. High carbon content in oil. c. Dirty fryer vessel. d. Inferior grade of oil. e. Fryer is overheating. 	<ul style="list-style-type: none"> a. Replace oil. b. Filter oil completely, replace if necessary. c. Boil-out fryer. See page 8 – Cleaning and Boil-out. d. Check with supplier for the grade of oil you need for your cooking applications. e. Check calibration of thermostat (See page 9) and replace if necessary.
Basket lift mechanism will not operate	<ul style="list-style-type: none"> a. Breaker tripped. b. Connections are loose or electronic timer is faulty. c. Actuator defective. 	<ul style="list-style-type: none"> a. Reset breaker located in rear of fryer, or on bottom of control panel back (Note Basket Lift circuit breaker is labeled). b. Make sure connections are tight. Replace timer if faulty. c. Replace actuator.
Basket-lift motor runs, but basket does not move	<ul style="list-style-type: none"> a. Actuator is faulty. 	<ul style="list-style-type: none"> a. Replace actuator.
Basket(s) rise prematurely	<ul style="list-style-type: none"> a. Electronic timer is faulty. b. Basket lift relay is faulty. 	<ul style="list-style-type: none"> a. Replace timer. b. Replace relay.
Spark module flashing	<ul style="list-style-type: none"> a. Steady OFF. b. Steady ON. c. 2 Flashes. d. 3 Flashes. 	<ul style="list-style-type: none"> a. NO Power or Control Hardware Fault. b. Spark Module internal failure. Replace Spark Module. c. Flame sense with no call for heat. Check thermostat control and wiring. d. Ignition lockout: <ul style="list-style-type: none"> 1. Turn off unit. 2. Check incoming gas. 3. With unit on, check spark at electrode. 4. Check electrode gaps (with unit turned off).

■ ORDERING PARTS

Parts may be ordered by calling 1-800-KEATING or your local Keating service company. We recommend using genuine Keating Replacement Parts - engineered and manufactured specifically to meet exact specifications and requirements for Keating equipment.

Refer to the Keating Gas Fryer Limited Warranty for complete service and ordering information.

The model/serial plate is attached to the inside of the front door. The serial and model numbers are necessary when ordering.

WARNING AND OPERATING PLATES

All warning and operating plates on the Keating Incredible Frying Machine™ should be in place at all times. If plates are damaged or lost, replace them immediately.

INCREDIBLE FRYING MACHINE® GAS FRYER ASSEMBLY FRONT DRAIN

(For reference only)

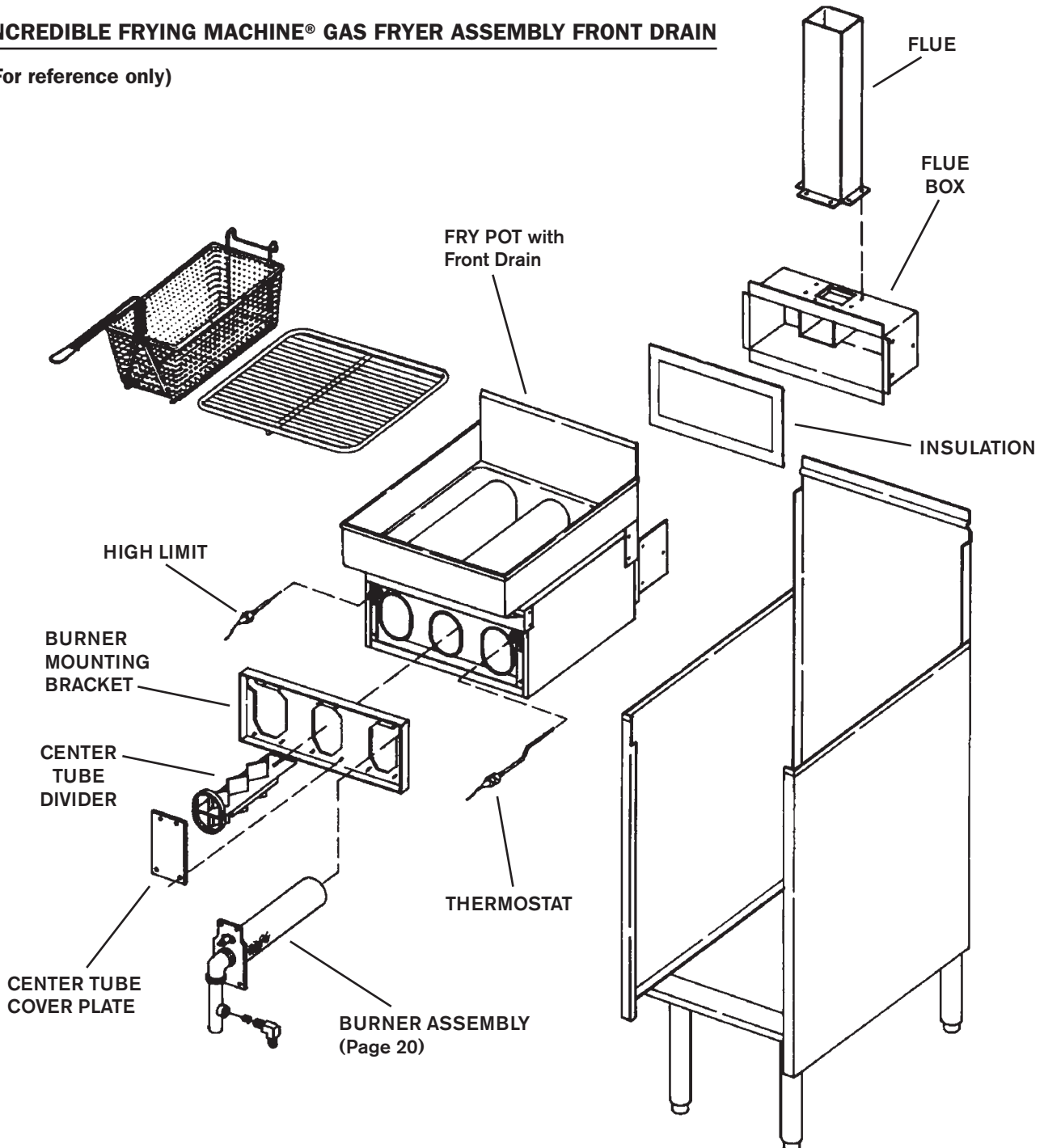

■ PARTS LIST - IFM GAS FRYER

INCREDIBLE FRYING MACHINE™ GAS FRYER FRONT DRAIN - MODEL 2013

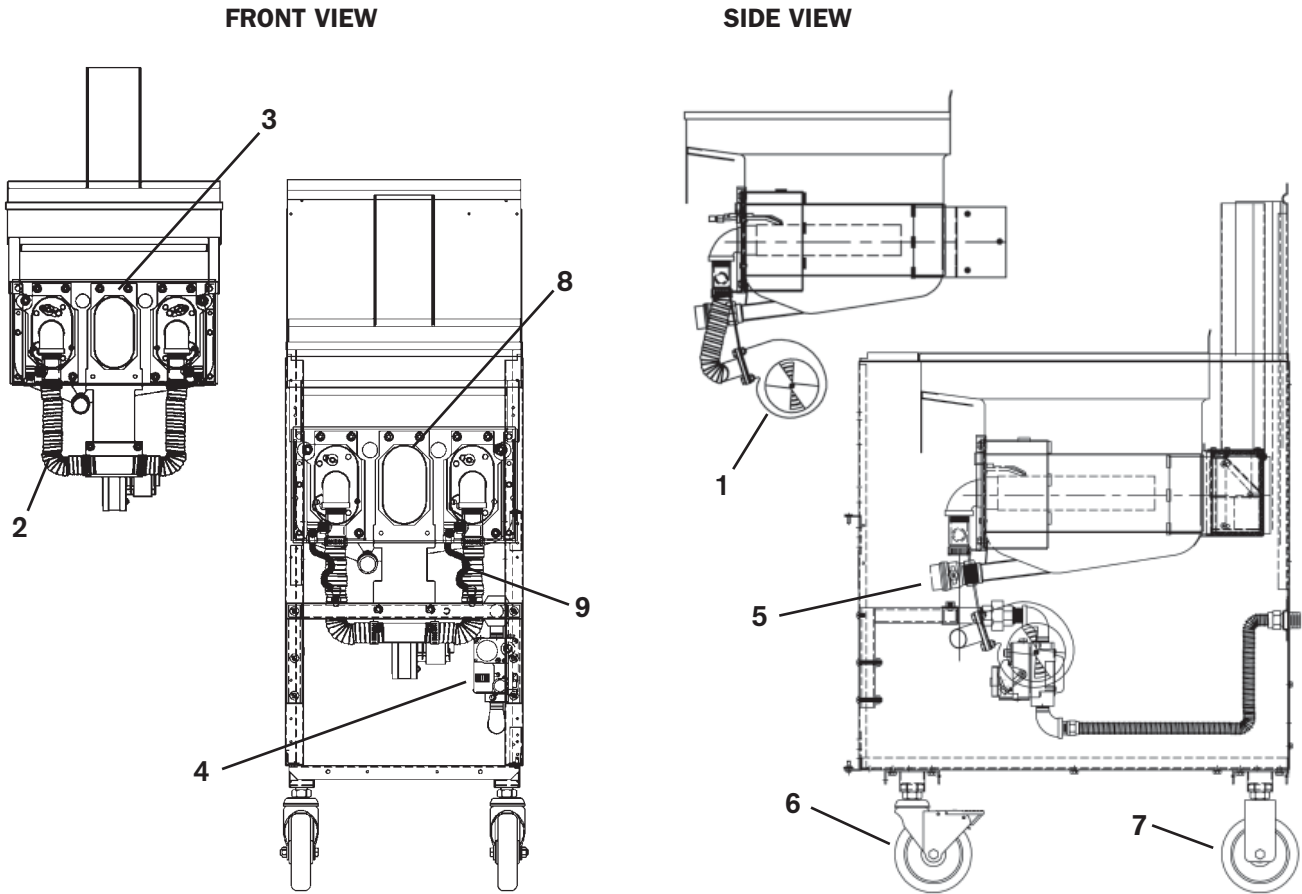

ITEM	MODEL	DESCRIPTION	P/N	QTY
1	14"	BLOWER	030862	1
	18" & 20"	BLOWER	053726	1
2	ALL	AIR HOSE 1.25" ID 8" LONG	057996	2
	ALL	CLAMP 1/2" WIDE BAND 13/16 x 1-1/2"	015393	2
3		FRY POT	1-800-KEATING	1
4	ALL	GAS VALVE - NATURAL GAS	060829	1
	ALL	GAS VALVE - LP	061126	1
5	14"	DRAIN VALVE 1" FRONT	004553	1
	18" & 20"	DRAIN VALVE 1-1/4" FRONT	004554	1
6	ALL	CASTER - SWIVEL, LOCKING	010175	2
	ALL	CASTER - SWIVEL, LOCKING (SE Ready)	037537	2
7	ALL	CASTER - RIGID	011716	2
	ALL	CASTER - RIGID (SE Ready)	037539	2
8	14"	CENTER TUBE DIVIDER BAFFLE ASSEMBLY - 14" MODEL	027338	1
	18"	CENTER TUBE DIVIDER BAFFLE ASSEMBLY - 18" MODEL	027339	2
	20"	CENTER TUBE DIVIDER BAFFLE ASSEMBLY - 20" MODEL	027340	2
9	ALL	FLEX TUBING 3/8" S/S 6" LONG	054512	2

14 IFM CONTROL PANEL ASSEMBLY (FRONT DRAIN WITH TIMERS) - MODEL 2013

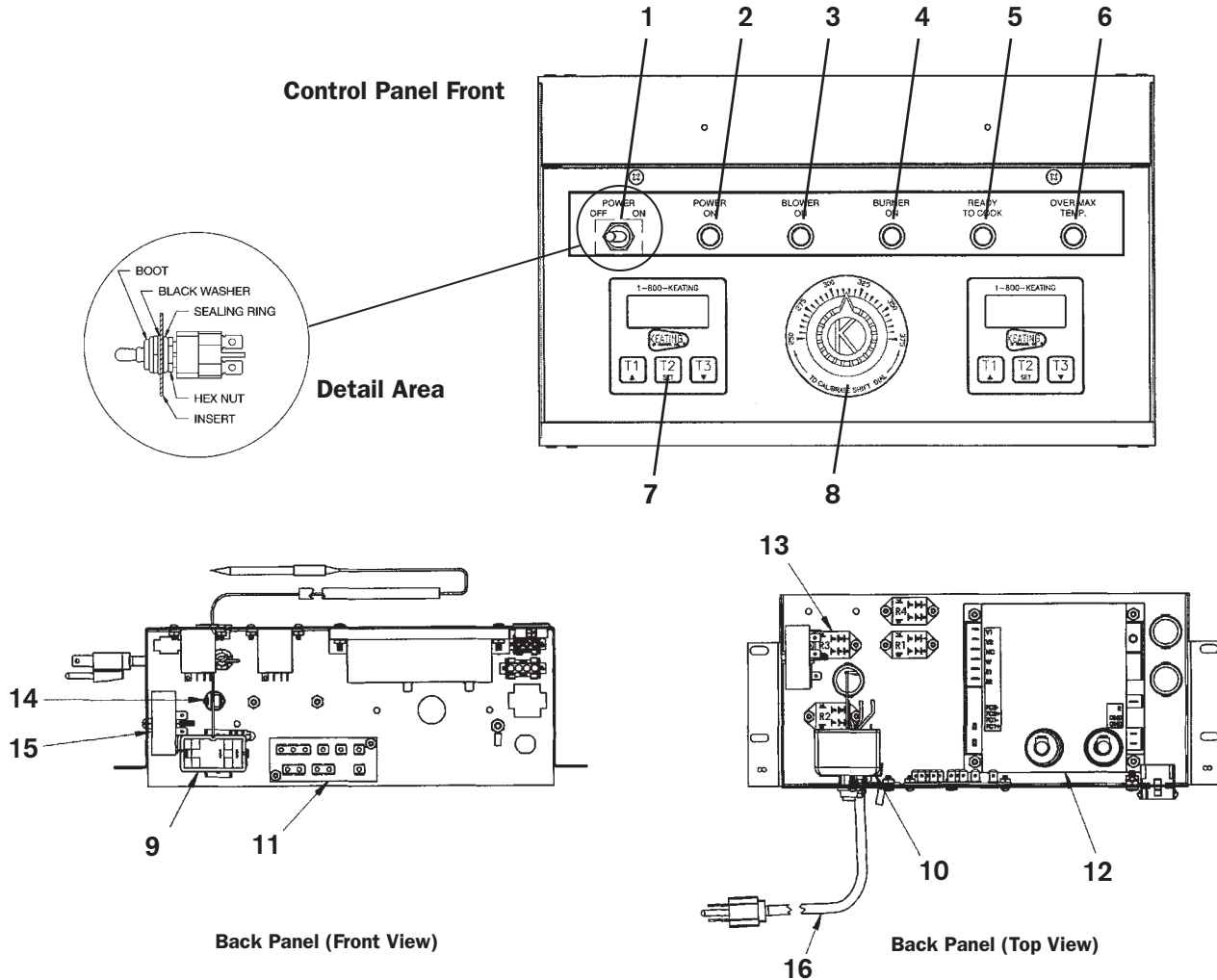

ITEM	DESCRIPTION	P/N	QTY
1	SWITCH TOGGLE SEALED ON-OFF	059141	1
2	INDICATING LIGHT CLEAR ROUND 28V	057863	1
3	INDICATING LIGHT BLUE ROUND 28V	057862	1
4	INDICATING LIGHT AMBER ROUND 28V	056588	1
5	INDICATING LIGHT GREEN ROUND 28V	056587	1
6	INDICATING LIGHT RED ROUND 28V	057861	1
7	TIMER DIGITAL 24/120V	056921	2
8	THERMOSTAT KNOB, BLACK THERMOSTAT DIAL PLATE THERMOSTAT 14IFM	060612 058037 035574	1 1 1
9	HIGH LIMIT MANUAL RESET, NO & NC	032243	1
10*	TRANSFORMER STEPDOWN 24VAC 80VA	024032	1
11	TERMINAL BOARD WITH INSULATION	004153	1
12	SPARK IGNITION MODULE	060826	1
13	RELAY DPDT 24VAC	030844	4
14	CIRCUIT BREAKER, 3 AMP 1 POLE 250V	053338	1
15	RELAY, 35 SECOND DELAY 24VAC	035080	1
16	POWER CORD 9' 120V	006311	1

*Not Shown

14 IFM CONTROL PANEL ASSEMBLY (REAR DRAIN) SAFE & EASY® FILTER - MODEL 2013

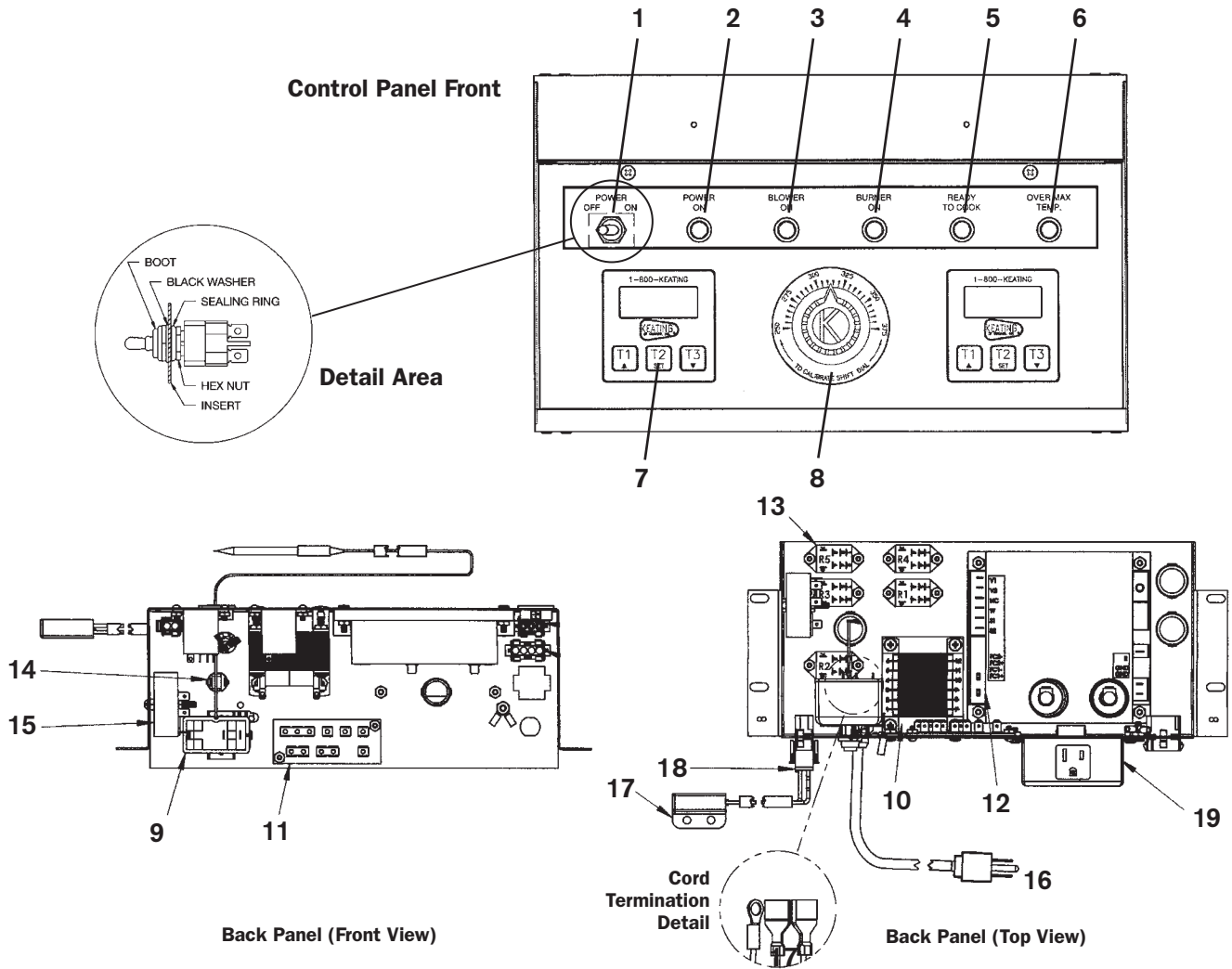

ITEM	DESCRIPTION	P/N	QTY
1	SWITCH TOGGLE SEALED ON-OFF	059141	1
2	INDICATING LIGHT CLEAR ROUND 28V	057863	1
3	INDICATING LIGHT BLUE ROUND 28V	057862	1
4	INDICATING LIGHT AMBER ROUND 28V	056588	1
5	INDICATING LIGHT GREEN ROUND 28V	056587	1
6	INDICATING LIGHT RED ROUND 28V	057861	1
7	TIMER DIGITAL 24/120V	056921	2
8	THERMOSTAT KNOB, BLACK	060612	1
	THERMOSTAT DIAL PLATE	058037	1
	THERMOSTAT 14IFM	035574	1
9	HIGH LIMIT MANUAL RESET, NO & NC	034357	1
10	TRANSFORMER STEPDOWN 24VAC 80VA	024032	1
11	TERMINAL BOARD WITH INSULATION	004153	1
12	SPARK IGNITION MODULE	060826	1
13	RELAY DPDT 24VAC	030844	4
14	CIRCUIT BREAKER, 3 AMP 1 POLE 250V	053338	1
15	RELAY, 35 SECOND DELAY 24VAC	035080	1
16	POWER CORD 9' 120V	006311	1
17	SWITCH, MAGNETIC SAFETY	053777	1
18	CONNECTOR, 2 CIRCUIT QUICK PLUG	032208	1
19	RECEPTACLE 120V COVER SE	052632	1

18 IFM CONTROL PANEL ASSEMBLY (FRONT DRAIN) DUAL POINT SPARK IGNITION - MODEL 2013

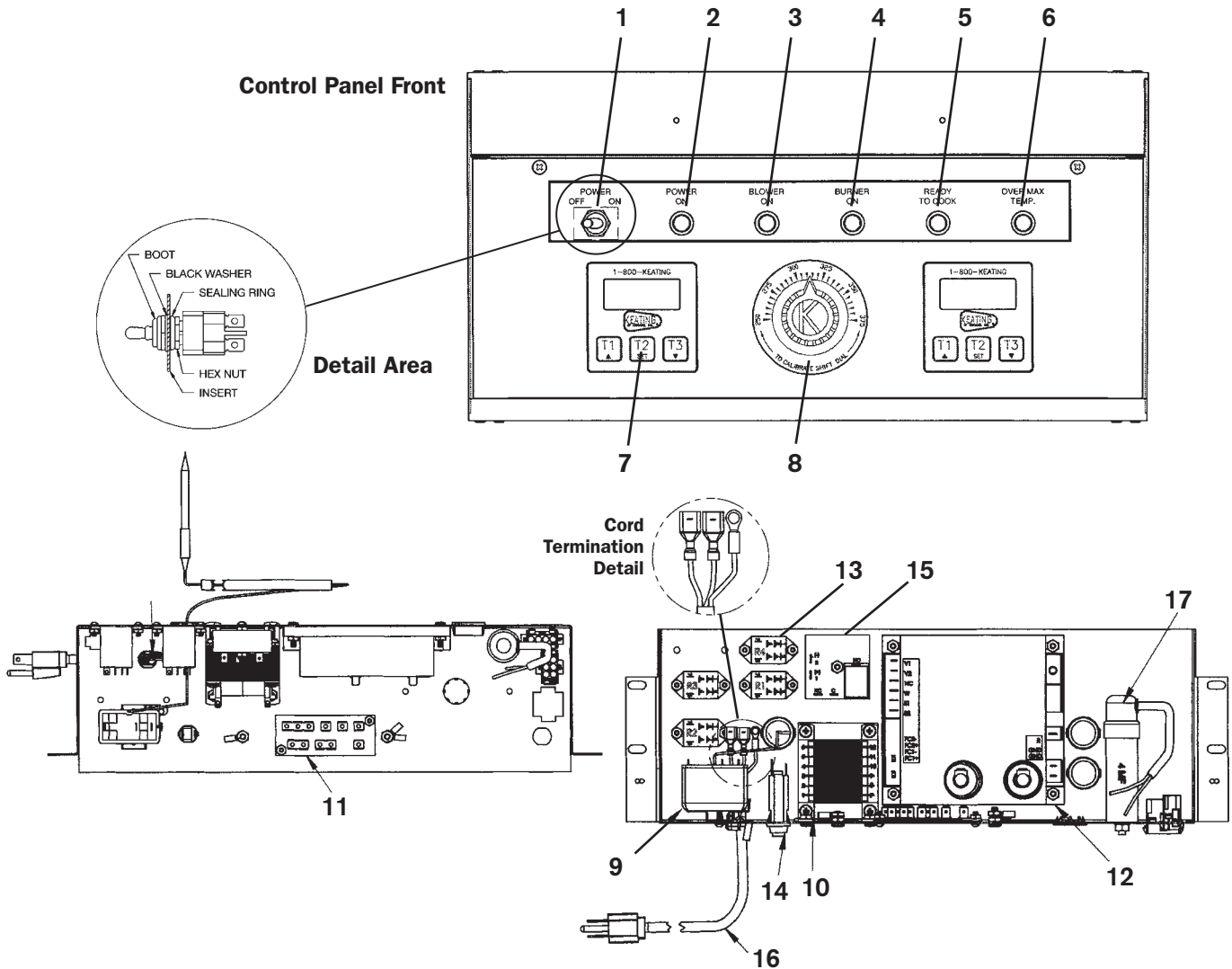

ITEM	DESCRIPTION	P/N	QTY
1	SWITCH TOGGLE SEALED ON-OFF	059141	1
2	INDICATING LIGHT CLEAR ROUND 28V	057863	1
3	INDICATING LIGHT BLUE ROUND 28V	057862	1
4	INDICATING LIGHT AMBER ROUND 28V	056588	1
5	INDICATING LIGHT GREEN ROUND 28V	056587	1
6	INDICATING LIGHT RED ROUND 28V	057861	1
7	TIMER DIGITAL 24/120V	056921	2
8	THERMOSTAT KNOB, BLACK	060612	1
	THERMOSTAT DIAL PLATE 375°F	058037	1
	THERMOSTAT 18 & 20IFM	035575	1
9	HIGH LIMIT MANUAL RESET, NO & NC	032243	1
10	TRANSFORMER STEPDOWN 24VAC 80VA	024032	1
11	TERMINAL BOARD WITH INSULATION	004153	1
12	SPARK IGNITION MODULE	060826	1
13	RELAY DPDT 24VAC	030844	4
14	CIRCUIT BREAKER, 3 AMP 1 POLE 250V	053338	1
15	RELAY, 35 SECOND DELAY 24VAC	035080	1
16	POWER CORD 9' 120V	006311	1
17	CAPACITOR, 4MFD, IFM BLOWER 053646	053990	1

18 IFM CONTROL PANEL ASSEMBLY (REAR DRAIN) SAFE & EASY® FILTER - MODEL 2013

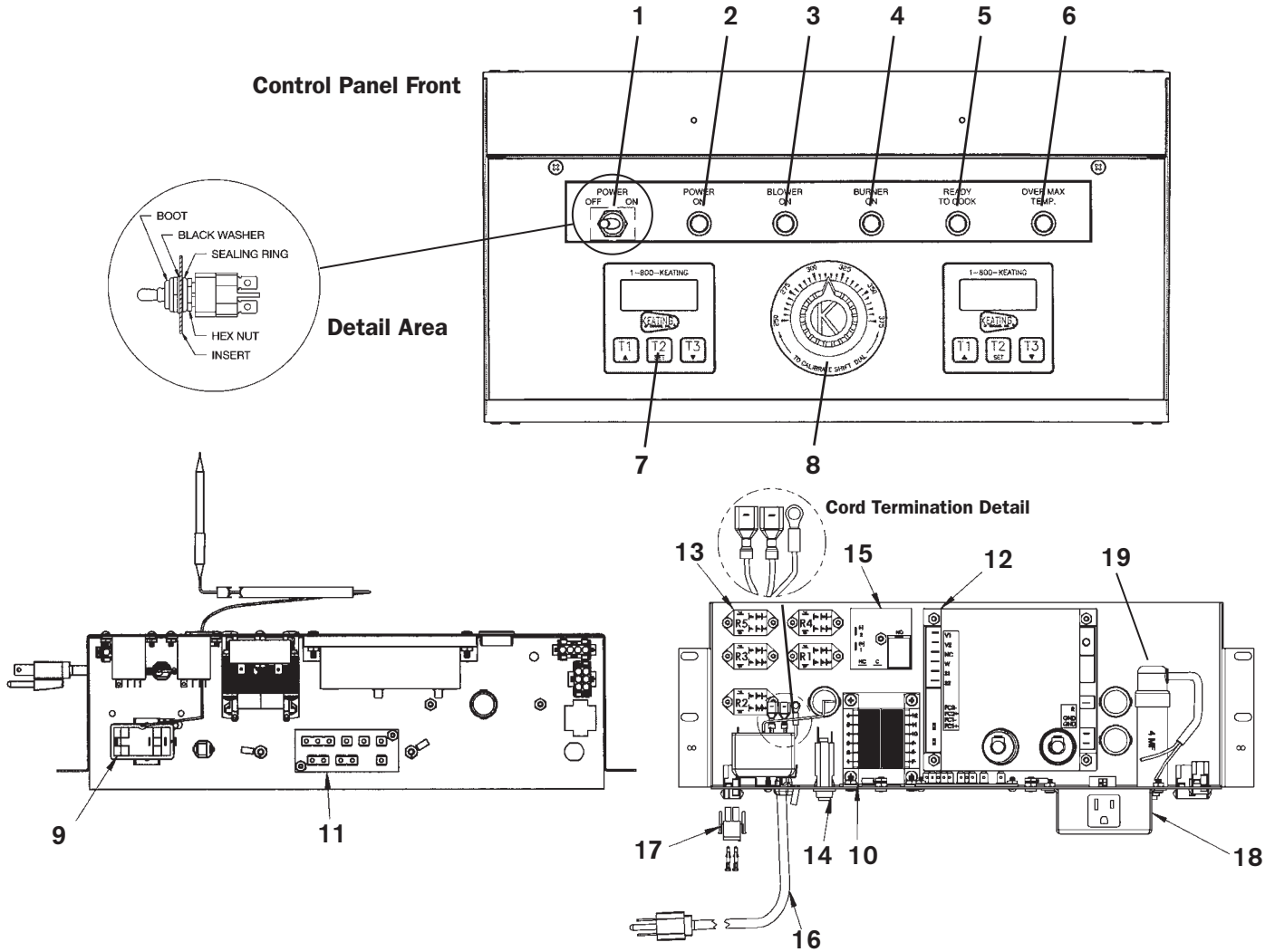

ITEM	DESCRIPTION	P/N	QTY
1	SWITCH TOGGLE SEALED ON-OFF	059141	1
2	INDICATING LIGHT CLEAR ROUND 28V	057863	1
3	INDICATING LIGHT BLUE ROUND 28V	057862	1
4	INDICATING LIGHT AMBER ROUND 28V	056588	1
5	INDICATING LIGHT GREEN ROUND 28V	056587	1
6	INDICATING LIGHT RED ROUND 28V	057861	1
7	TIMER DIGITAL 24/120V	056921	2
8	THERMOSTAT KNOB, BLACK THERMOSTAT DIAL PLATE 375°F THERMOSTAT 18 & 20IFM	060612 058037 035575	1 1 1
9	HIGH LIMIT MANUAL RESET, NO & NC	037406	1
10	TRANSFORMER STEPDOWN 24VAC 80VA	024032	1
11	TERMINAL BOARD WITH INSULATION	004153	1
12	SPARK IGNITION MODULE	060826	1
13	RELAY DPDT 24VAC	030844	4
14	CIRCUIT BREAKER, 3 AMP 1 POLE 250V	053338	1
15	RELAY, 35 SECOND DELAY 24VAC	035080	1
16	POWER CORD 9' 120V	006311	1
17	CONNECTOR, 2 CIRCUIT QUICK PLUG	032208	1
18	RECEPTACLE 120V COVER SE	052632	1
19	CAPACITOR 4MFD	053990	1

IFM BURNER ASSEMBLY - MODEL 2013

Critical Dimensions for Proper Spark Ignitor Gap:

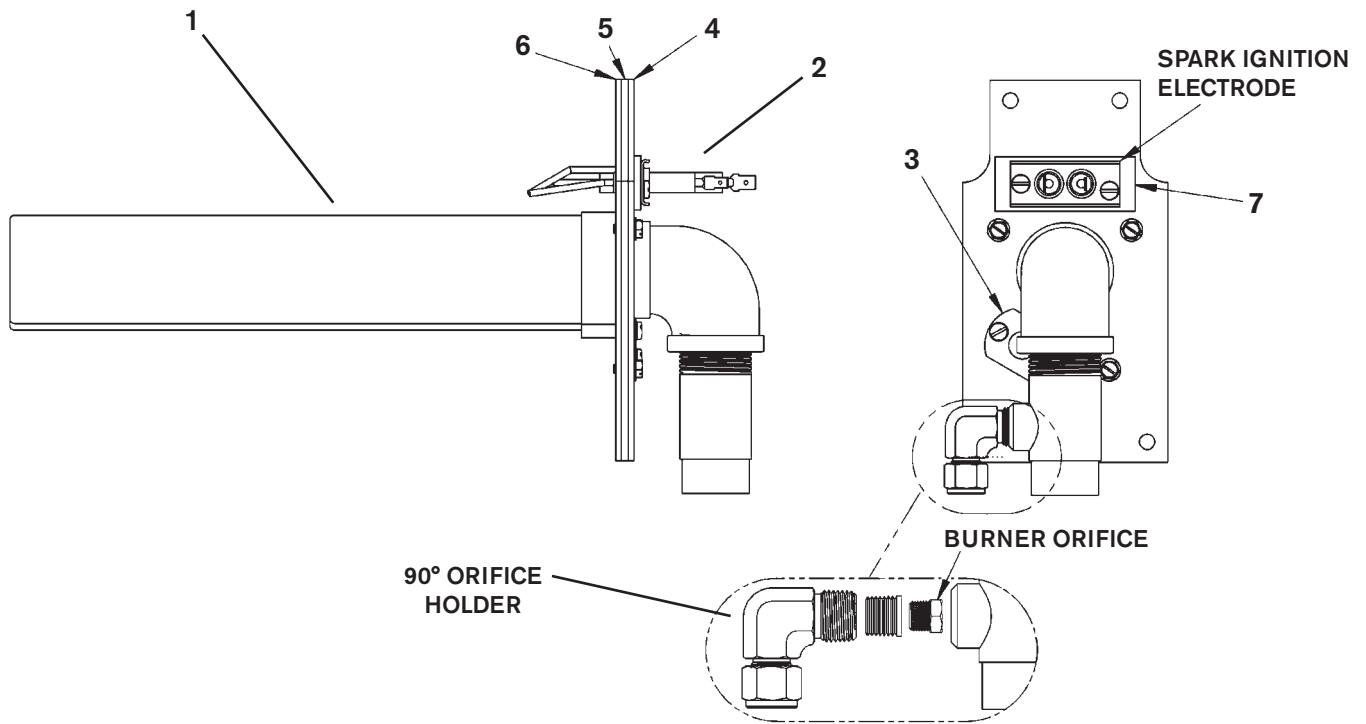
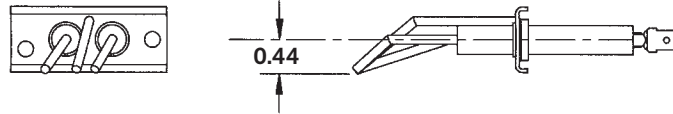
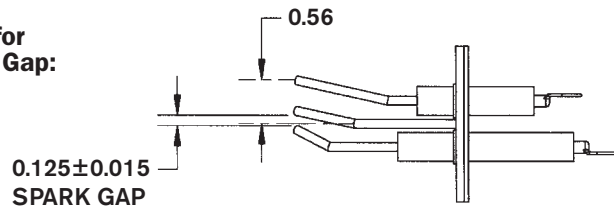

ITEM	MODEL	DESCRIPTION	P/N	QTY
1	14"	BURNER REPLACEMENT KIT	061128	1
	18" & 20"	BURNER REPLACEMENT KIT	061129	1
2	ALL	SPARK ELECTRODE REPLACEMENT KIT		
		NATURAL GAS	060827	1
		LP	060827	1
3	ALL	OBSERVATION WINDOW ASSEMBLY		
		LENS	016101	1
		COVER	015905	1
4	ALL	BURNER OUTER PLATE & ELBOW ASSEMBLY (LEFT OR RIGHT SIDE)	060784	1
5	ALL	BURNER TO PLATE SEALING GASKET	060788	1
6	ALL	BURNER TO TUBE SEALING GASKET	060789	2
7	ALL	GASKET IFM ELECTRODE 060827	061181	2

BASKET LIFT POWER SUPPLY BOX & BASKET LIFT ASSEMBLY

(not shown to scale)

Figure 14

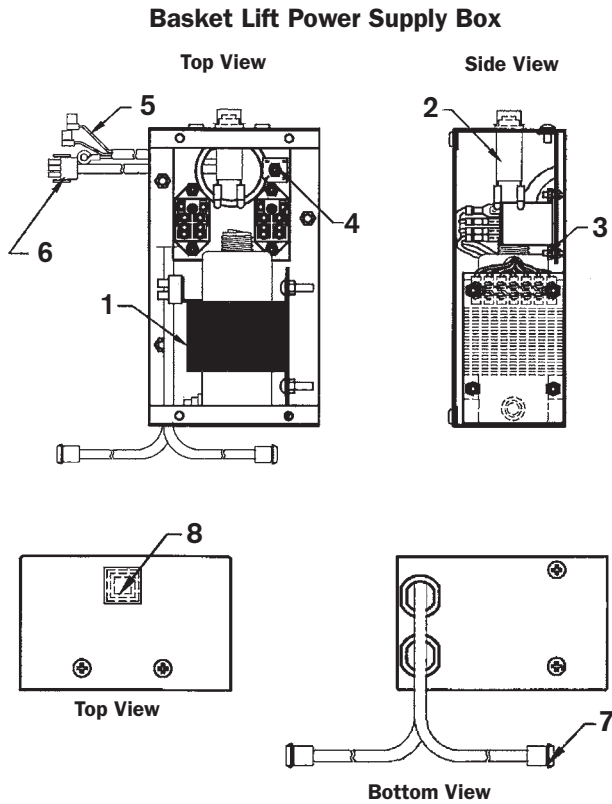
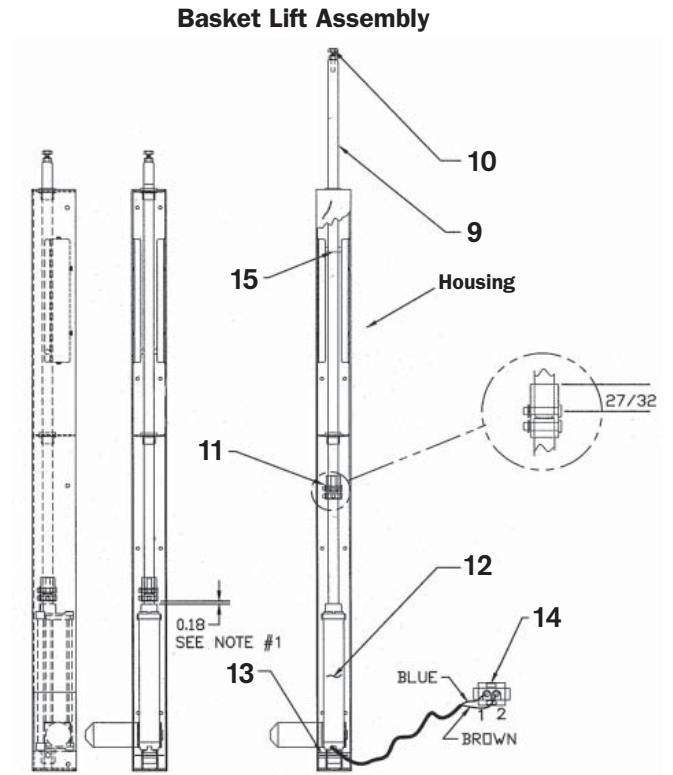

Figure 15



- NOTES:**
1. A minimum distance of 3/16" and maximum distance of 1/4" should be maintained when actuator is at full downward stroke. Item 11 should never be bottomed on item 12 when in this location.
 2. Actuator shaft should travel 6 1/2" upward from lowest position.
 3. Distance is to be measured when actuator is powered.
 4. Apply light coating of food grade grease to Item 9 on entire shaft inside housing.

ITEM	DESCRIPTION	P/N	QTY
1	TRANSFORMER 120/208/240/480V	056036	1
2*	CIRCUIT BREAKER 3A/250V	053338	1
3	RELAY DPDT 24V AC	030844	2
4	RECTIFIER	038367	1
5	POWER CORD	021289	1
6	CONNECTION 3 CIRCUITS PLUG	032210	1
	CONNECTOR CONTACT PIN MALE	028309	3
7	CONNECTOR 2 CIRCUIT CAP	032207	2
	CONNECTOR CONTACT PIN FEMALE	028308	2
8	COVER FOR CIRCUIT BREAKER	054664	1
9	PUSH ROD	018096	1
10	SCREW 1/4"-20" X 1 1/4"	021091	1
	HEX NUT 1/4-20	016383	1
11	COUPLER ACTUATOR BL	054525	1
	RETAINING RING	054540	2
	PIN COUPLER ACTUATOR BL	054503	2
12	ACTUATOR 24V DC	054510	1
13	SHAFT ACTUATOR LOWER BL S/S	054522	1
14	CONNECTOR 2 CIRCUIT PLUG	032208	1
	CONNECTOR CONTACT PIN MALE	028309	2
15	PIN BASKET LIFT NON ROTATIONAL	054760	1

*This circuit breaker can be found under the control panel on newer units.

■ WIRING DIAGRAMS

SINGLE BASKET LIFT POWER SUPPLY BOX

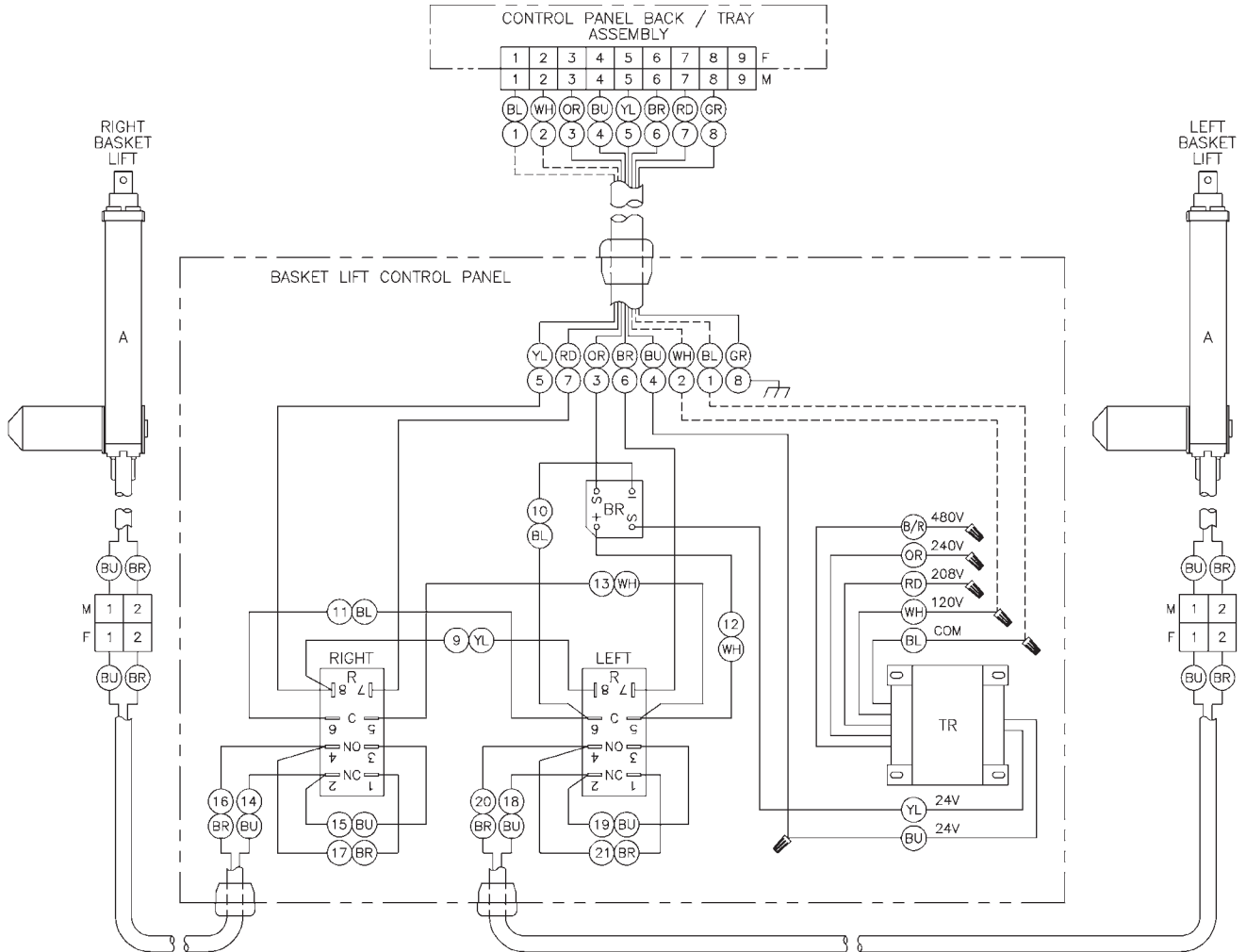

WIRE COLOR CODES:

BL - BLACK
 BR - BROWN
 B/R - BLACK/RED
 BU - BLUE
 GR - GREEN
 OR - ORANGE
 RD - RED
 WH - WHITE
 YL - YELLOW

COMPONENT CODES:

A - ACTUATOR
 BR - BRIDGE RECTIFIER
 R - RELAY 24VAC
 TR - TRANSFORMER (100VA)

NOTES:

ALL WIRES ARE 18 AWG
 120 VAC ---
 24 VAC —

NOTES:

1. Wire Material: See wires specification.
2. Remove 3/8" of insulation from end of wire.



3. Route all wires so they lay flat and are organized in appearance.
4. Tug test all wires connected to terminal board to ensure they are properly secured. Tug test all crimp on connectors in the same fashion.

14 IFM FRONT DRAIN UNIT - MODEL 2013

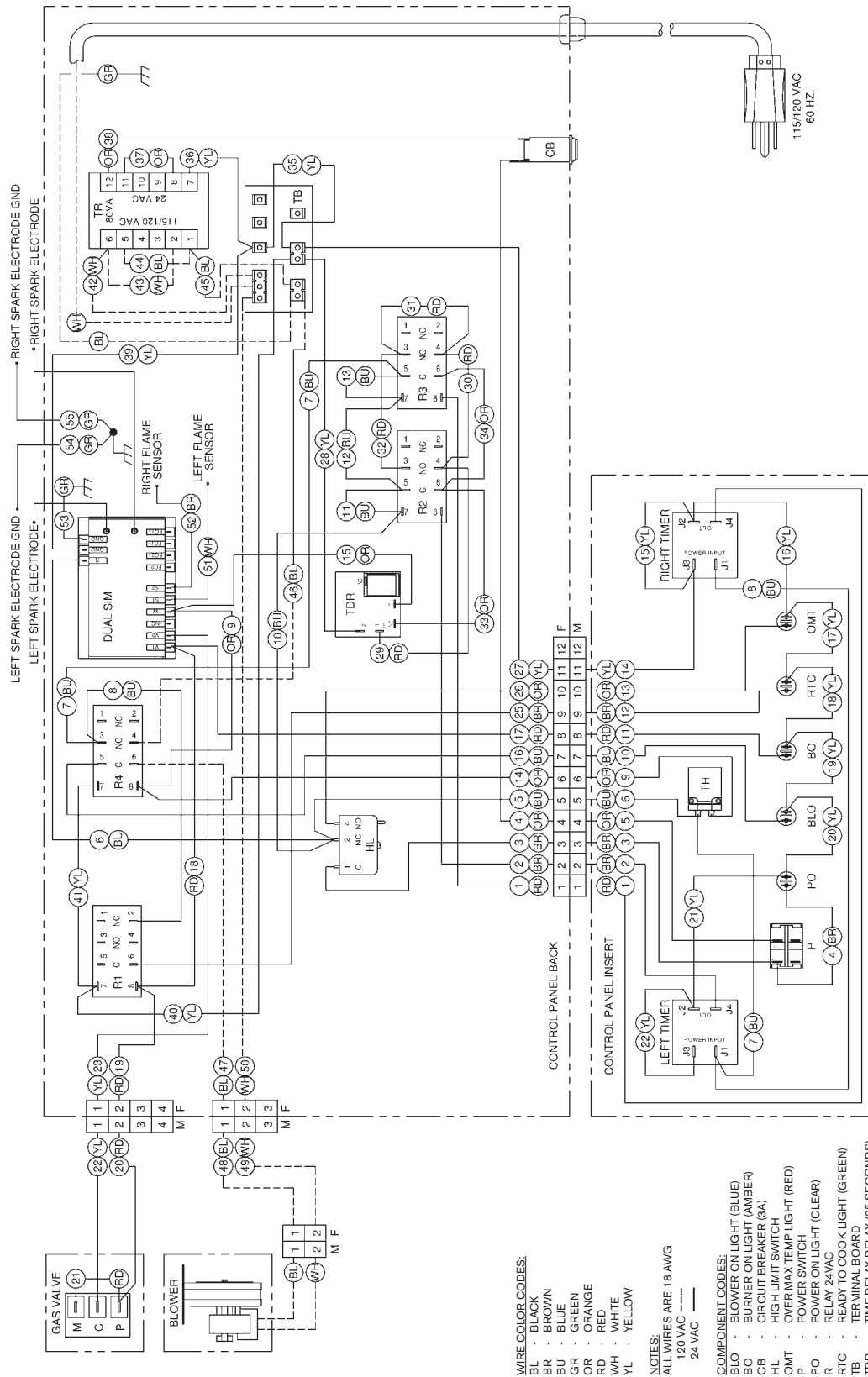

14 IFM REAR DRAIN UNIT - MODEL 2013

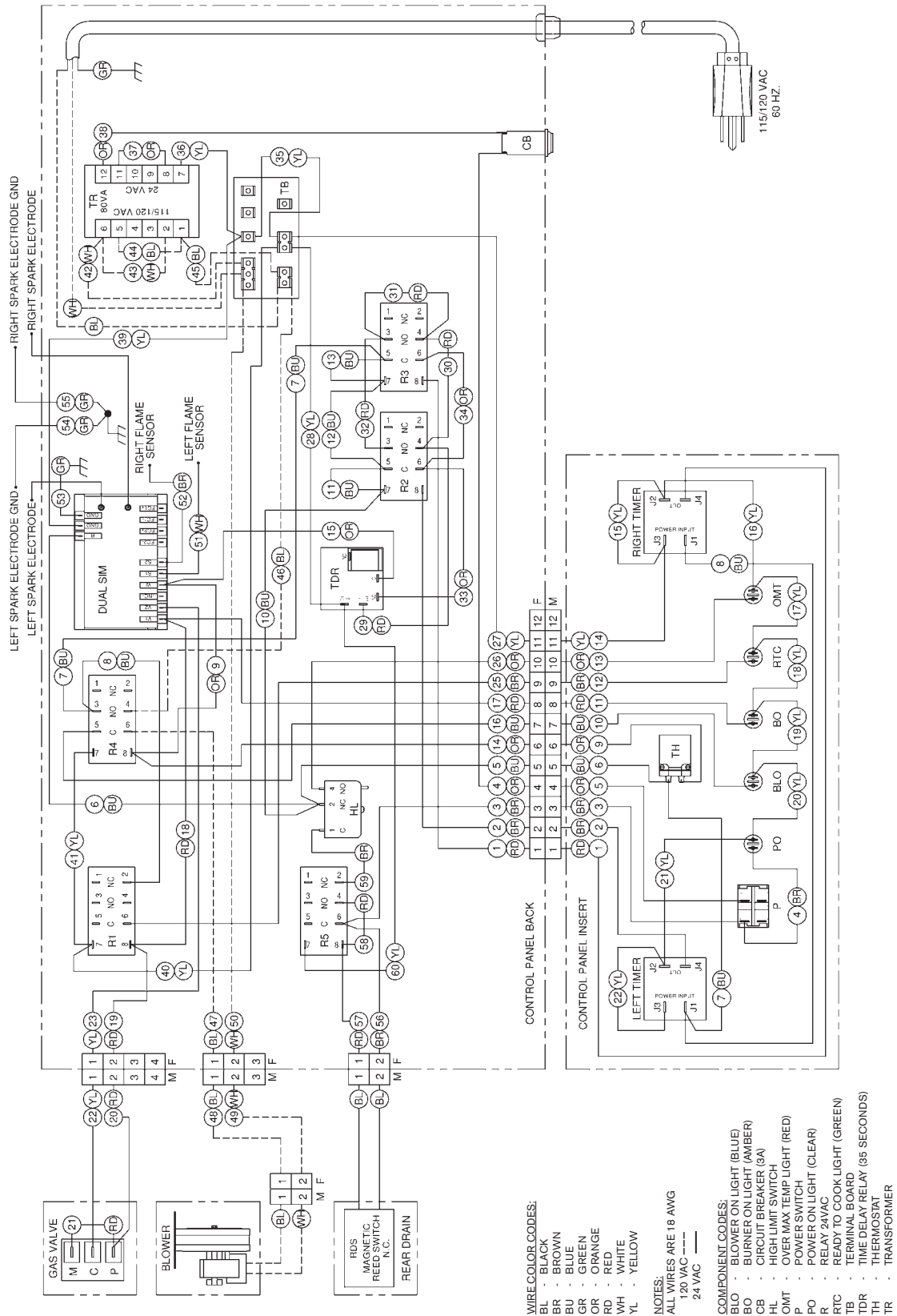

14 IFM REAR DRAIN SAFE & EASY® with BASKET LIFT - MODEL 2013

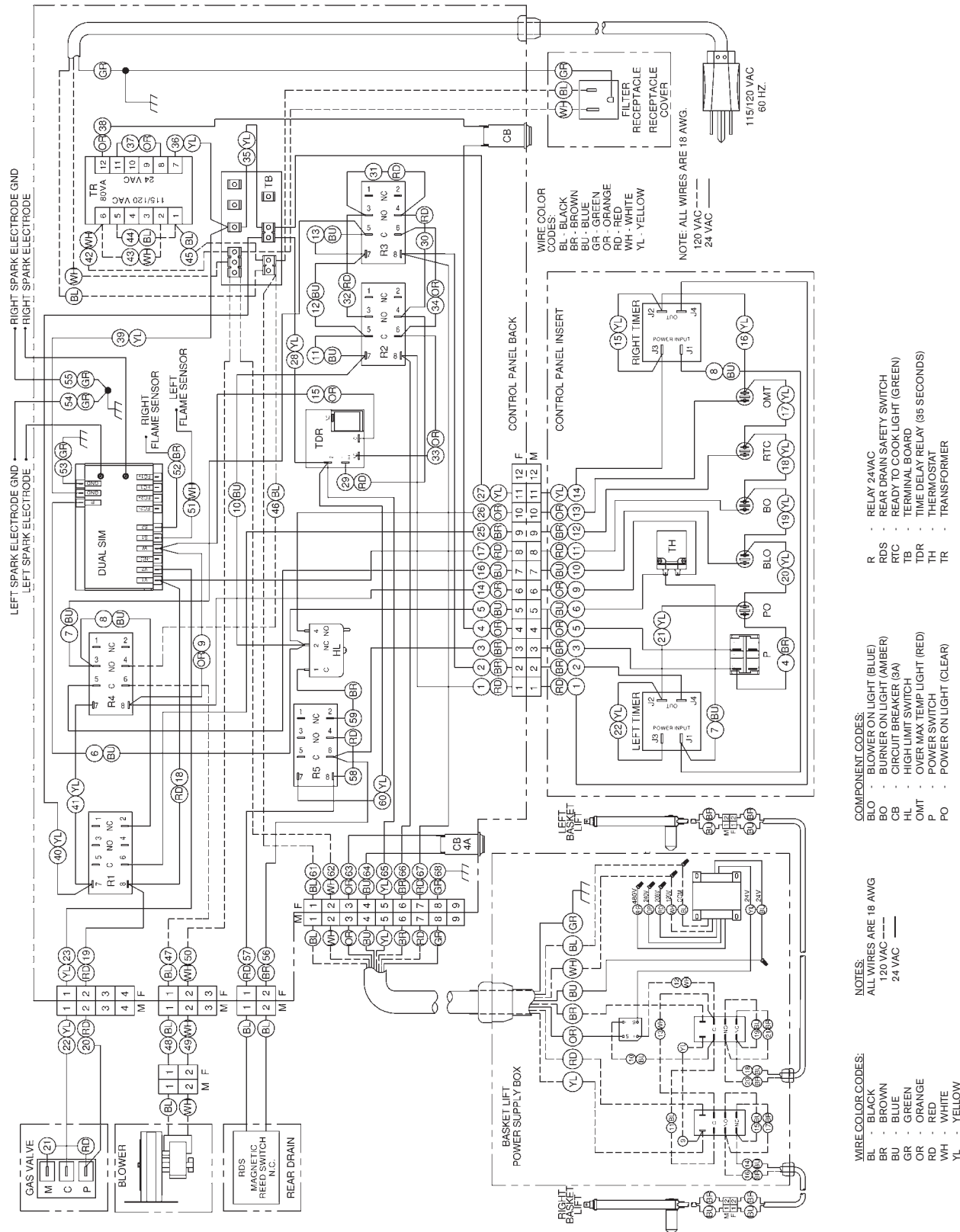

18 & 20 IFM FRONT DRAIN UNITS with DUAL POINT SPARK MODULE - MODEL 2013

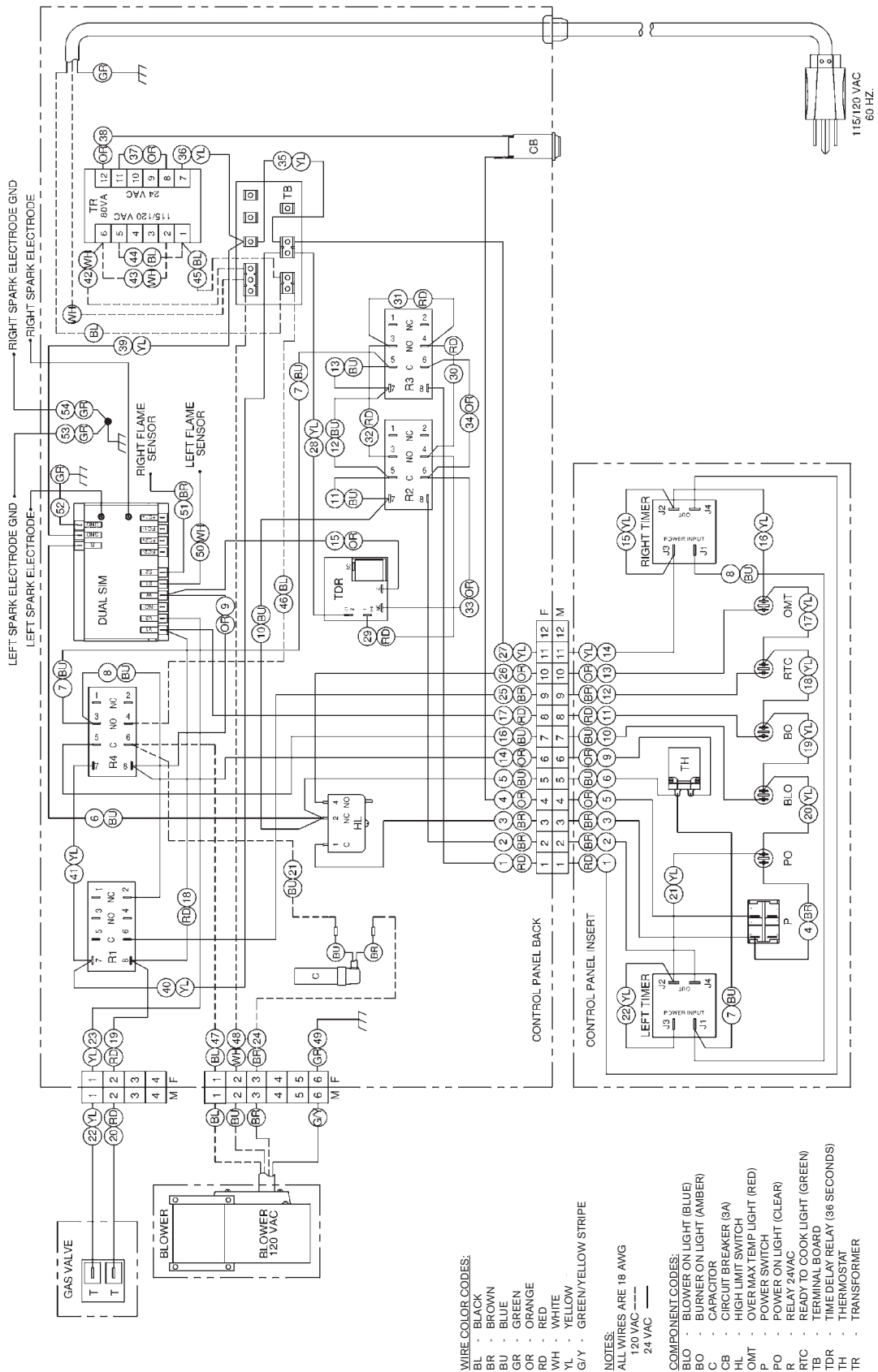

18 & 20 IFM REAR DRAIN SAFE & EASY® FILTER with DUAL POINT SPARK MODULE - MODEL 2013

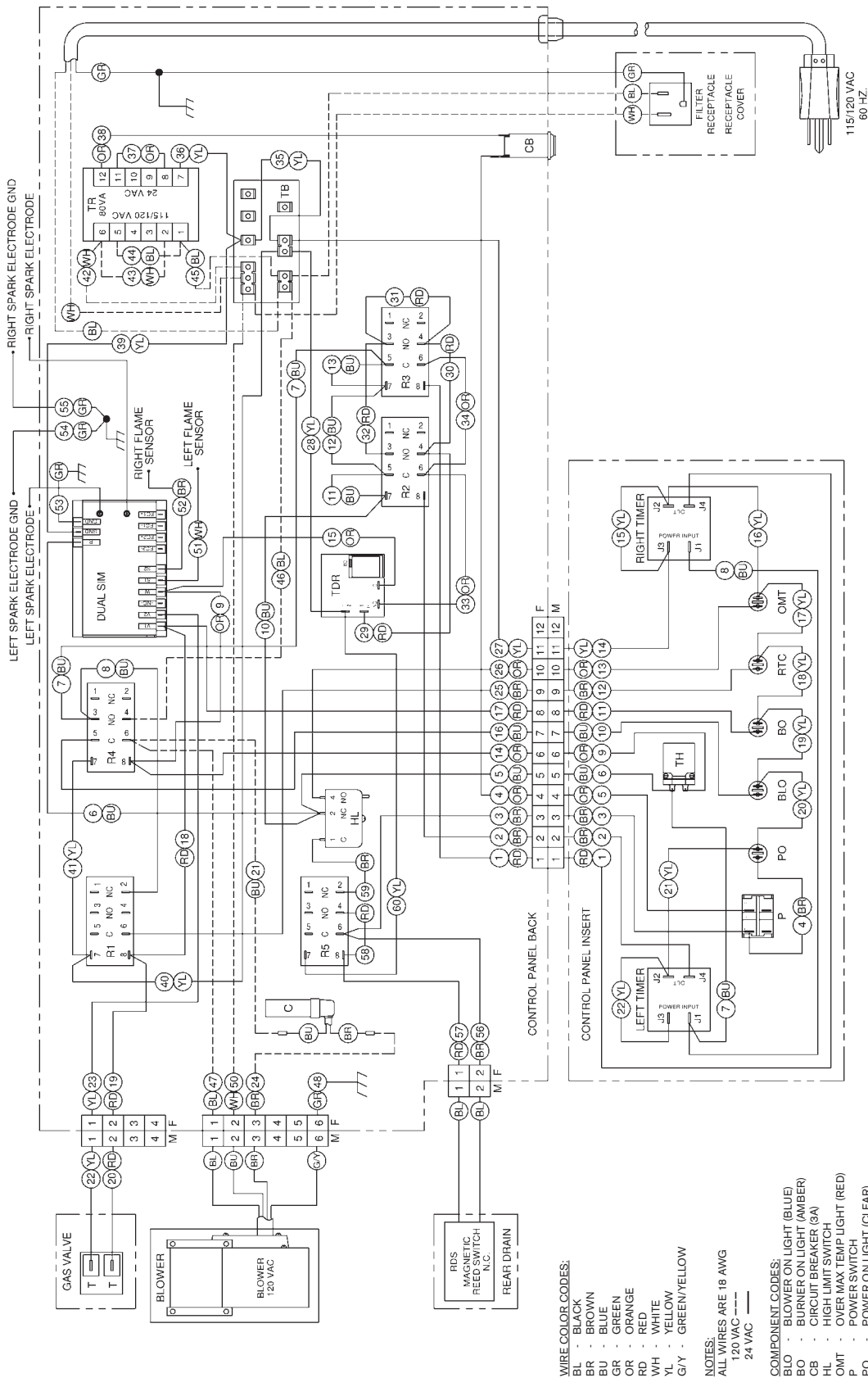

WIRE COLOR CODES:

- BL - BLACK
- BR - BROWN
- BU - BLUE
- GR - GREEN
- OR - ORANGE
- RD - RED
- WH - WHITE
- YL - YELLOW
- G/Y - GREEN/YELLOW

NOTES:

- ALL WIRES ARE 18 AWG
- 120 VAC ---
- 24 VAC ———

COMPONENT CODES:

- BLO - BLOWER ON LIGHT (BLUE)
- BO - BURNER ON LIGHT (AMBER)
- CB - CIRCUIT BREAKER (3A)
- HL - HIGH LIMIT SWITCH
- OMT - OVER MAX TEMP LIGHT (RED)
- P - POWER SWITCH
- PO - POWER ON LIGHT (CLEAR)
- R - READY TO COOK LIGHT (GREEN)
- RTC - READY TO COOK LIGHT (GREEN)
- TB - TERMINAL BOARD
- TDR - TIME DELAY RELAY (35 SECONDS)
- TH - THERMOSTAT
- TR - TRANSFORMER



WARRANTY

LIMITED WARRANTY

Keating of Chicago, Inc. ("Keating") warrants to the original purchaser, ("Customer"), all new Keating Fryers, Filter Systems, Griddles, Keep Krisp[®], Custom Pasta Systems, Top-Side[™] Cookers, Computer Timers, Fryer & Pasta Vessels and Keating replacement parts ("products") installed after June 1, 1994 to be free to defects in material or workmanship, subject to the following terms and conditions.

LENGTH OF WARRANTY

All products other than Fryer & Pasta Vessels and replacement parts shall be warranted for a period of one year from the date of original equipment installation. Keating replacement parts are warranted for a period of ninety days from the date of installation. Fryer & Pasta Vessels are warranted as described below.

FRYER & PASTA VESSEL WARRANTY

Fryers purchased after June 1, 1994 carry a prorated vessel warranty on defects in materials or workmanship to the Customer based on the following scale:

Time from Installation Date	Fryer Vessel Warranty Credit
13-60 months	100%
61-72 months	80%
73-84 months	60%
85-96 months	40%
97-108 months	20%
109-120 months	10%

The credit for the defective fryer & pasta vessel shall be applied against the cost of the replacement vessel, utilizing Keating's then current price, upon return of the vessel to Keating only during the first 60 months, subject to the limitations described below.

LIMITATIONS OF LIABILITY

In the event of warranty claim or otherwise, the sole obligation of Keating shall be the repair and / or replacement at the option of Keating of the product or component part thereof. Such repair or replacement shall be at the expense of Keating except that the Customer shall pay the following expenses: all freight and labor expense for Keating replacement parts; for all other products, mileage exceeding 50 miles or travel more than one hour, labor costs of more than one person, overtime rates, truck charges, difference between ground and other mode of transportation, and holiday charges. Any repair or replacement under this Limited Warranty does not constitute an extension of the original warranty for any period for the product or for any component or part thereof. Parts to be replaced under this Limited Warranty will be repaired at the option of Keating with new or functionally operative parts. Keep Krisps and Computer Timers must be returned to Keating for warranty repair or replacement. Field repairs of those items are not authorized.

THE LIABILITY OF KEATING ON ANY CLAIM OF ANY KIND, INCLUDING CLAIMS BASED ON WARRANTY, EXPRESSED OR IMPLIED, CONTRACT, NEGLIGENCE, STRICT LIABILITY OR ANY OTHER THEORIES SHALL BE SOLELY AND EXCLUSIVELY THE REPAIR OR REPLACEMENT OF THE PRODUCT AS STATED HEREIN, AND SUCH LIABILITY SHALL NOT INCLUDE, AND CUSTOMER SPECIFICALLY RENOUNCES ANY RIGHTS TO RECOVER, SPECIAL, INCIDENTAL, CONSEQUENTIAL OR OTHER INJURIES TO PERSONS OR DAMAGE TO PROPERTY, LOSS OF PROFITS OR ANTICIPATED PROFITS, OR LOSS OF USE OF THE PRODUCT.

If any oral statements have been made regarding the Keating products, such statements do not constitute warranties and are not part of the contract sale. This Limited Warranty constitutes the complete, final and exclusive statement with regard to warranties.

THIS LIMITED WARRANTY IS EXCLUSIVE AND IS IN LIEU OF ALL OTHER WARRANTIES WHETHER WRITTEN, ORAL, STATUTORY OR IMPLIED, INCLUDING BUT NOT LIMITED TO ANY WARRANTY OF MERCHANTABILITY OR FITNESS FOR PARTICULAR PURPOSE OR WARRANTY AGAINST LATENT DEFECTS.

EXCLUSIONS

The warranties provided by Keating of Chicago, Inc. do not apply in the following instances:

1. Defects arising out of or resulting from improper installation or maintenance, abuse, misuse, modification or alteration by unauthorized service personnel, or any other condition not attributable to a defect in material or workmanship. Proper installation and maintenance are the responsibility of the installer and Customer, respectively. Proper installation and maintenance procedures are prescribed by the Keating Service Manual.
2. In the event that the product was damaged after leaving the factory due to flood, fire, other acts of God or accident, damaged during shipment should be reported to the carrier and is not the responsibility of Keating.
3. In the event the serial number or rating plate has been removed from the product or altered.
4. On parts which would normally be worn or replaced under normal conditions, including but not limited to electric bulbs, fuses, interior and exterior finishes, gaskets and radiants.
5. With regard to adjustments and calibrations such as leveling, tightening of fasteners or plumbing connections, improper gas pressure or improper electrical supply, the checking of and changes in adjustment and calibrations are the responsibility of the installer. Proper installation procedures are prescribed by the Keating Service Manual.
6. In the event of unauthorized repairs or alterations to the Keating product.
7. With the use of sodium chloride in pasta vessels or harsh chemicals in fryer or pasta vessels.
8. Installation in Household.

OTHER TERMS AND CONDITIONS

The Customer must provide proof of purchase from Keating.

This Limited Warranty is valid in the 50 United States, its territories, and Canada, and is void elsewhere. Keating products are sold for commercial use only. If any Keating product is sold as a component of another product or used as a consumer product, such Keating product is sold As Is without any warranty.

If any provision of this Limited Warranty is held to be unenforceable under the law of any jurisdiction, such provision shall be inapplicable in such jurisdiction, and the remainder of the warranty shall remain unaffected. Further in such event, the maximum exclusion or limitation allowable under applicable law shall be deemed substituted for the unenforceable provision.

This Limited Warranty shall be governed by and construed in accordance with the laws of the State of Illinois.

TO SECURE WARRANTY SERVICE

All repair services under this Limited Warranty must be authorized by Keating or performed at Keating. Authorization may be obtained by calling 1-800-KEATING within the Continental United States, Alaska, Hawaii, Puerto Rico and Canada during normal business hours (8 a.m. through 5 p.m. Central Time, Monday through Friday). When calling, please have the following information available: (1) name, address and telephone number of the Customer; (2) location of product, if different; (3) name, model number and serial number of the product; (4) installation date; and (5) description of defect. Keating will then issue a service authorization work order number to one of its approved independent servicing organizations, or request the product or part be shipped to Keating for repair or replacement, as appropriate. Any defective part subject to a claim under this Limited Warranty must be shipped freight prepaid to Keating for testing and examination. Keating's decision as to the cause and nature of any defect under this Limited Warranty shall be final.

■ **SERVICE INFORMATION:**

If you have a service related question call **1-800-KEATING**.
Please state the nature of the call; it will ensure speaking with the appropriate person.

Have your serial and model number available when ordering parts.

As continuous product improvement occurs, specifications may be changed without notice.

.....
KEATING LIMITED WARRANTY CARD

PLEASE COMPLETE AND MAIL AT ONCE--WARRANTY IS NOT IN EFFECT UNTIL CARD IS RETURNED, OR COMPLETE THE WARRANTY CARD ON OUR WEBSITE FOR YOUR CONVENIENCE.

COMPANY: _____

ADDRESS: _____

CITY: _____ STATE: _____ ZIP CODE: _____

DEALER NAME: _____

DATE OF PURCHASE: _____ INVOICE #: _____

SERIAL #: _____ MODEL: _____

FRYER GRIDDLE CUSTOM PASTA
 FILTER SYSTEM TOP-SIDE COOKER HOTPLATE

I HAVE READ THE INSTALLATION AND OPERATING INSTRUCTIONS.

SIGNED: _____ DATE: _____



KEATING OF CHICAGO, INC.
8901 West 50th Street
McCook, IL 60525-6001

1-800-KEATING
PHONE: 708-246-3000
FAX: 708-246-3100

Serving Those Who Serve the Very Best®