



SERVICE INSTRUCTIONS

1-800-KEATING • keatingofchicago.com

INSTALLATION INSTRUCTIONS FOR SPARK IGNITION MODULE #037981

For IFMs With Spark Ignition Module Mounted on the Control Panel Back

1. Remove the two screws under the control panel and lower it to expose the obsolete spark module (Part # 019724) and relight circuit components.

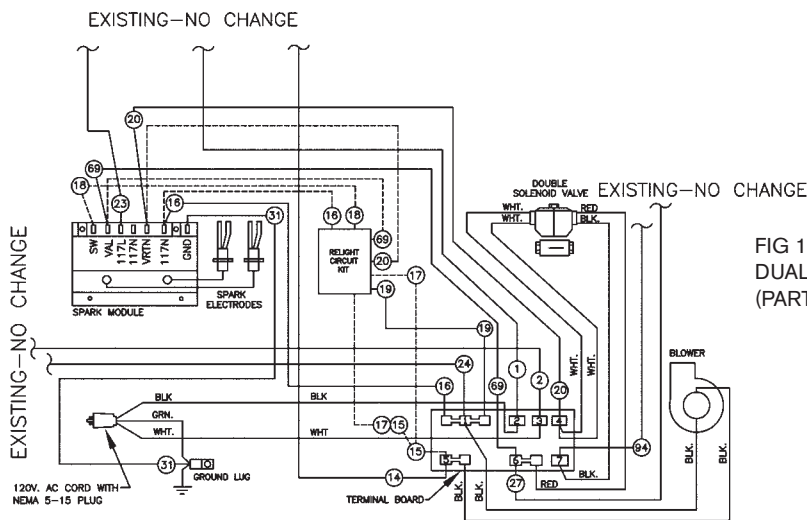

FIG 1. WIRING DIAGRAM FOR IFMs WITH DUAL-ELECTRODE SPARK IGNITION MODULE (PART # 019724) AND RELIGHT CIRCUIT KIT

2. Remove and discard the following wires: wire # 15, 17, 18, 19, 20, 69, 81, 82, 83, 84, 85, 86, 87 and 88. These wires are shown by dotted lines in Fig. 2 below. Also disconnect wire #26 (shown by a solid line in Fig. 2) from the relight circuit. Unscrew and discard all the relight circuit components.

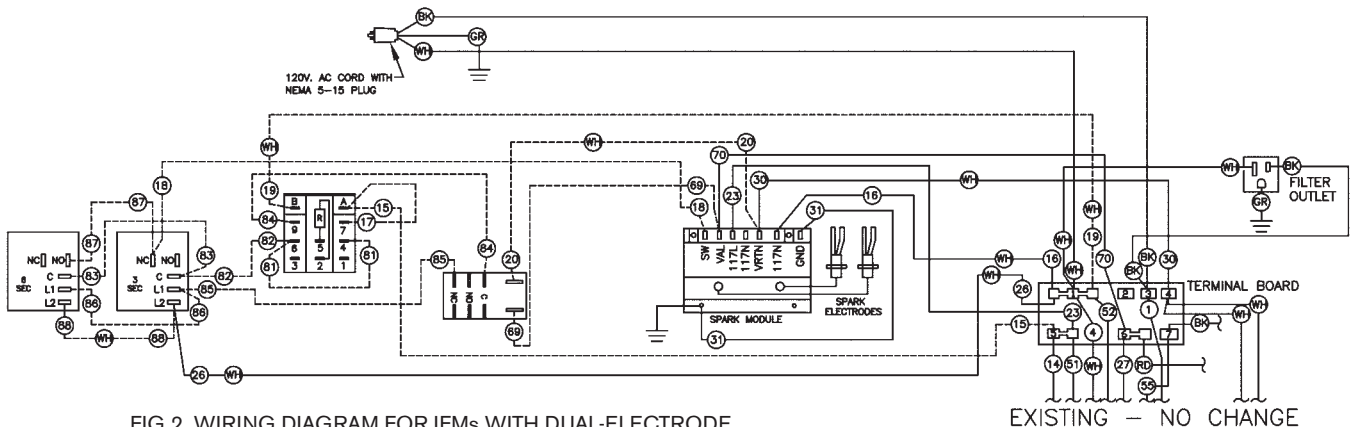

FIG 2. WIRING DIAGRAM FOR IFMs WITH DUAL-ELECTRODE SPARK IGNITION MODULE (PART # 019724) AND RELIGHT CIRCUIT



SERVICE INSTRUCTIONS

1-800-KEATING • keatingofchicago.com

INSTALLATION INSTRUCTIONS FOR SPARK IGNITION MODULE #037981

For IFMs With Spark Ignition Module Mounted on the Control Panel Back

Continued

3. Disconnect wire #16, 23, 30, 31 and 70 from the obsolete spark module.
4. Locate the two spark ignition electrode leads connected between the dual-spark ignition module and the two burner electrode assemblies that are mounted behind the IFM's control panel back.
5. For gaining access to the two burner electrode assemblies, unscrew and remove the control panel followed by the control panel back. Unplug both ends of each of the spark ignition electrode leads, one end from the obsolete spark module and the other end from the corresponding burner electrode assembly. Discard the two unplugged spark ignition electrode leads.
6. The dual-electrode obsolete spark ignition module should be totally disconnected from the IFM circuit. Unscrew and discard the module.
7. Drill holes and mount the two new modules (Part # 037978) keeping in mind the length of the new spark electrode leads (length: 24", Part #037551) and the space occupied by the two modules. Use pan head screws #8-32 x 3/4", #8-32 hex nuts and internal tooth lock washers #8.

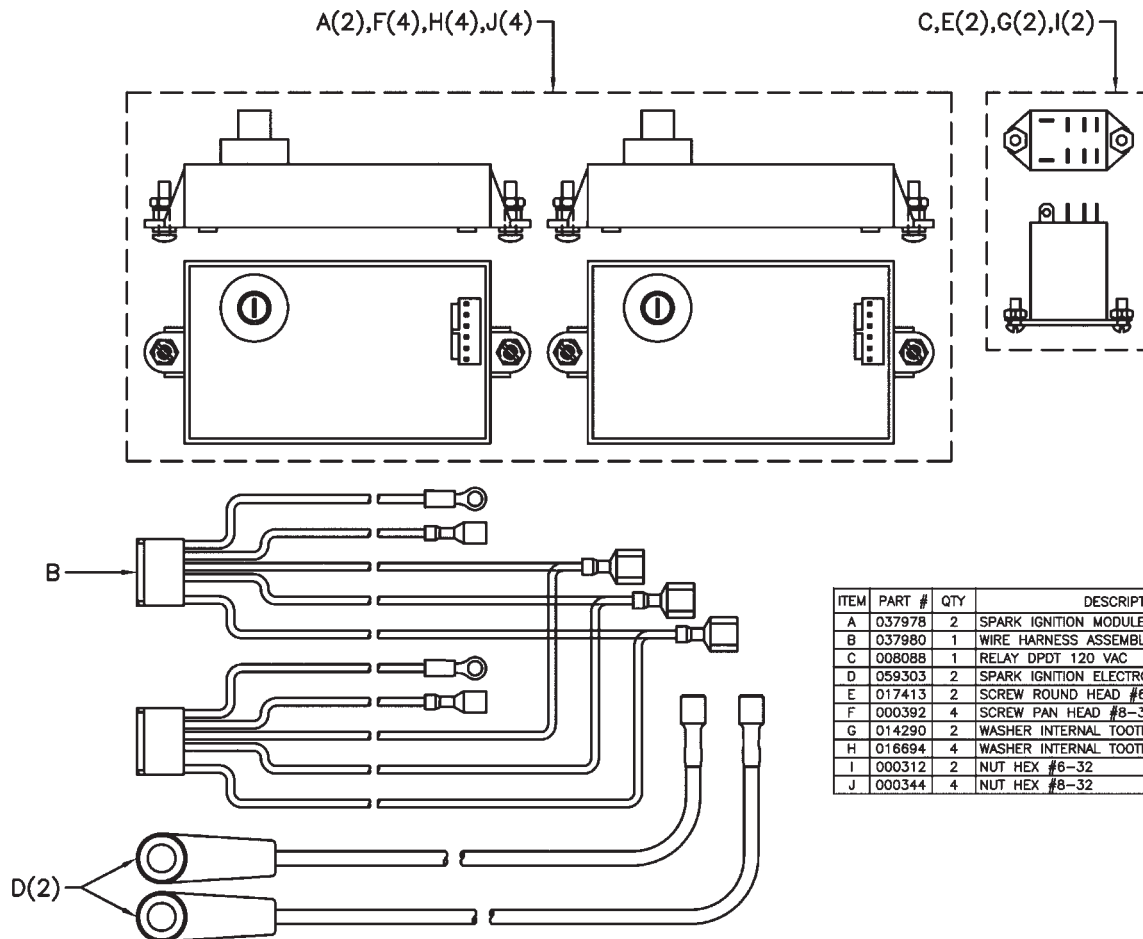

ITEM	PART #	QTY	DESCRIPTION
A	037978	2	SPARK IGNITION MODULE
B	037980	1	WIRE HARNESS ASSEMBLY
C	008088	1	RELAY DPDT 120 VAC
D	059303	2	SPARK IGNITION ELECTRODE LEAD 24"
E	017413	2	SCREW ROUND HEAD #6-32 x 3/8"
F	000392	4	SCREW PAN HEAD #8-32 x 3/4"
G	014290	2	WASHER INTERNAL TOOTH LOCK #6
H	016694	4	WASHER INTERNAL TOOTH LOCK #8
I	000312	2	NUT HEX #6-32
J	000344	4	NUT HEX #8-32



SERVICE INSTRUCTIONS

1-800-KEATING • keatingofchicago.com

INSTALLATION INSTRUCTIONS FOR SPARK IGNITION MODULE #037981

For IFMs With Spark Ignition Module Mounted on the Control Back Panel

Continued

8. Drill holes and mount the 120V AC DPDT relay with round head screws #6-32 x 3/8", #6-32 hex nuts and internal tooth lock washers #6. The location should be in accordance with the two new modules and the length of the wires on the wire harness.
9. Make connections between the two modules by installing the supplied wire harness. Refer to Fig. 3 below for detailed wiring. Dashed lines in Fig. 3 show the removed and discarded wires. Dashed lines in Fig. 3 show the added/rewired connections. Solid lines show unaltered wiring in both Fig. 1 and 2.

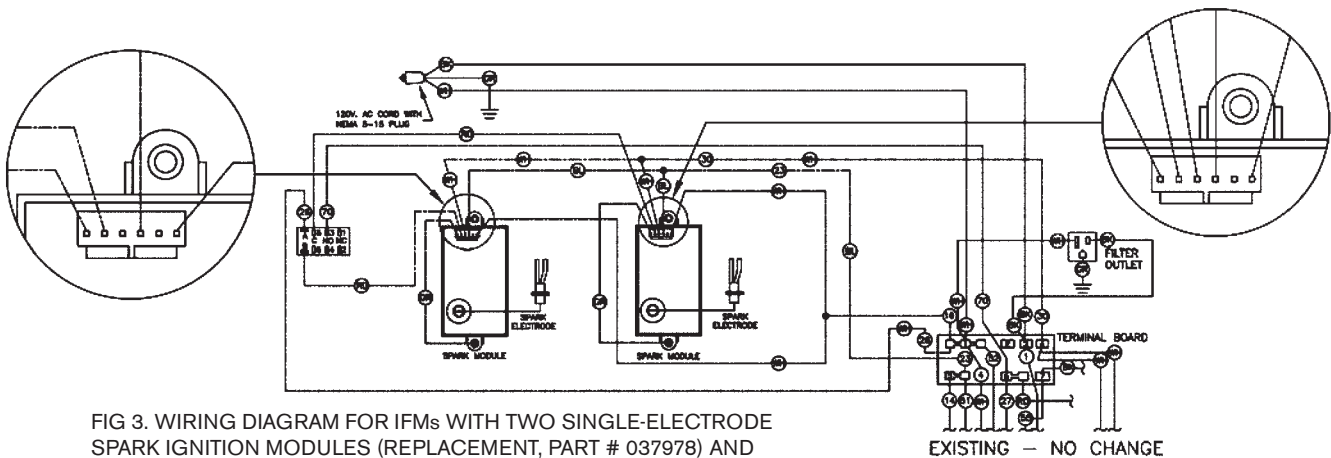

10. Connect the 1/4" quick disconnect end of the new spark electrode lead (Part # 037551) to the male tab of the single-electrode spark ignition module. Take the other end of the lead to the burner electrode assembly behind the IFM's control panel back. Repeat the same procedure for the other spark electrode lead. Do not alter the spark electrode gap when removing or connecting cables. Failed rectification or delayed ignition could occur. Secure the connections.
11. Re-attach the control panel back followed by the control panel.