



# SERVICE INSTRUCTIONS

1-800-KEATING • keatingofchicago.com

## SAFE & EASY FILTER REPLACEMENT OF MOTOR PUMP

Safe and Easy Filter Systems, size 14 inch through 34x24 inch, Field Kit instructions for removal of old motor pump and replacement with P/N 038176 motor pump with reset button.

Before attempting to remove the motor pump assembly, oil must be removed from the S&E filter unit. Follow directions in Safe & Easy® Filter Owners Manual, discarding the oil. Release the S&E filter unit and roll the S&E filter unit from the fryer.

Remove the filter tub from cart.

**NOTE:** The 34" x 24" filter unit tub is fixed to the cart and cannot be removed.

### ITEMS REQUIRED:

- SAFE & EASY OWNERS MANUAL
- TEFLON TAPE PIPE SEALANT
- POWER DRILL AND DRILL BIT SET
- HAND TOOLS TYPICALLY REQUIRED FOR REPAIR WORK ON FRYER AND FILTER SYSTEMS.

### FILTER DISASSEMBLY:

Remove the handles labeled "Pull to Release Tub", "Pull to Release Filter", and "Pull to Release Hose". Each handle is held in place by two 1/4-20 acorn nuts. Remove the black knob on the pump flow control handle (Figure 1, Figure 3, Figure 5).

Remove eight #10 sheet metal screws holding motor mount cover and remove the cover (Figure 3).

Disconnect the electrical wires at the the motor-pump and remove the motor reset button from the cover (Figure 3, Figure 7).

Remove the stainless steel corrugated flex line at both top and bottom connections. (Figure 4).

**NOTE:** The 34" x 24" filter tub is integral to the filter cart and does not contain a bracket coupler and quick connect coupler. Break the fluid line connection at the 1/2" compression fitting (Figure 1).

### KIT INCLUDES:

PART #	QTY	DESCRIPTION
059896	1	MOTOR PUMP WITH RESET BUTTON
059824	1	MOTOR PUMP SWITCH BOX
000374	2	6-32 x 5/8" ROUND-HEAD SCREW
016120	2	6-32 x 7/8" PAN-HEAD SCREW
014290	4	#6 LOCK WASHER
000312	4	NUT #6 HEX
037672	A/R	LOCTITE 262

Disconnect the assembly bracket coupler and the quick connect 3/8" coupler fittings (14" through 24" filter unit only). (Figure 1)

Remove four acorn nuts holding the reinforcement bracket, the front casters, and the motor mount weldment & motor sub assembly. Lift motor mount weldment and motor/pump sub assembly from the filter cart (Figure 1, Figure 2).

Remove four 5/16" hex screws holding the assembly bracket coupler (14" through 24" filter unit only). (Figure 1)

Remove four 5/16" hex screws holding the motor pump to the motor mount weldment (Figure 1).

Remove the motor pump assembly.



# SERVICE INSTRUCTIONS

1-800-KEATING • keatingofchicago.com

## SAFE & EASY FILTER REPLACEMENT OF MOTOR PUMP

*Continued*

### **MOTOR-PUMP MODIFICATIONS (Figure 6):**

**NOTE:** Use teflon tape on all male pipe connections. Remove two 1/2" comp x 1/2" MPT x 90° fittings from the old motor pump and reinstall them on the new motor pump such that they are in same orientation as before disassembly.

### **COVER MODIFICATION (Figure 3, Figure 7):**

Remove the rocker on/off switch and retain for reuse.

Use a #30 drill to remove the pop rivets holding the motor mount power switch bracket to the motor mount cover.

Install new motor mount power switch box into motor mount cover using 2 #6-32 x 1/2" torx pin head screws.

### **FILTER ASSEMBLY:**

Position the motor pump in the motor mount weldment and install four 5/16" hex screws, washers, and nuts (Figure 1).

Mount the assembly bracket coupler to the motor mount weldment with four 5/16" hex screws, washers, and nuts (14" through 24" filter unit only (Figure 1).

**NOTE:** The 34" x 24" filter tub is integral to the filter cart and does not contain a bracket coupler and quick connect coupler. Connect the fluid line connection at the 1/2" compression fitting (Figure 1).

Re-connect the assembly bracket coupler and the quick connect 3/8" coupler fittings. Use teflon tape on all male connections (14" through 24" filter unit only). (Figure 1)

Position the motor mount weldment & motor pump assembly in the filter cart frame (Figure 1, Figure 4).

Install the reinforcement bracket, the front casters, and the motor mount weldment & motor sub assembly using two screws and four acorn nuts with loctite (Figure 1, Figure 2).

Remove the control valve and quick connect assembly from the old motor pump at the 3/8" close nipple and reinstall them on the new motor pump such that they are in same orientation as before disassembly.

Note power switch box orientation in drawings front view with the reset switch hole on the bottom of box.

Reinstall the rocker on/off switch.

Do not install the motor reset button at this time.

Install the stainless steel corrugated flex line, both top and bottom connections. Use teflon tape on all connections (Figure 4).

Position the motor mount cover so the reset button can be installed. Fasten the reset button with two #6-32 x 7/8" pan-head screws (Figure 3).

Connect electrical wiring per wire diagram (Figure 7).

Install the motor mount cover using the eight #10 sheet metal screws (Figure 3).

Install handles "Pull to Release Tub", "Pull to Release Filter", and "Pull to Release Hose". Handles are held in place by two 1/4-20 acorn nuts and loctite (Figure 3, Figure 5).

Install the black knob on the pump flow control handle with loctite (Figure 1).

To test the filter unit, add oil and operate the filter through the pumping cycle per instructions in the owners manual.



# SERVICE INSTRUCTIONS

1-800-KEATING • keatingofchicago.com

## SAFE & EASY FILTER REPLACEMENT OF MOTOR PUMP DIAGRAMS

Figure 1

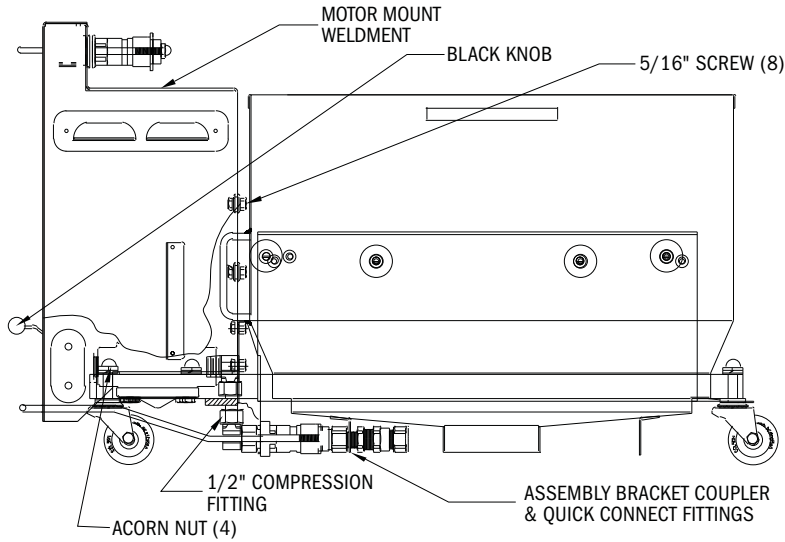

Figure 2

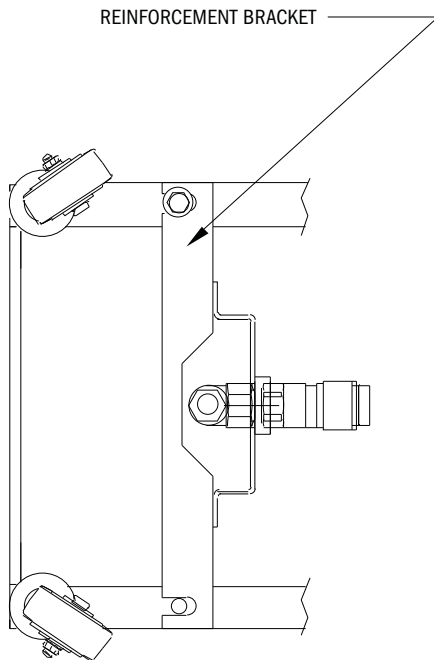
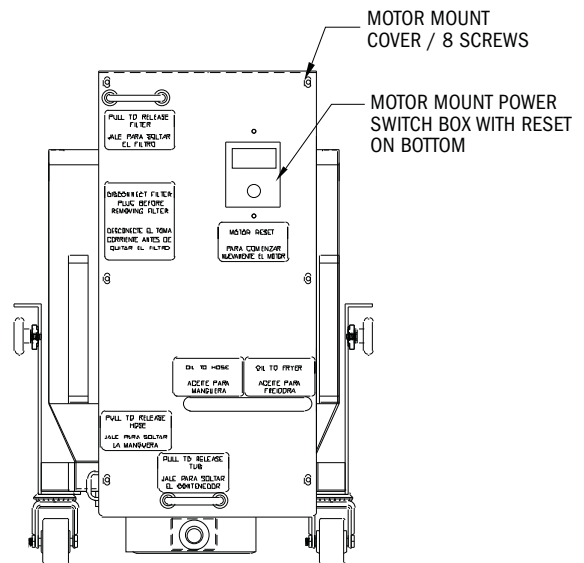

Figure 3





# SERVICE INSTRUCTIONS

1-800-KEATING • keatingofchicago.com

## SAFE & EASY FILTER REPLACEMENT OF MOTOR PUMP DIAGRAMS

Figure 4

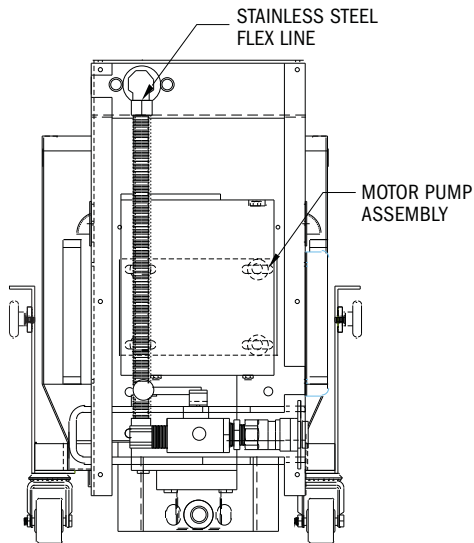

Figure 5

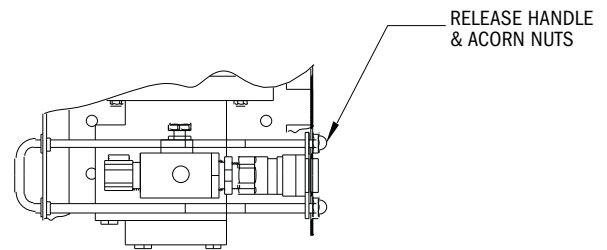

Figure 6

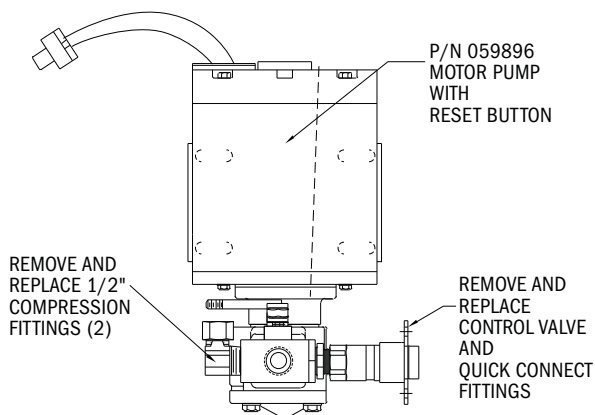

Figure 7

