



SERVICE INSTRUCTIONS

1-800-KEATING • keatingofchicago.com

INSTALLATION FOR RICHLITE CUTTING BOARD AND PLATE SHELF WITH BRACKETS ON KEATING GRIDDLES

REQUIRED TOOLS:

- Drill Gun
- #24 Drill Bit
- Phillips Screw Driver
- 10-24 Tap

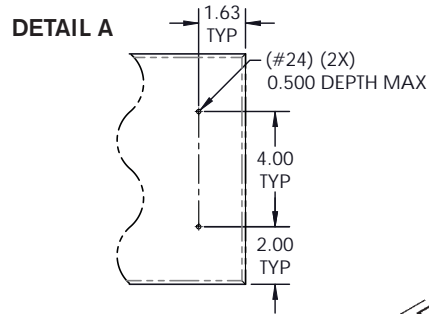

DETAIL B

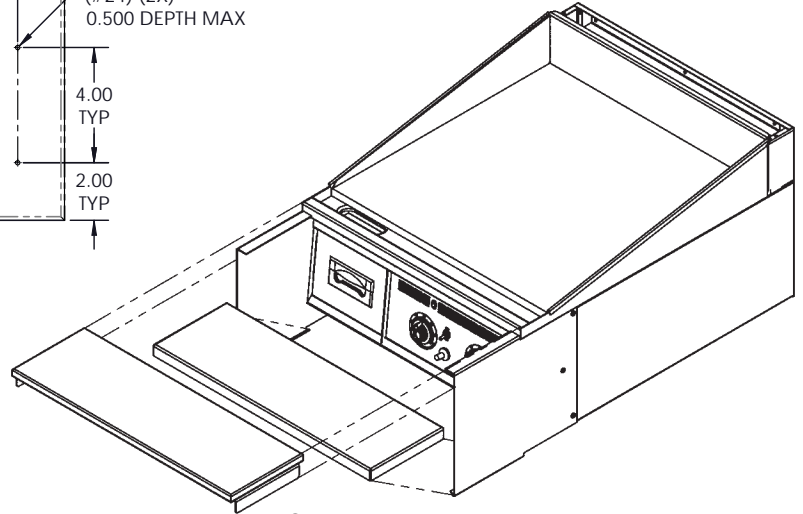
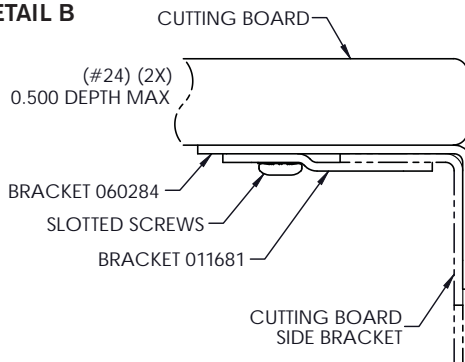

NOTE: When fully assembled, the cutting board should sit approximately 0.13 higher than front perimeter.

DETAIL C

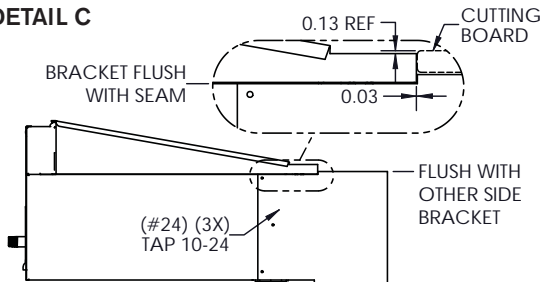

INCLUDED IN YOUR PACKAGE:

- A PRE-ASSEMBLED MOUNTING BRACKET FOR SECURING CUTTING BOARD TO SIDE BRACKET (2x)
- B END SUPPORT BRACKET (2x)
- C RICHLITE CUTTING BOARD (1x)
- D #10 SCREWS FOR ATTACHING BRACKET TO CABINET (6x)
- E CUTTING BOARD CENTER SUPPORT FOR 48" AND LARGER GRIDDLES (1x)
- F STAINLESS STEEL PLATE SHELF (1x)

1. Measure and mark mounting holes on the cutting board to the dimensions shown in Detail A.
2. Drill out marked holes in cutting board using a #24 drill bit to a maximum depth of 0.500.
3. Place brackets on top of each other, positioned as shown in Detail B, and fasten them to the cutting board using #10 x 1/2" slotted screws, supplied (NOTE: Do not tighten screws completely).
4. Hold the side mounting bracket in place (using orientation from Detail C). Mark the mounting holes on the cabinet sides. NOTE: Bracket tops must be as flat and parallel as possible for proper mounting of cutting board and plate shelf.
5. Drill out marked holes in cabinet sides using a #24 drill bit and 10-24 tap.
6. Attach side brackets to cabinet sides using #10 x 1/2" phillips screws, supplied.
7. Slide cutting board onto side brackets using orientation from Detail B, and tighten all screws.
8. Slide plate shelf between side brackets and hang on lower hooks.