



# SERVICE INSTRUCTIONS

1-800-KEATING • keatingofchicago.com

## FLEXIBLE TUBING TO HARD PIPING INSTALLATION INSTRUCTIONS FOR MOTOR/PUMP PART# 052982

USE THESE INSTRUCTIONS FOR THE FOLLOWING KIT PART NUMBERS:

057113	SE14
057114	SE18
057115	SE20
057116	SE24

### Operation #1 - Dis-Assembly

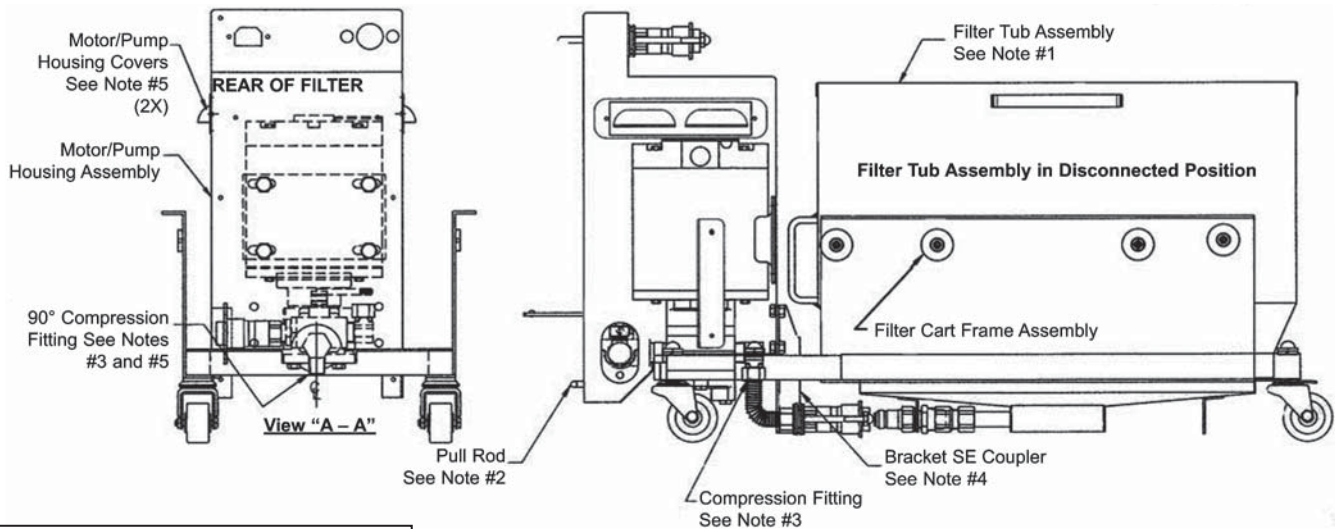

**CAUTION:**  
Make Sure Safety Glasses are Worn

### NOTES:

1. Drain and clean all oil from filter tub assembly. Remove filter tub assembly from filter cart frame assembly. This assembly will be turned over (upside down) for replacement of parts and adjustment to mating part on motor mount housing assembly.
2. Remove pull rod and set aside, this part will be used later.
3. Loosen compression fitting at pump output. Do not remove 90° fitting from pump.
4. Remove (4) bolts holding bracket SE coupler. This assembly will be replaced with new parts in kit. The bracket and flex tubing with quick connect are to be discarded.
5. Inspect 90° compression fitting on the pump as shown in view A-A. If the fitting is not on center line of the radius on the pump mount housing assembly as shown, use a #23 or #24 drill to remove pump housing covers (2) shown in view A-A to gain easier access to the top bolts holding the motor/pump. Loosen (4) bolts on motor/pump to center 90° fitting as best as possible. These covers will be re-assembled with screws in the kit. After adjustments are made to the motor/pump to center 90° compression fitting as shown in view A-A, tighten the (4) bolts for the motor/pump.



# SERVICE INSTRUCTIONS

1-800-KEATING • keatingofchicago.com

## FLEXIBLE TUBING TO HARD PIPING INSTALLATION INSTRUCTIONS FOR MOTOR/PUMP PART# 052982

Continued

Operation #2 - Re-Assembly

**Your Kit Includes (items with \* may not be included):**

Item	Part #	Qty	Description
A	-	-	-
*B	056990	1	PIPE NIPPLE 3/8" NPT X 1-1/2" SS-304
C	056915	1	BRACKET ASS'Y VIKING PUMP
D	020101	8	NUT 5/16" HEX HEAD SERRATED FLANGE
E	017142	4	SCREW 5/16-18 X 3/4" HEX HEAD
F	015227	2	NUT 1/4" ACORN S/S
G	004611	4	SCREW #10 X 3/8" SHEET METAL PAN HD.
*I	037672	A/R	SEALANT LOCKTITE 262 (.017 oz.)
J	056765	8	WASHER FLAT 7/16" ID X 1.00 OD X .078 THK
K	017481	4	SCREW 5/16-18 X 1-3/4" HEX HD
L	X	1	REINFORCEMENT BRACKET
M	015158	2	ACORN NUT 5/16-18 SS
N	053733	2	WASHER 11/32 ID X 3/4 OD SS
O	000290	2	WASHER, LOCK 5/16" SPLIT

**NOTES:**

- Remove filter tub from motor/pump housing assembly and set aside. On 18, 20 and 24 models only, remove pipe nipple 3/8" NPT x 1" and discard. Replace with pipe nipple 3/8" NPT x 1-1/2" (Item B). See View A for proper dimensions from back of sump to front of quick connect. On 14" filter tub, see View A for proper dimensions from back of sump to front of quick disconnect. Place the filter tub into the filter cart assembly. Release the filter tub away from the pump housing as shown in View B. Turn the entire assembly upside down as shown in View B. This step is critical to insure proper alignment between the motor housing quick connect and the filter tub quick connect. Use table or bench, making sure the motor/pump housing is off of the table/bench. **Caution:** if filter assembly is placed upside down on a table or bench, make sure unit is secure as not to slide off table/bench.
- Slide Item C into position to connect the compression fitting on the pump's 90° fitting. **Do not tighten compression fitting at this time.** Attach Item C to the pump housing with items D and E. **Do not tighten completely at this time.** Play must be present for proper alignment of pump housing connect and filter tub quick connect. Slide the filter tub assembly forward until the quick connects are engaged. Tighten Items D and E completely. Tighten compression on Item C. Remove (2) bolts and washers "K" and add reinforcement bracket "L." Use longer (2) bolts provided and discard old ones. For 20 and 24 models, add Items D and K to reinforcement bracket and tighten until snug on motor mount housing assembly (See Bottom View).

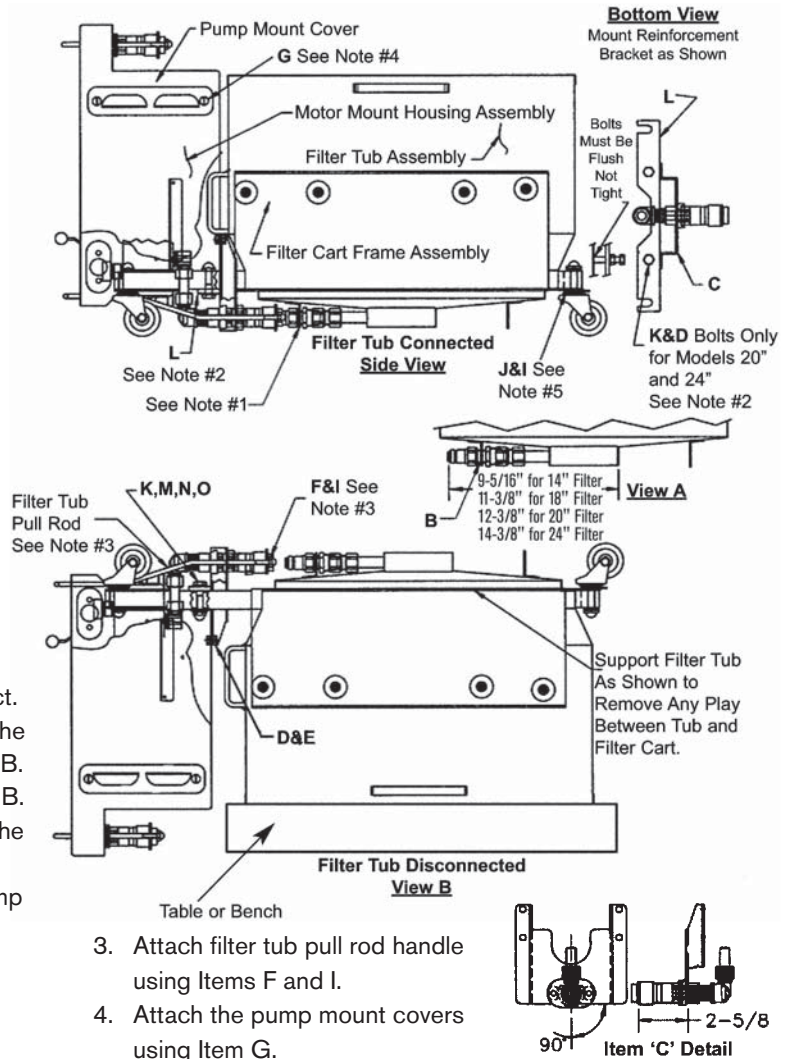

- Attach filter tub pull rod handle using Items F and I.
- Attach the pump mount covers using Item G.
- Inspect for spacers between casters and filter cart assembly. If none are present, remove casters and place Item J (2) on the casters threaded stem and reassemble using existing fasteners and Item I.
- Carefully turn filter assembly to the upright position. Release the filter tub pull rod and check for proper disconnect. Reconnect the filter tub to the motor mount housing using handles. If the assemblies do not connect properly, it will be necessary to verify notes above were followed correctly.
- Fill filter tub with oil per users manual, cycle oil to check for leaks at fittings, correct if needed.