

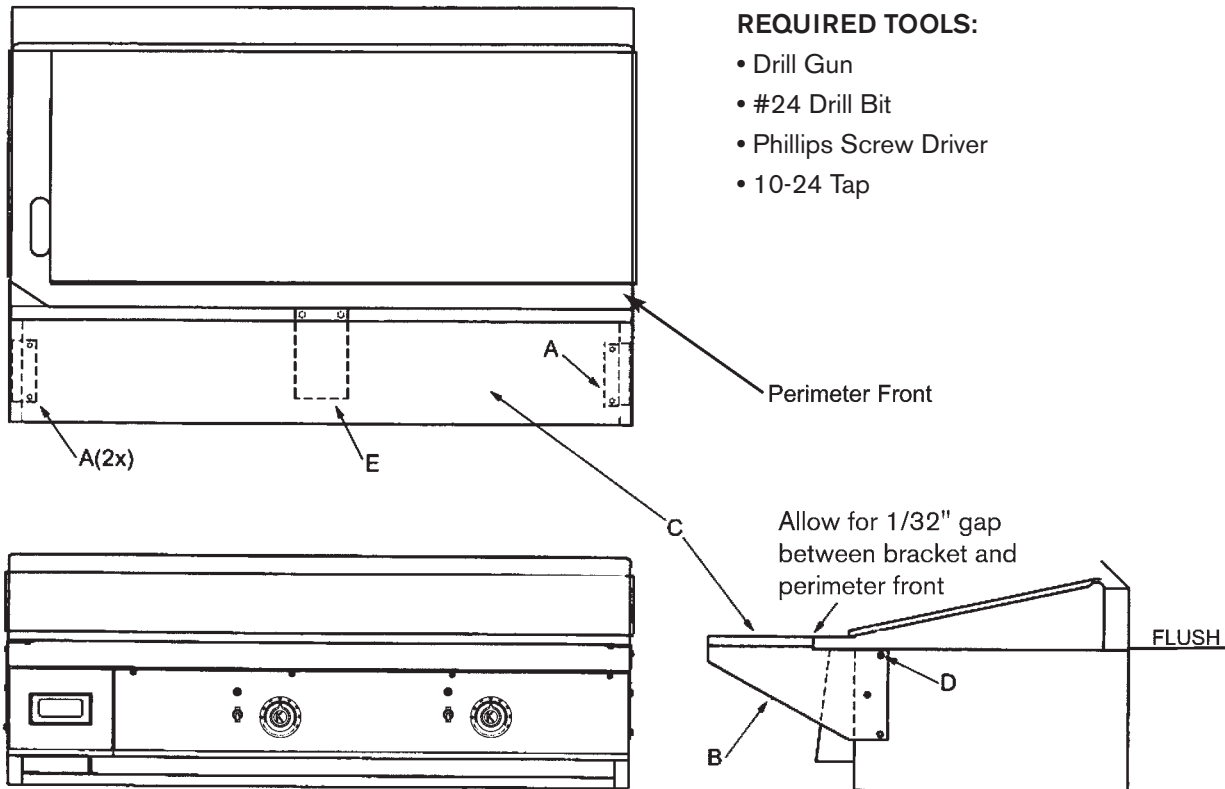

SERVICE INSTRUCTIONS

1-800-KEATING • keatingofchicago.com

INSTALLATION FOR RICHLITE CUTTING BOARD WITH BRACKETS ON KEATING GRIDDLES



INCLUDED IN YOUR PACKAGE:

- A PRE-ASSEMBLED MOUNTING BRACKET FOR SECURING CUTTING BOARD TO SIDE BRACKET (2x)
- B END SUPPORT BRACKET (2x)
- C RICHLITE CUTTING BOARD (1x)
- D #10 SCREWS FOR ATTACHING BRACKET TO CABINET (6x)
- E CUTTING BOARD CENTER SUPPORT FOR 48" AND LARGER GRIDDLES (1x)

1. Hold end support brackets in place and mark 3 holes on each side of cabinet. Top edge of bracket is to be flush with upper edge of cabinet side. 90° form on the bracket will extend out from the perimeter front.
2. Drill three holes on each cabinet side with the #24 drill bit and tap with 10-24 tap.
3. Attach end support brackets with #10-24 screws provided.
4. Loosen screws on cutting board bracket. Slide cutting board in place. Existing brackets on cutting board should mate with formed edges on end support brackets. Once in place, tighten screws.
5. Cutting boards 48" and longer also have a center support which attaches on the bottom side of the perimeter front (under the "CAUTION HOT" warning label) with existing 1/4-20 screws.