

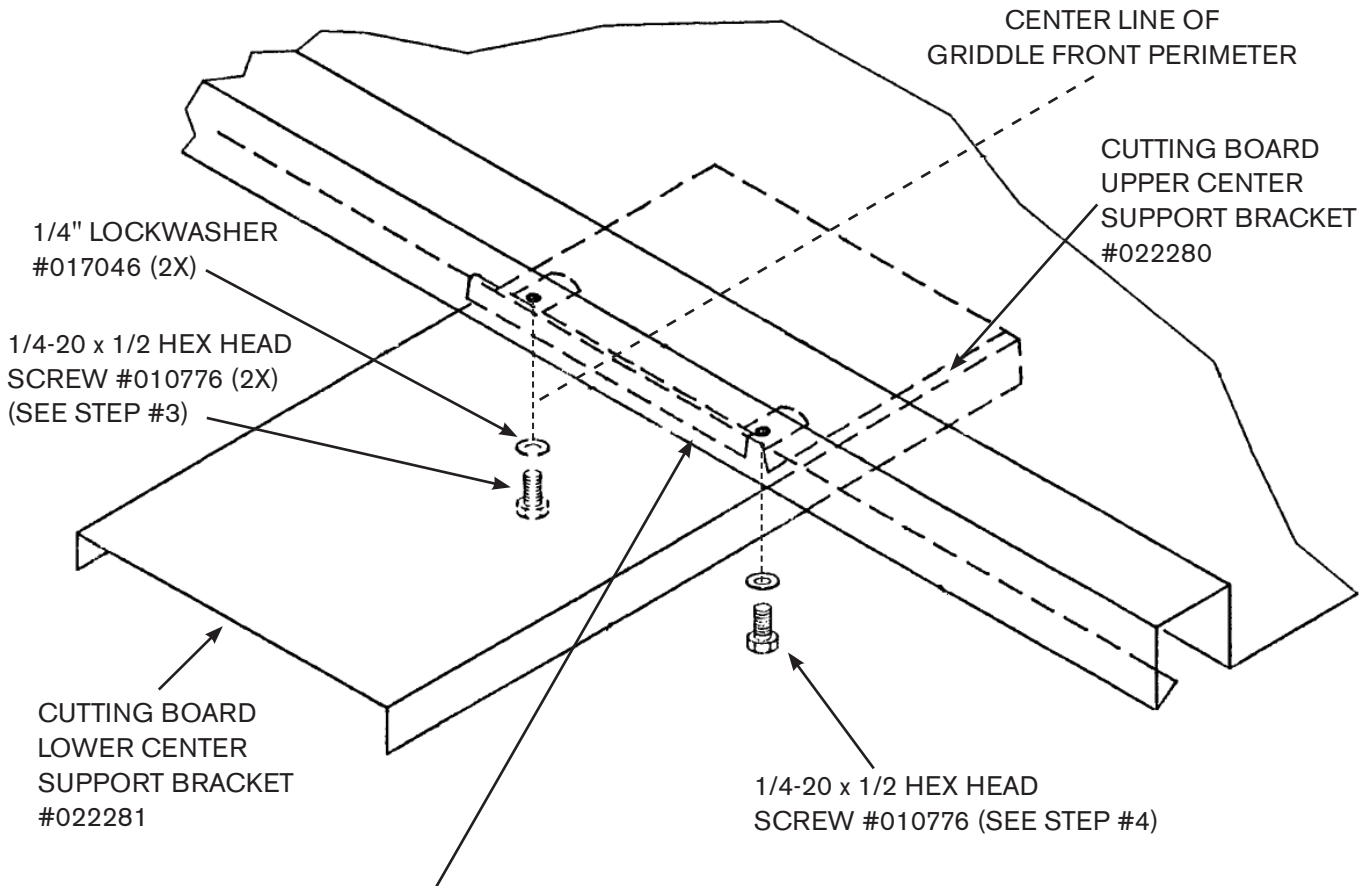

SERVICE INSTRUCTIONS

1-800-KEATING • keatingofchicago.com

INSTALLATION INSTRUCTIONS FOR CUTTING BOARD CENTER SUPPORT 48" GRIDDLE & UP WITH 135° BEND PRE-2000 SERIES



1. Hold center support upper bracket at angle and hook on to 135° bottom front edge of griddle perimeter.
2. Align center of support bracket with center of griddle perimeter.
3. Fasten lower bracket to upper bracket using (2) hex head screws and lockwashers.
4. Tighten assembly in place using hex head screw #010776. DO NOT OVERTIGHTEN.

NOTE: CENTER SUPPORT BRACKET MUST BE INSTALLED BEFORE CUTTING BOARD IS INSTALLED.