



SERVICE INSTRUCTIONS

1-800-KEATING • keatingofchicago.com



14IFM SE BUMPER GUARD INSTALLATION INSTRUCTIONS

Kit Includes:
Bumper Guard

Tools Needed:
7/16" socket & driver
7/16" open end wrench

| Item | Qty. | Description |
|------|------|--------------|
| A | 4 | Bolt 1/4-20 |
| B | 1 | Bumper Guard |
| C | 4 | Nut 1/4-20 |

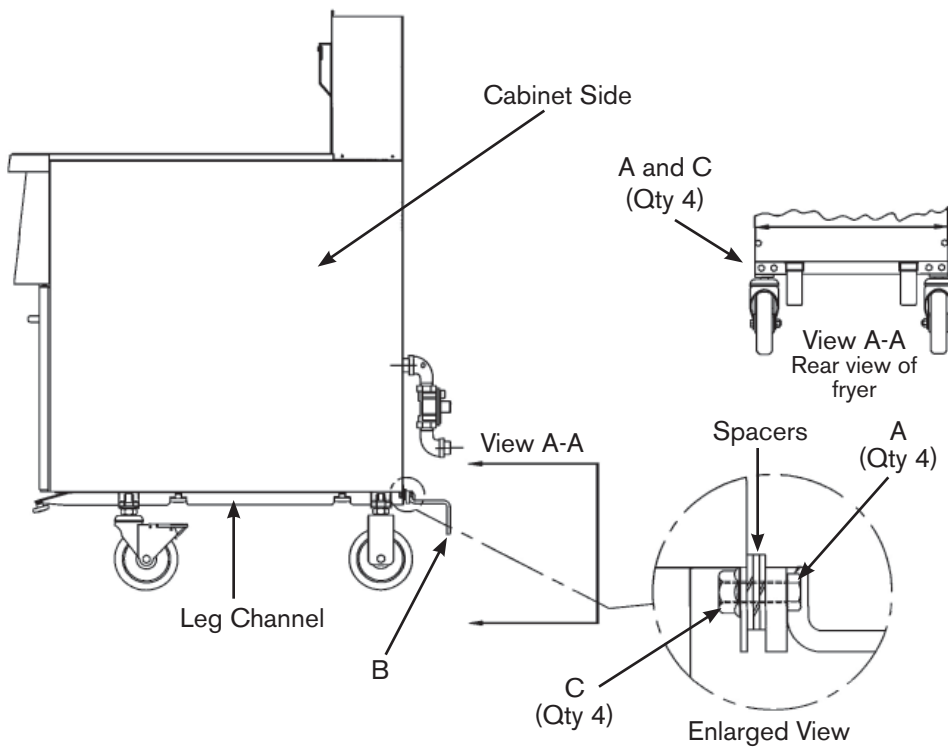

CAUTION: During assembly of Item B, sides of cabinet should be parallel. Clearance in mounting holes on cabinet sides, leg channels and bumper guard will allow adjustment when attaching hardware. Tighten bolts and nuts at the end of installation.

INSTRUCTIONS:

1. Remove bolts (A) and nuts (C) in rear of fryer using socket and wrench.
2. Remove bar currently in place (1/4"x1" bar stock).
3. Install bumper guard (B) in place of bar stock as shown above.
4. Reinstall bolts, nuts and spacers (A and C). **NOTE:** Keep loose until all four are in place.
5. Tighten bolts and nuts using socket and wrench.