



Model No. 20 IFM Gas Instant Recovery® Fryer

PROJECT \_\_\_\_\_

QUANTITY \_\_\_\_\_

ITEM NO. \_\_\_\_\_

**Standard Features:**

- ▶ 118,000 BTU input for cooking up to 140 lbs. of frozen french fries per hour
- ▶ New burner technology
- ▶ Instant-On™ System, with easy one button On/Off operation
- ▶ Instant Recovery® using less energy with more efficient, patented Wing Turbulators®
- ▶ Stainless Steel cabinet
- ▶ Polished Stainless Steel fryer vessel
- ▶ Extra large Cold Zone - 27% of fryer vessel
- ▶ Saves on oil costs/cooks at lower temperatures

**Options:**

- |   |  |
|---|--|
| <input type="checkbox"/> Computer                             | <input type="checkbox"/> Casters   |
| <input type="checkbox"/> Battery                              | <input type="checkbox"/> Thermostat Seal                                       |
| <input type="checkbox"/> Common Manifold                      | <input type="checkbox"/> Central Filter (CF20SE or above), Safe & Easy® Filter |
| <input type="checkbox"/> Basket-Lift                          | <input type="checkbox"/> Security Package                                      |
| <input type="checkbox"/> 2" Drain Valve (not available on SE) | <input type="checkbox"/> Cover   |



Casters Optional

The 20 Incredible Frying Machine® high efficiency, high production fryer lets you cook 140 lbs. of frozen fries or 200 lbs. of chicken per hour with an input of only 118,000 BTU. The Instant-On™ system anticipates large loads to handle peak cooking requirements. Indicating lights tell the status of the fryer and two digital timers with repeat memories ensures precise cooking times.

**Keating saves oil costs in three ways:**

- BETTER FRY POT DESIGN
- LARGER COLD ZONE
- INSTANT RECOVERY®

1. You shouldn't have to wait on the fryer. A properly designed fry pot ensures that the fryer has recovered its temperature before the end of the cooking cycle. Keating "INSTANT RECOVERY"® means continuous performance.
2. The Keating frying vessel is 27% Cold Zone, the food particles collected in the cold zone are unheated and therefore do not carbonize and contribute to premature shortening breakdown.
3. Keating's "INSTANT RECOVERY"® feature means frying at lower temperatures (325° – 335°F) extending oil life while enhancing product quality.

- **Oil Capacity - 100 lbs.**

**Easy to clean**

Keating uses only 304 stainless steel in its frying vessel design and polishes each vessel. The smoother the surface, the less carbon build-up occurs, making cleaning easier. A full 1-1/4" front drain allows easy draining of oil.

Safety controls ensure safe and accurate cooking. The patented and precise thermostat controls cooking temperatures to ± 3°F.

Hi-Limit control protects against the oil and fryer overheating.

Each fryer goes through a rigorous 100% test before shipping with every component carefully checked. The actual temperature test chart is included with each fryer.

**Special Order Options**

Keating gives you the widest range of options to ensure your fryer is exactly suited to your needs.



As continuous product improvement occurs, specifications may be changed without notice.

DATE \_\_\_\_\_

APPROVAL \_\_\_\_\_

SIGNATURE \_\_\_\_\_

[www.keatingofchicago.com](http://www.keatingofchicago.com)

20 IFM Gas Instant Recovery® Fryer

"Serving Those Who Serve The Very Best"®

**KEATING**  
OF CHICAGO, INC.

Model No. 20 IFM Instant Recovery® Fryer

A minimum of 24" at the front of the unit should be allowed for servicing and operation; a minimum of 6" on each side and at the rear of each unit for combustible materials.

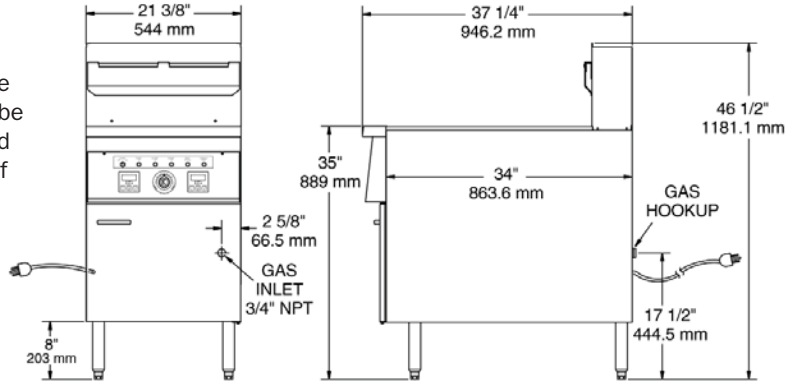

**SPECIFICATIONS**

**Fryer Vessel** - 18 gauge stainless steel a shortening capacity of 100 pounds. Equipped with four 18 gauge stainless steel, 3" wide x 5" high horizontal heat transfer tubes, spaced above the bottom of the vessel so that the bottom is unheated and the food particles collecting in the bottom zone are unheated and therefore do not carbonize. The vessel is polished to inhibit carbon buildup and facilitate easy clean-up. The bottom of the vessel slopes toward the front, and is equipped with a 1-1/4" Teflon core 1/4 turn, drain valve, so the shortening can be drained into a receiving vessel placed in front of the fryer.

**Splashdeck** - 16 gauge, 304 stainless steel. It slopes toward the shortening containing vessel.

**Splashback** - 18 gauge, 304 stainless steel. It completely covers the side of the flue.

**Cabinet** - 18 gauge stainless steel. Rigid in construction, with four 8" adjustable legs. The cabinet door is made of 22 gauge 304 stainless steel. The door covers the front of the cabinet from the bottom of the fryer to the fryer panel, and the full width of the cabinet. Above the panel is a canopy. No additional space is required for the door to open a full 90 degrees. A stainless steel flue deflector is provided for installing onto the flue back.

**Electronic Ignition** - Automatically lights burners. There is no standing pilot to struggle to light.

**Burners** - Two inconel mesh tubular style burners encased in ceramic cloth with rated output of 59,000 BTU/hr natural gas per burner.

**Heat Transfer Tubes** - Four heat transfer tubes, made of stainless steel polished to a #7 mirror finish. The middle tubes have a patented recycle baffle inside to increase efficiency.

**Timers** - Two electronic timers (programmable for three products each), Instant-On™ Start System.

**Thermostat** - Close range, hydraulic type, is accurate to ±3°F from 300° to 350°F with stainless steel bulb. Application of this thermostat is patented by Keating.

**Hi-Limit Control** - Manually resettable type with stainless steel bulb.

**100% Safety Shut-Off** - Electronic type with combination control gas valve.

**Indicating Lights & Switches** - On-Off switch, power on light (white), blower on light (blue), burner on light (amber), ready to fry light (green), over max temp (red).

**Standard Accessories** - Includes Instant-On™, one pair 4 mesh baskets, grid screen over heat transfer tubes, drain clean out rod, and sample of Keating Klenzer.

**Electrical Requirements** - Supply Voltage 120V 60Hz, Control Voltage 24V 60 Hz, 120 VAC 9' (1.5m) grounded cord set provided.

**Gas Requirements** - Install a 3/4" male NPT connection and 3" water column pressure (natural gas) and 10" (LP) at the fryer burner manifold. Supply pressure to fryers must be 7" (natural gas) and 11" (LP) water column.

**Special Order Options** may include computer, battery, common manifold, casters, cover, thermostat seal, central filter (CF20SE or above), Safe & Easy® Filter, basket-lift, 2" drain valve (not available on SE) and security package.

**INSTALLER** - Check plumbing and gas codes for proper gas supply line sizing to sustain burner pressure when all gas appliances are full on. Supply pressure must NOT be above 13.84" WC or gas valve damage may occur.

GAS REQUIREMENTS / DIMENSIONS\*

MODEL	BTU Input	Height	Depth	Width	Weight
20 IFM Natural Gas	118,000	46 1/2"	37 1/4"	21 3/8"	260 lbs.
20 IFM LP Gas	118,000	46 1/2"	37 1/4"	21 3/8"	260 lbs.

\* Dimensions for Model 20 IFM Safe & Easy: Height, 46 1/2", Depth 38 5/8" and Width 21 3/8". Weight is N/A.

As continuous product improvement occurs, specifications may be changed without notice.

[www.keatingofchicago.com](http://www.keatingofchicago.com)

20 IFM Gas Instant Recovery® Fryer