



TOP-SIDE™ COOKER SERIES 2005

MANUAL

■ IMPORTANT:

THIS MANUAL PROVIDES SPECIFIC OPERATING INSTRUCTIONS FOR YOUR MODEL. USE THE TOP-SIDE™ COOKER ONLY AS INSTRUCTED IN THIS MANUAL.

KEEP A COPY OF YOUR BILL OF SALE.

The date on the bill establishes the warranty period should service be required. If service is performed, it is in your interest to obtain and keep all receipts.

KEEP THIS MANUAL FOR TRAINING NEW PERSONNEL.

Record the Serial number and Model number of this Keating Top Side™ Cooker in the spaces provided. **Keep these numbers for future reference.**

SERIAL NUMBER

MODEL NUMBER

The Keating Top-Side™ Cooker is not intended for household use.

As continuous product improvement occurs, specifications may be changed without notice.

1-800-KEATING | keatingofchicago.com

NOTE:

PURCHASER SHOULD POST IN A PROMINENT LOCATION.

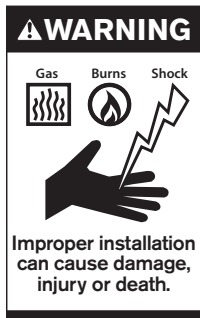

⚠ WARNING

Improper installation, adjustment, alteration, service or maintenance can cause property damage, injury or death. Read the installation, operating and maintenance instructions thoroughly before installing or servicing this equipment.



FOR YOUR SAFETY:

Do not store or use gasoline or other flammable vapors or liquids in the vicinity of this or any other appliance.



⚠ WARNING

Before obtaining access to terminals, all supply circuits must be disconnected.



■ TABLE OF CONTENTS

Important Safety Instructions i

INTRODUCTION 1

Standard Features 1

Safety Precautions 2

INSTALLATION 2

Damage During Shipment 2

FIRST STEPS 2

Electrical Connection 3

Wire Size 3

OPERATING 3

Conditioning the Miraclelean® Plate 3

Cooking 3

Cooking Height Adjustment 3

Digital Timer Programming 4

Shutdown 4

Cleaning Procedures 4

 Cooking Sheet 4

 Cooking Sheet Clips 4

 Cooking Head 4

MAINTENANCE 5

Warranty Repairs 5

Preventative Maintenance 5

Installing a Cooking Sheet 5

Handling a Cooking Sheet 6

Removal of Cooking Head 6

Setting the Offset on the Top-Side™ Thermostat 6

SERVICE DIAGNOSIS 6

Troubleshooting Chart 7

Troubleshooting the Thermostat 7

Injecting/Replacing Grease Fitting 8

ORDERING PARTS 8

Warning and Operating Plates 8

Manual Lift Top-Side™ Cooking Head (Exploded View) 9

Cooking Head Parts List 10

Auto-Lift Top-Side™ Cooking Head 11

Auto-Lift Top-Side™ Actuator Microswitch 12

Control Panel Assembly 13

Power Supply Box Auto-Lift Head 14 - 15

WIRING DIAGRAMS 16 - 19

■ INTRODUCTION

Instructions in this manual should be read thoroughly before attempting to operate this Keating Top-Side™ Cooker. All installation and service on Keating equipment must be performed by qualified, certified, licensed and/or authorized installation or service personnel.

Operating information for Keating equipment has been prepared for use by qualified and/or authorized personnel.

Keating equipment is made in the USA and has American sizes of hardware. All metric conversions are approximate.

GENERAL

Keating Top-Side™ Cookers are designed to give maximum production efficiency, delivering high quality food products. The following design features are incorporated into Keating Top-Side™ Cookers.

STANDARD FEATURES

- Miraclelean® cooking surface
- Stainless steel control panel
- Stainless steel head cover
- Solid State Thermostat
- Adjustable cooking height, from 1/8" to 1 1/2" (3mm to 38mm)
- Locking mechanism for Micro-Level

STANDARD ACCESSORIES

- Proprietary polymer cooking sheet (1)

NOTE:

Keating of Chicago, Inc. (manufacturer) reserves the right to change specifications at any time.

COOKING HEAD SPECIFICATIONS

Each Top-Side™ cooking head is designed to be connected to a 208, 220 or 240 volt single phase line.

HEIGHT	WIDTH	DEPTH	WATTS	AMPS	kW
3 5/8" (92mm)	10 1/2" (267mm)	20" (508mm)	4000 @220V	18 @220V	4.0 @220

STANDARD TOP-SIDE™ COOKERS

- Sizes: 1 to 6 heads.
- Mounting: Can be mounted to any standard Miraclelean® gas or electric 30" (762mm) deep griddle (24" deep plate / 610mm) up to 72" wide (up to 6 heads maximum). Front trough only griddles are preferred for multiple heads.
- Cooking Surface: 10 1/2" (267mm) wide x 20" (508mm) deep (per cooking head).
- Number of heads: One head can be used for every 12" (305mm) of plate width. Each Top-Side™ cooking head will be positioned over a griddle thermostat to ensure peak efficiency.
- ETL and ETL Sanitation Listed.

■ SAFETY PRECAUTIONS

⚠ WARNING

THIS SYMBOL WARNS YOU THAT SERIOUS BURNS OR OTHER INJURIES MAY RESULT IF SAFETY INSTRUCTIONS ARE NOT FOLLOWED.

- DO NOT SUBMERGE THE TOP-SIDE™ COOKING HEAD IN WATER.
- CLEANING CHEMICALS OR UTENSILS USED FOR CLEANING GRIDDLES WILL DAMAGE OR DESTROY THE POLYMER COOKING SHEET.
- NEVER USE A WATER JET TO CLEAN.

■ INSTALLATION INSTRUCTIONS

This Top-Side™ Cooker must be installed on a Keating griddle only. Failure to do so voids the warranty.

On new installations, your Top-Side™ Cooker has already been factory installed, tested, leveled and inspected. Top-Side™ Cookers cannot be mounted onto existing Miraclean® griddles in the field.

The Top-Side™ Cooker must be installed, inspected, calibrated and serviced by qualified, certified and/or licensed service personnel. Contact your dealer for assistance.

Proper installation will assure top performance. Alterations of any kind to your equipment will void the warranty. Before uncrating, check equipment carefully for damage.

INSTALLATION

Installation must conform with local codes or, in absence of local codes, with the current National Electrical Code ANSI/NFPA 70 or Canadian Electrical Code CAN22.2 as applicable.

IF EQUIPMENT ARRIVES DAMAGED

Keating does not assume responsibility for loss or damage incurred in transit.

IMPORTANT

This merchandise has been thoroughly inspected and carefully packed before leaving our plant. Responsibility for its safe delivery was assumed by the carrier at the time of shipment. Claims for loss or damage to the contents should, therefore, be made upon the carrier, as follows:

CONCEALED LOSS OR DAMAGE

Concealed loss or damage means loss or damage which does not become apparent until the merchandise has been unpacked. The contents may be damaged in transit due to rough handling even though

the carton may not show external damage. When the damage is discovered upon unpacking, make a written request for inspection by the carrier's agent within fifteen days of the delivery date. Then file a claim with the carrier since such damage is the carrier's responsibility. By following these instructions carefully, we guarantee our full support of your claims to protect you against loss from concealed damage.

VISIBLE LOSS OR DAMAGE

Any external evidence of loss or damage must be noted on the freight bill or express receipt, and signed by the carrier's agent. Failure to adequately describe such external evidence of loss or damage may result in the carrier refusing to honor a damage claim. The form required to file such a claim will be supplied by the carrier.

DO NOT RETURN DAMAGED MERCHANDISE TO KEATING. FILE YOUR CLAIM AS STATED.

■ FIRST STEPS

ELECTRICAL CONNECTION

Each Keating Top-Side™ Cooking head is equipped with a 9' (2.74m) neoprene covered, 12 gauge 4mm(2), three wire with ground electrical cord. Each cooking head is rated 4000W, 18 amps, single phase at 220 Volts and is designed to be connected to its own 208-240V single phase electrical supply. For proper connecting and grounding procedures see local codes, the National Electrical Code ANSI/NFPA 70 (latest edition) or Canadian Electrical Code CAN C22.2 (latest edition) as applicable.

⚠ WARNING

THIS APPLIANCE MUST BE EARTHED.

WIRE SIZE

Use the **WIRE SIZE TABLE** to help determine the proper wire size for electrical service hook-up. Use the largest amp value of the three conductors for 3-phase installations when using the table. The amperage values for a product can be found on its serial number tag. Consult the National Electrical Code Handbook for additional information or to help answer questions about wire size selection.

WIRE SIZE TABLE

Conductor Current (Amps up to)	Recommended Wire Size (AWG)
15	14*
20	12*
30	10*
40	8
55	6
70	4
95	2
125	0
145	2/0
165	2/0**
190	2/0**

*For runs greater than 75' up to 125', use the next wire size larger to keep the voltage drop to less than 3%. For runs greater than 125', consult the National Electrical Code Handbook to help determine the proper wire size.

**2/0 wire ambient temperature must be kept at less than 104°F (40°C).

■ OPERATING

⚠ CAUTION

Food will cook much faster with a Top-Side™ Cooker than with a griddle alone. Watch food while cooking or use timers to ensure food will not be overcooked.

⚠ WARNING

OPERATION OF THE TOP-SIDE™ COOKER SHOULD BE LIMITED TO PERSONNEL THOROUGHLY TRAINED IN OPERATING PROCEDURES.

CONDITIONING THE TOP-SIDE™ MIRACLEAN® SURFACE

The Miraclean® surface has been “seasoned” at the factory. The chrome surface when heated creates a thin layer of chrome oxide which acts as a releasing agent for food products. If you feel you need to recondition the surface, the following instructions should be followed:

1. Follow cleaning instructions on page 4.
2. Heat the Miraclean® to 400°F for one hour.
3. Lower thermostat to 350°F, allowing the Miraclean® to cool to about 350°F, as is evident when griddle cycles on or surface thermometer indicates correct temperature.

4. Lightly coat the Miraclean® surface with griddle oil.

NOTE: Despite the food releasing properties, the chrome surface is not a true “non-stick” surface. For best cooking results and product appearance, use griddle oil for products that require the surface to be conditioned.

COOKING

1. Turn ON/OFF switch to “ON” position.

NOTE: Because of the superior heating characteristics and heat retention properties found in the Miraclean® surface, operating temperatures should be set 10°F to 25°F below conventional griddles.

2. Press and hold the “Push to Set” button on the thermostat and adjust the knob to the desired temperature. The new temperature will be entered after 3 seconds. Red “ELEMENT ON” light will illuminate when the element is on.

NOTE: To increase temperature, adjust knob clockwise. To decrease, adjust knob counterclockwise.

Figure 3-1

Top-Side™ Cooker Control Panel

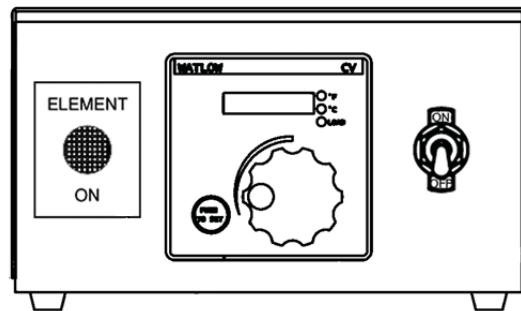

COOKING HEIGHT ADJUSTMENT

Keating's Top-Side™ Cooker has been designed to allow you infinite height adjustments from 1/8" to 1-1/2" (approximately 3mm to 38mm). An adjusting knob allows fast and precise height adjustment.

Clockwise movement of the knob will decrease the spacing; counter clockwise movement will increase the spacing. Each turn of the adjusting knob represents 1/8" (approximately 3mm) movement.

Experimentation will give you the best cooking height for each type of food product. The cooking head should contact the product firmly to ensure optimum heat distribution without flattening the product.

DIGITAL TIMER PROGRAMMING FOR AUTOLIFT HEADS

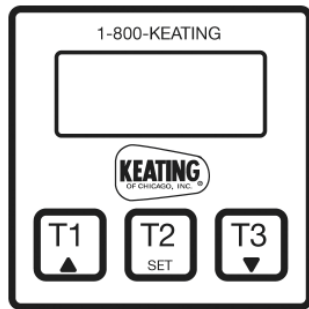

The electronic timers provide a clearly visible and accurate display and are very easy to use. Three different, independent cook times can be set using this timer - T1, T2 and T3. When cook time has reached "00:00", the cooking head will automatically raise.

PROGRAMMING

To program the timers, the unit must be in the idle mode. Press and hold the set button for approximately two seconds. The display will show "SEt". Press T1, T2 or T3 for the cook time to be programmed. The display will show the current setting for that cook time. Use the up or down button to increment or decrement the setting. When the setting is correct, press and hold the set button again for approximately two seconds. The display will show "StO" for approximately two seconds and the timer will return to normal operation. Repeat the process as necessary for the other timers.

OPERATING LOGIC

When the timer is powered up, the display will show the time setting for the channel that was operated last and the relay output contacts will be open. To start a cycle, press the desired cook time button (T1, T2 or T3). The display will begin to countdown from the preset time setting and the relay output contacts will close. During the countdown the colon will flash at a one-second rate. When the countdown has reached "00:00" the relay output contacts will open, the display will flash, and the audible alarm will sound. To cancel the audible alarm, press any button.

PAUSE FEATURE

To pause a cycle in progress, press any button. The relay output contacts will open, the display will flash, and the countdown will pause. To resume the countdown, press any button. The display will resume the normal countdown and the relay output contacts will close.

SHUTDOWN

Turn On/Off switch to "OFF" position.

CLEANING PROCEDURES

A. Keating Cooking Sheets

Clean cooking sheets with a damp soft cloth after each run of product (a Turkish towel works best).

⚠ WARNING

THE COOKING HEAD WILL BE HOT. USE PROPER CARE WHEN CLEANING THE COOKING SHEETS.

End of day cleaning:

Before the griddle is turned off for the day, the cooking sheets should be cleaned as described below. Wear heat resistant gloves for maximum safety during the entire cleaning procedure.

1. At the end of the day, wipe the cooking sheet in place with a damp soft cloth. Continue wiping until the surface of the cooking sheet is free of any residue.
2. Remove the cooking sheet from the cooking head. Clean the cooking head and the griddle surfaces.
3. Wash the cooking sheet in a sink with a mild detergent in warm water and dry thoroughly.
4. If needed, after the cleaning is complete, reverse the cooking sheet and reattach it to the cooking head.

B. Cooking Sheet Clips

To remove the stainless steel cooking sheet clips for cleaning, simply lift them off. They can be cleaned in a dishwasher.

C. Cooking Head

The Miraclean® surface is very durable and with proper care, following the procedures below, will last many years.

1. Scrape Miraclean® surface from front to back with the Keating griddle scraper with Cooking Sheet removed.
2. Clean and polish surface with Keating Klenzer on a damp soft cotton cloth. Wipe off excess Klenzer.

⚠ WARNING

NOTE: BECAUSE OF THE SUPERIOR MIRACLEAN® SURFACE, THE ONLY TOOLS YOU WILL EVER NEED TO CLEAN THE TOP-SIDE COOKING HEAD ARE A DAMP SOFT COTTON CLOTH AND A KEATING SCRAPER.

- NEVER SCRAPE COOKING SHEETS WITH THE SCRAPER.
- NEVER USE A GRIDDLE STONE, BRICK, GRIDDLE SCREEN OR HARSH CHEMICALS TO CLEAN THE COOKING HEAD MIRACLEAN® SURFACE.
- DAMAGE DONE TO THE MIRACLEAN® SURFACE BY GRIDDLE STONE, BRICK, SCREEN OR HARSH CHEMICALS WILL VOID THE WARRANTY.
- THE DAMAGE DONE TO THE MIRACLEAN® SURFACE IS IRREPARABLE.
- NEVER USE ICE TO COOL THE MIRACLEAN® SURFACE. USE OF ICE MAY WARP THE MIRACLEAN® PLATE.
- USE ONLY KEATING SUPPLIED CLEANING TOOLS AND KLENZER.
- USE ONLY A KEATING STEEL SPATULA.

NOTE: Keating Klenzer MSDS is available on our website.

⚠ CAUTION

DO NOT HACK, CHOP, HIT OR CUT ON THE MIRACLEAN® SURFACE.

You will dent the steel plate under the trivalent chrome. It is even possible to hack two nicks close together and actually tear the MiracleClean® surface as the chromium will not stretch. Below is a sketch showing the side view of a cooking head and how the surface can be damaged. Proper use of the utensils supplied with your MiracleClean® Griddle will prevent surface damage.

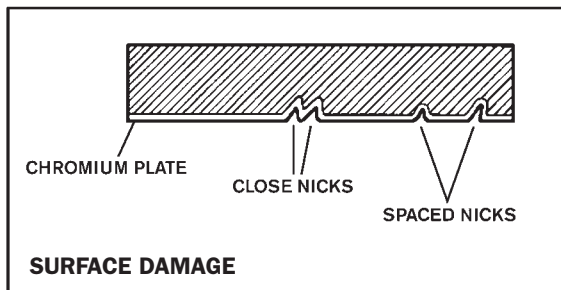

■ MAINTENANCE

WARRANTY REPAIRS

Keating's warranty begins with the date of installation. In the event that your Top-Side™ Cooker, under warranty, needs repairs other than routine maintenance or cleaning, you are required to contact Keating of Chicago (at 1-800-KEATING) before calling a local service company.

NOTE: The cooking sheets are not covered under warranty.

PREVENTIVE MAINTENANCE

Preventive maintenance should be done in daily, weekly, monthly and yearly intervals as necessary. Following preventive maintenance procedures will help keep your Top-Side™ Cooker working efficiently. Proper care and servicing will lead to years of quality performance.

PREVENTATIVE MAINTENANCE CHART

TIME FRAME	OPERATOR/OWNER
AT LEAST DAILY*	<ul style="list-style-type: none"> • Clean all Cooking Sheets. • Clean MiracleClean® griddle surface.
AT LEAST WEEKLY*	<ul style="list-style-type: none"> • Clean all surfaces of Top-Side™ Cooker. • Wipe shaft of actuator when fully extended with dry cloth. • Wipe motor/shaft housing with dry cloth.
AT LEAST MONTHLY*	<ul style="list-style-type: none"> • Verify thermostat settings. • Review cooking procedures. • Check Cooking Sheets. (Replace if necessary).
TIME FRAME	QUALIFIED SERVICE PERSONNEL
AT LEAST YEARLY*	<ul style="list-style-type: none"> • Have Top-Side™ Cooker completely checked, calibrated, tested, cleaned, etc. by qualified service personnel.

*High production facilities should be checked more often. Contact the factory or a local service company to perform maintenance and repairs.

⚠ CAUTION

Damage done to the MiracleClean® surface is irreparable and is not covered under Keating Warranty.

INSTALLING A COOKING SHEET

1. Raise Top-Side™ Cooking head completely.
2. Lay the 20" x 24" (508mm x 610mm) cooking sheet on the griddle plate with 20" (508mm) dimension front to back.
3. Lower the Top-Side™ Cooker head onto the cooking sheet, ensuring that the sheet is centered under the head, the front edge of the sheet is even with the front edge of the head, and the sides of the sheet are parallel to the side of the head.
4. Fold both edges of the cooking sheet over the head. While gently pulling the right side of the sheet to remove any slack, firmly push the cooking sheet mounting clip onto the right side mounting rib on top of the head.

5. Repeat process on the left side.
6. Reverse the process to remove the cooking sheet.

TIPS ON PROPER HANDLING AND USE OF COOKING SHEETS

Cooking sheets should NEVER:

- Be folded or creased. Be touched with sharp objects.
- Come in contact with griddle scrapers or abrasive pads.
- Be placed under other equipment or objects.

Cooking sheets should ALWAYS:

- Be wiped with a damp soft cotton cloth after each run to remove any product residue.
- Be cleaned after the griddle is shut down for the day.

The time to change a cooking sheet is when:

- Product starts sticking to the sheet.
- Too much carbon build-up causes a product appearance, cooking or taste problem.
- The head surface is cool.
- The sheet is torn or ripped.

⚠ WARNING

THE TOP-SIDE™ COOKING HEAD AND GRIDDLE PLATE ARE HOT - USE PROPER CARE WHEN CHANGING THE COOKING SHEETS.

LEVELING OF COOKING HEAD(S)

The Cooking Heads were leveled at the factory.

NOTE: For best results, level griddle before checking. Adjust legs or stand casters to level griddle.

REMOVAL OF COOKING HEAD

NOTE: To identify parts, refer to page 9.

1. Turn off griddle and disconnect Top-Side™ Cooker electric power.
2. Remove the cooking sheet by lifting off cooking sheet mounting clips.
3. Place a layer of soft cloth and then a layer of cardboard onto griddle plate under cooking head to protect Miraclean® surface.
4. Raise cooking head completely to release tension on cooking head support pin. Remove support pin and its cotter pin and carefully lower cooking head to protected griddle surface.

⚠ WARNING

The cooking head is not supported after the cooking head support pin has been removed. If dropped the weight of the cooking head when unsupported will cause damage to the griddle surface or injury to personnel.

5. Do not turn the support pin in either direction.
6. To reattach the cooking head to the ram lift arm, raise cooking head completely and replace cooking head support pin. Insert a new stainless steel cotter pin to secure support pin, holding support pin to keep it from spinning.
7. Replace cooking sheet. See - "Installing a Cooking Sheet".

SETTING THE OFFSET ON THE THERMOSTAT

1. Turn power off to the Top-Side™ control box.
2. Push and hold (Push to Set) button on the front of the thermostat.
3. Turn power back on to Top-Side™ control box.
4. While holding the (Push to Set) button, turn knob to change the offset number that is displayed.
5. The higher the negative number is, the hotter the Top-Side™ head will be. Turning the knob to a positive number will decrease the temperature of the Top-Side™ head.
6. When you reach the desired number, keep holding the (Push to Set) button until the display starts blinking. Then release the (Push to Set) button. If you release the button before the display starts blinking, you will have to start over at step one.

■ SERVICE DIAGNOSIS

A properly adjusted Keating Top-Side™ Cooker, with no load, will cycle "ON" approximately every 5-1/2 to 6-1/2 minutes. Each cycle will last 40 seconds, ensuring that the temperature setting is held within a narrow range.

TROUBLE SHOOTING

The following diagnosis is only to be used as a guide to qualified service personnel. Keating recommends that you use a qualified & licensed service company. (Equipment still under warranty requires it.) Call 1-800-KEATING if you need assistance in locating a qualified service company.

NOTE: To correctly and quickly diagnose the system, the chart below should be followed in sequential order.

TROUBLE SHOOTING CHART

PROBLEM	PROBABLE CAUSE	SOLUTION
Power On light does not come on	a. No electricity to Top-Side™ Cooker. b. On/Off switch is faulty.	a. Connect Top-Side™ Cooker to an approved source of power. b. Replace On/Off switch.
Element On light does not illuminate and Cooking Head will not heat	a. Connections to thermostat are loose or thermostat is faulty. b. Connections to thermostat temperature probe are loose or probe is faulty. c. Hi-Limit has tripped or Hi-Limit is faulty. NOTE: Hi-Limit is self-resetting. d. Connections to Hi-Limit are loose or Hi-Limit is faulty. e. Connections to contactor are loose or contactor is faulty. f. On/Off switch is faulty.	a. Check connections and tighten where necessary. If thermostat is faulty, replace it. b. Check connections and tighten where necessary. If probe is faulty, replace it. c. Wait until Cooking Head cools down. If Element On light will not come on Hi-Limit if faulty, replace it. d. Check connections and tighten where necessary. e. Check connections and tighten where necessary. If contactor is faulty, replace it. f. Replace On/Off switch.
Element On light does not illuminate but Cooking Head does heat	a. Element On light is faulty.	a. Replace Element On light.
Element On light flashes once whenever power is turned on	a. Thermostat temperature probe or wires have shorted out.	a. Replace probe and/or wires. Use conductive heat paste when installing new probe.
Temperature of Cooking Head is erratic	a. If erratic, thermostat is faulty.	a. Replace thermostat.

TROUBLE SHOOTING THE THERMOSTAT

PROBLEM	PROBABLE CAUSE	SOLUTION
Temperature reading is incorrect, showing a sensor error, (E _c .In) or LOAD LED is switching at the wrong temperature.	a. Sensor or controller may be bad. Sensor connections may be bad. b. Controller is wired incorrectly.	a. Place a jumper wire across the thermocouple input terminals. The display should indicate ambient temperature. If it does, the controller is ok. If not, replace controller. Decrease set point below ambient temperature, LOAD LED should be off for heating controllers. If it is, the controller is OK. Increase set point above ambient temperature. LOAD LED should be on for heating controllers. If it is, the controller is OK. b. Verify proper wiring. Call 1-800-KEATING for a diagram.
Temperature reading is decreasing, but actual temperature is increasing.	a. Thermocouple polarity is reversed. Red wire denotes negative wire. b. Ambient temperature in the control cabinet is above 122°F (50°C).	a. Check thermocouple connections. All connections, including extension wire, must maintain the correct polarity. Correct if needed. b. Measure temperature in cabinet to ensure it is below 122°F (50°C).

INJECTING GREASE THROUGH GREASE FITTING

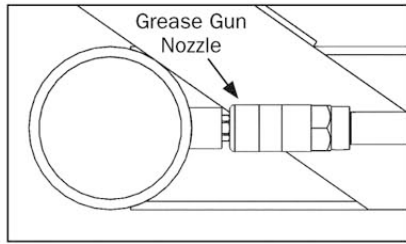

1. Ensure that you are using a food grade grease in a clean grease gun.
2. Clean fitting and nozzle to remove any dirt or debris that may be on surfaces.
3. Firmly push nozzle of grease gun over grease fitting, maintaining pressure to ensure seal throughout greasing process.
4. Squeeze handle of grease gun to inject grease into the assembly.
5. Do not over-grease the assembly, only a light coating is required.
6. Remove nozzle from fitting.
7. Wipe away any excess grease from fitting and any possible overflow that may have occurred.

REPLACING GREASE FITTING

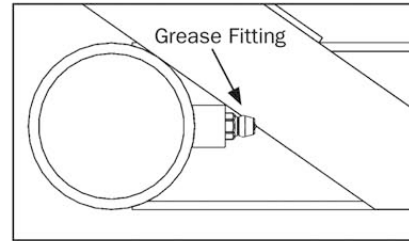

1. Remove current grease fitting using box end wrench or socket of appropriate size to prevent stripping.
2. Carefully clean coupler hole and threads to remove any build-up or old grease remaining.
3. Thread in new grease fitting to coupler.
4. Tighten grease fitting till back face of hex is flush with coupler to eliminate leakage.

■ ORDERING PARTS

Parts may be ordered by calling 1-800-KEATING or your local Keating service company. We recommend using genuine Keating Replacement Parts - engineered and manufactured specifically to meet exact specifications and requirements for Keating equipment.

Refer to the Keating Top-Side™ Cooker Limited Warranty for complete service and ordering information.

The model/serial plate for each cooking head is located on the control panel assembly. The serial and model numbers are necessary when ordering.

WARNING AND OPERATING PLATES

All warning and operating plates on the Keating MIRACLEAN® Electric Griddle should be in place at all times. If plates are damaged or lost, replace them immediately.

MANUAL LIFT TOP-SIDE™ COOKER (EXPLODED VIEW)

Figure 6-1

(See parts list on following page)

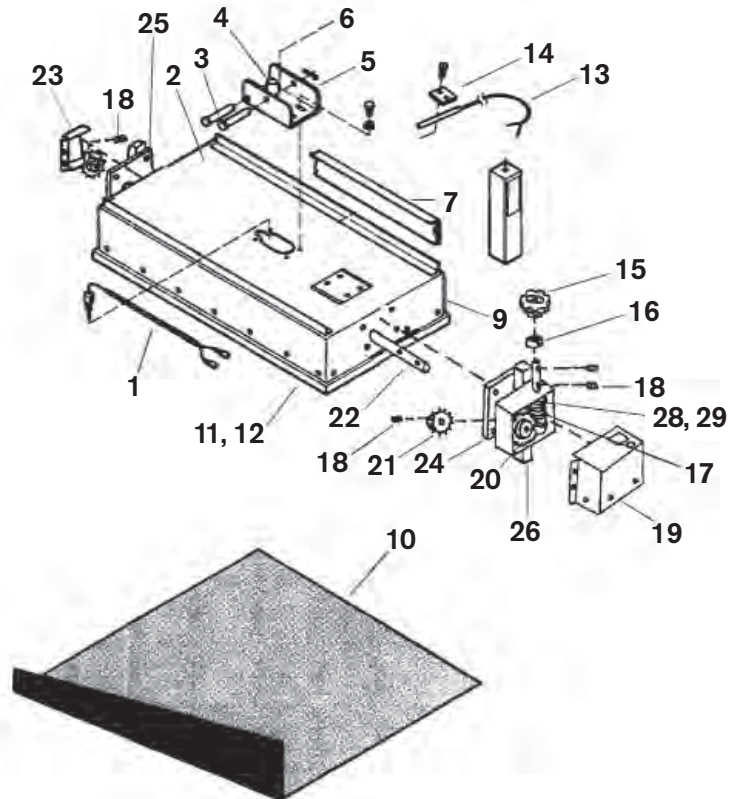
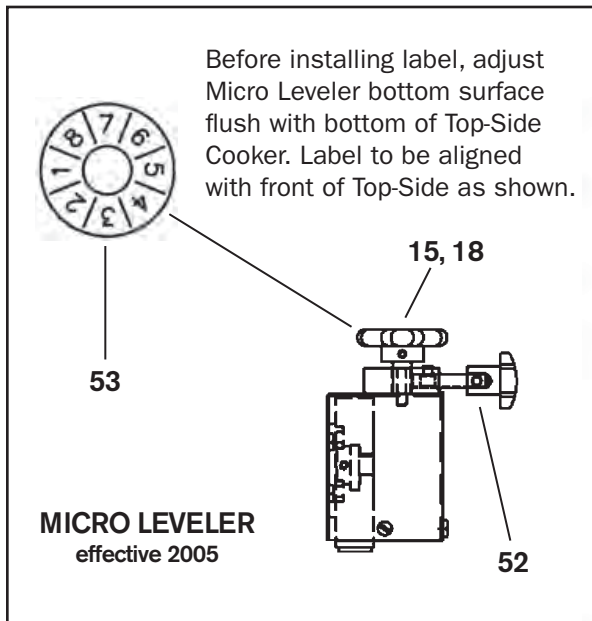
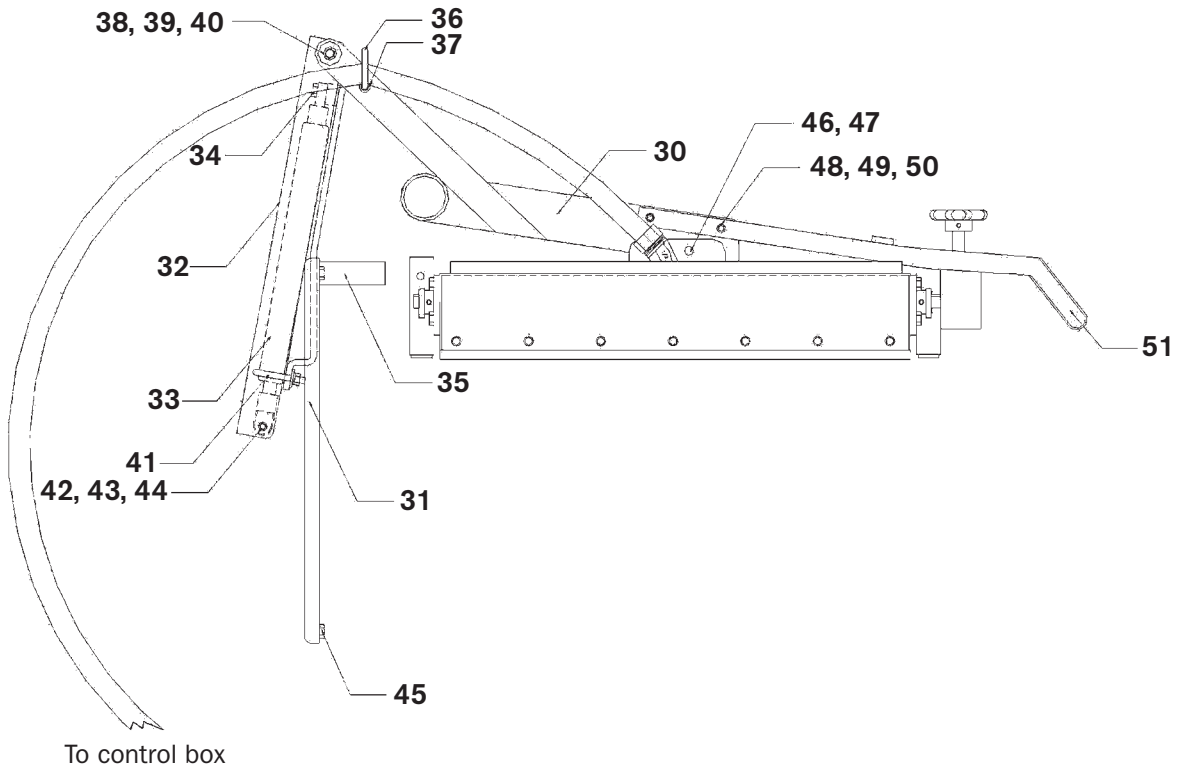

TOP-SIDE™ COOKING HEAD - MANUAL & AUTO-LIFT

See Figure 6-1

ITEM	DESCRIPTION	P/N	QTY
1	THERMOSTAT TEMPERATURE PROBE KIT	016671	1
2	COOKING HEAD (COMPLETE)	1-800-KEATING	1
3	STOP CLEVIS PIN, S/S	015164	1
4	SWIVEL BRACKET WIRE SLEEVE (INCL. IN ITEM 5)	---	1
5	SWIVEL BRACKET	028181	1
6	SWIVEL BRACKET SUPPORT CLEVIS PIN, S/S	015164	1
7	COOKING SHEET MOUNTING CLIP	017316	2
9	COVER (for TSC with MICRO LEVELER)	1-800-KEATING	1
10	COOKING SHEET (SINGLE SHEET)	038492	
	COOKING SHEET (PACKAGE OF 12)	038522	
11	MIRACLEAN® COOKING FACE PLATE	---	1
12	HEATING ELEMENT 4KW, 220V (NOT SHOWN)	056510	1
	HEATING ELEMENT 480V, 4000W (NOT SHOWN)	035664	1
	INSULATION BOARD (NOT SHOWN)	016503	2
13	HIGH LIMIT PROBE	015173	1
14	HIGH LIMIT PROBE MOUNTING PLATE	014247	1
15	KNOB	028622	1
16	COLLAR	028486	2
17	WORM GEAR	028487	1
18	1/4-20 x 1/4" ALLEN SET SCREW	028501	4
19	HOUSING COVER	---	1
20	WORM GEAR WHEEL	028488	1
21	SPUR GEAR	030241	2
22	SHAFT	028461	1
23	REAR COVER	---	1
24	FRONT HOUSING	---	1
25	REAR HOUSING	---	1
26	FRONT PLUNGER	028521	1
27	REAR PLUNGER (NOT SHOWN)	028522	1
28	TEFLON WASHER (NOT SHOWN)	028490	1
29	FIBER WASHER (NOT SHOWN)	028500	2
30	TOP-SIDE COOKER WELD. MANUAL	052114	1
31	TOP-SIDE COOKER SPRING SUPPORT WELDMENT	052266	1
32	MANUAL TOP-SIDE GAS SPRING LIFT	052251	1
33	MANUAL TOP-SIDE COOKER GAS SPRING	054444	1
34	SCREW 5/16-18 x 3/4 HEX HEAD ZINC PLATED	015262	1
35	TOP-SIDE COOKER SUPPORT BRACE GAS	052269	1
36	TOP-SIDE CONDUIT SUPPORT	052287	1
37	NUT RIVET 1/4-20 x 5/8 0.332 BODY	030269	1
38	WASHER 1/4 ID x 7/8 OD x 1/16 THK NICKEL	015414	2
39	SCREW 1/4-20 x 3/4 SERRATED FLANGE LOCK	032328	6
40	TOP-SIDE COOKER LIFT ARM ROD	052117	1
41	U BOLT WITH MOUNTING PLATE	052286	1
42	SCREW 10-24 x 3/8 SERRATED FLANGE LOCK	032327	2
43	WASHER 0.190 ID x 0.5630 D x 0.047 THK NICKEL	013217	2
44	MANUAL TOP-SIDE COOKER GAS SPRING ROD	052252	1
45	NUT 1/4-20 HEX NICKEL PLATED	016383	1
46	3/8-2 1/2 CLEVIS PIN	015164	2
47	COTTER KEYS S.S.	015166	2
48	1/4-20 x 3 THREADED ROD	014226	2
49	1/4 STAR WASHER	017046	4
50	1/4-20 ACORN NUT	015227	4
51	WELDMENT HANDLE GEAR GAPPING SYSTEM	027311	1
52	TOP-SIDE MICRO LEVELER ASSEMBLY	056035	1
53	TOP-SIDE MICRO LEVELER LABEL	057432	1

AUTO-LIFT TOP-SIDE™ COOKER

Figure 6-2

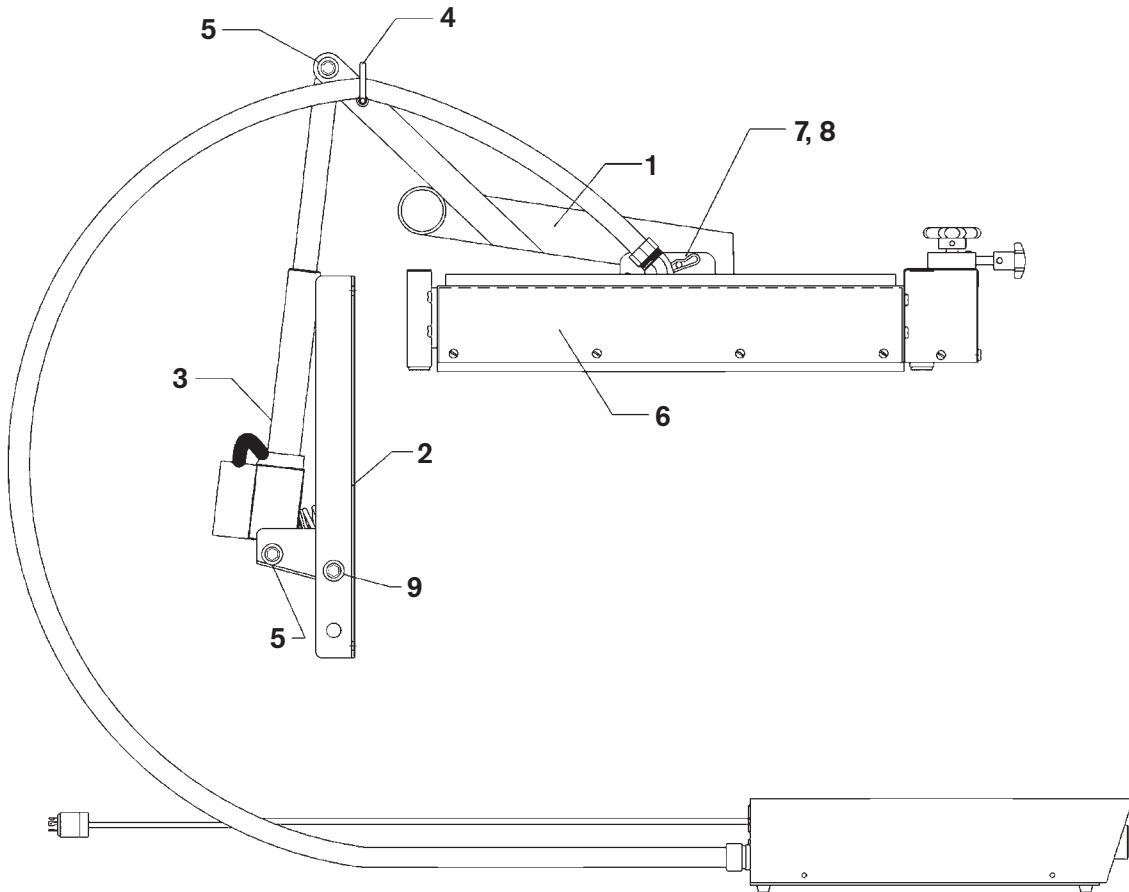

ITEM	DESCRIPTION	P/N	QTY
1	TOP-SIDE COOKER WELD. AUTO NEW ARM	052115	1
2	AUTO TOP-SIDE A0-2 ACTUATOR MTG.	053991	1
3	ACTUATOR AUTO TOP-SIDE COOKER 24V	060463	1
4	TOP-SIDE CONDUIT SUPPORT	052287	1
5	TOP-SIDE COOKER LIFT ARM ROD	052117	2
6	TOP-SIDE COOKER HEAD W/ CONDUIT AND CONTROL PANEL	---	1
7	3/8 - 2 1/2 CLEVIS PIN	015164	1
8	COTTER PIN 5/16 - 3/8 : 0.72 WIRE	015165	2
9	TOP-SIDE COOKER LIFT ARM ROD	052591	1

INSTRUCTIONS FOR MICROSWITCH ADJUSTMENT AUTO-LIFT TOP-SIDE™ ACTUATOR

See Figure 6-3

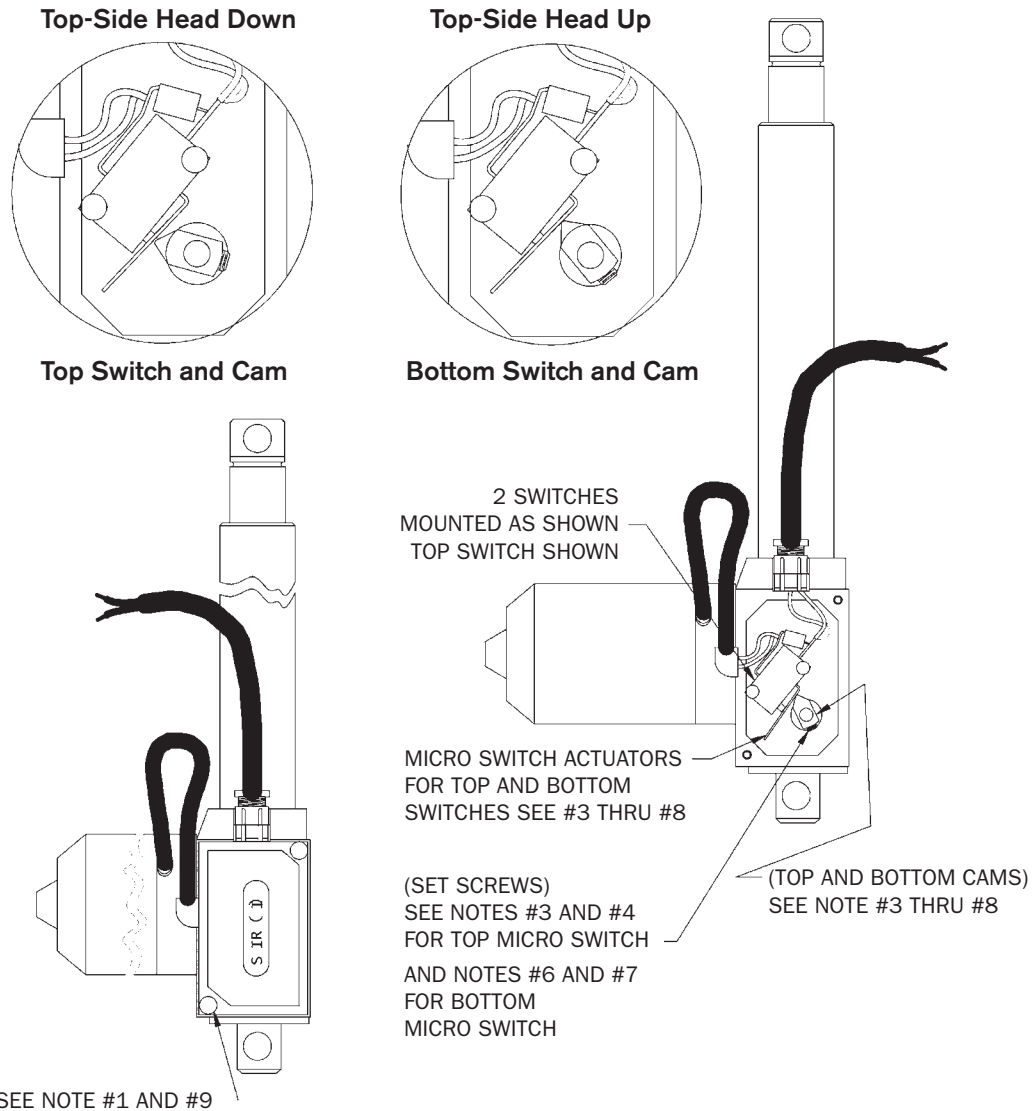

1. Remove the limit switch black plastic cover on the actuator.
2. Turn on the power on unit and push the T1, T2 or T3 button on the timer. The actuator will extend the stroke and lower head. The motor must stop and the stroke should stop extending before it reaches its mechanical stop. This movement is controlled by the top micro switch.
3. If the motor fails to stop, manually depress the top micro switch actuator. Disconnect power to the actuator motor. Loosen the set screw (2.5mm allen wrench) located on the top cam. Rotate the top cam clockwise, until the switch is made (listen for audible click).
4. Tighten the set screw on the cam, using blue locktite.
5. Turn on the power and push the T1, T2 or T3 button on the timer until it goes to the preset time. The actuator will retract the stroke and raise the head. The motor

must stop and the stroke should stop retracting before it reaches its mechanical stop. This movement is controlled by the bottom micro switch.

6. If the motor fails to stop, manually depress the bottom micro switch actuator. This will disconnect power to the actuator motor. Loosen the set screw (2.5mm Allen wrench) located on the bottom cam. Rotate the bottom cam counter clockwise until the switch is made (listen for audible click).
7. Tighten the set screw on the cam, using blue locktite.
8. Test the Top-Side head. Verify the adjustments did not change the length of the stroke, thus preventing correct function of the top Top-Side head. The Top-Side cooking head must be able to reach the griddle plate. If it does not function properly, complete steps #2 through #7.
9. Reinstall the switch cover.

TOP-SIDE™ COOKER CONTROL PANEL

Figure 6-4

ITEM	DESCRIPTION	P/N	QTY
1	THERMOSTAT	056840	1
	THERMOSTAT REPLACEMENT KIT for PRE 2005 MODELS	057138	1
2	HI-LIMIT CONTROL	010311	1
3	HI-LIMIT MOUNTING BRACKET	016654	1
4	CONTACTOR, 50A, 3 POLE	038362	1
5	ROCKER SWITCH, WHITE, ON/OFF	035030	1
6	INSTRUCTION PLATE ON/OFF SWITCH PLATE	016672	1
7	INDICATING LIGHT, ELEMENT ON, RED 250V	036933	1
	INDICATING LIGHT, ROUND RED 220V (Effective 8/31/10)	002495	1
8	INSTRUCTION PLATE ELEMENT ON LIGHT PLATE	016673	1
9	TERMINAL BLOCK 3 POLE	002565	1
10	CORD 9' 12/3 SJO	018480	1
11	GROUND LUG 1/4"	028510	1
12	CONDUIT 65" COMPLETE WITH WIRES	034431	1
13	CONNECTOR 1/2" LIQUID TIGHT 45°	031584	1
14	CONNECTOR 1/2" LIQUID TIGHT STRAIGHT	031586	1
15	PLUG 30 AMP 250V 3W 2 POLE	020068	1
16	TOGGLE SWITCH SEALED, ON/OFF	059141	1

Top View with Cover Removed

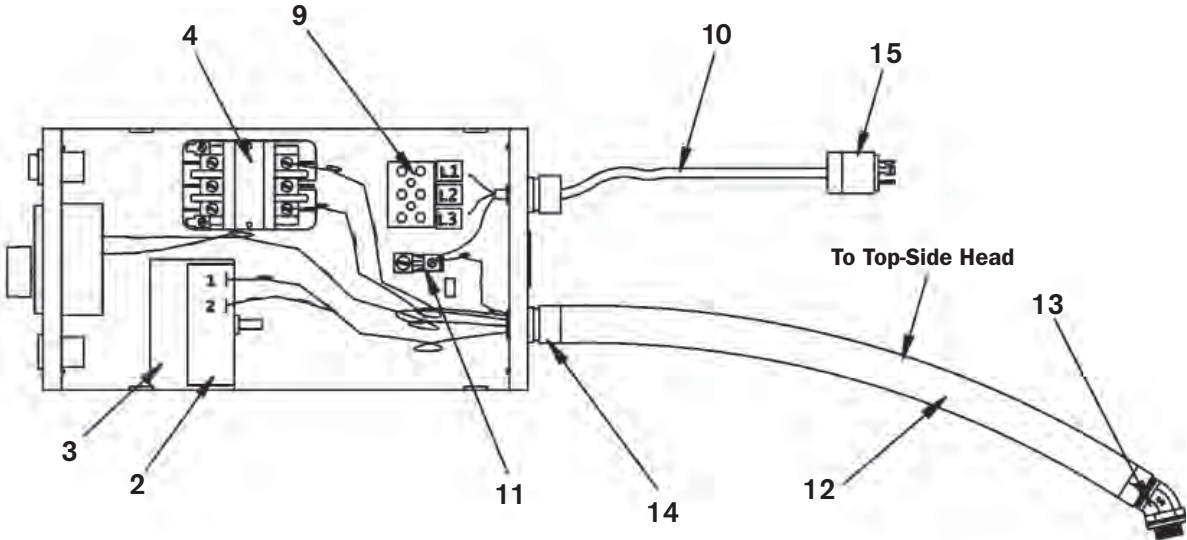

Front View

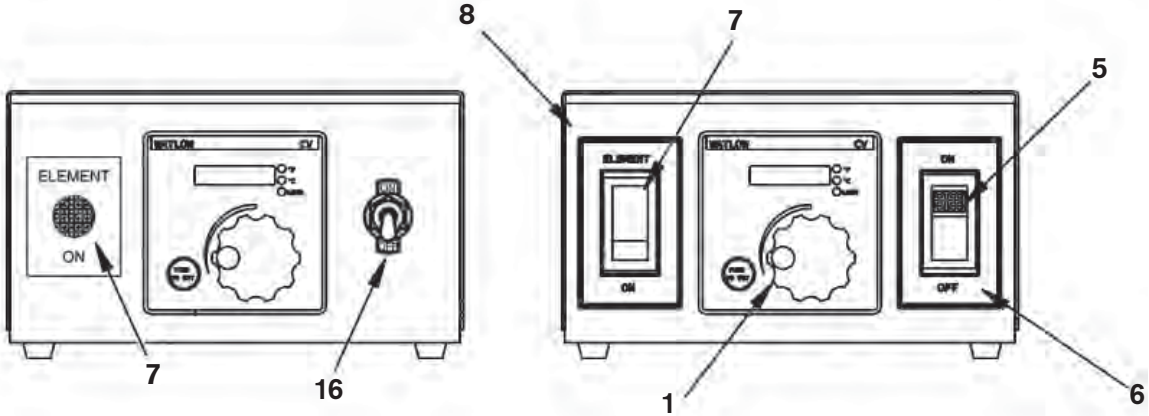

TOP-SIDE™ COOKER POWER SUPPLY BOX FOR AUTO-LIFT ACTUATORS WITH DIGITAL TIMER - 120VAC SUPPLY

Figure 6-5

ITEM	DESCRIPTION	P/N	QTY
1	TRANSFORMER STEPDOWN 24VAC 75VA	056037	1
2	RELAY DPDT 24VAC	030844	1
3	RECTIFIER 24VDC	038367	1
4	CIRCUIT BREAKER 3A 1 POLE 250V	053338	1
5	CORD POWER 6'	006315	1

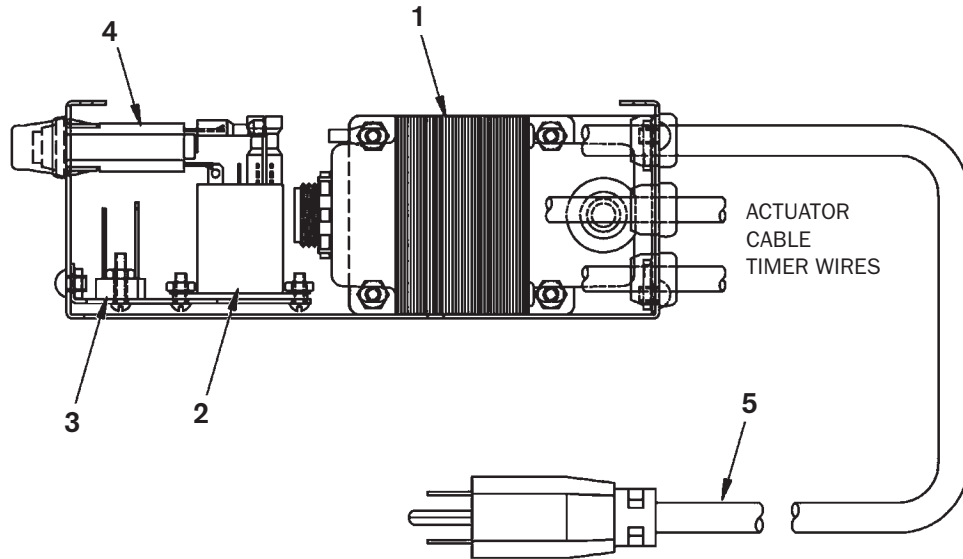

WIRING DIAGRAM

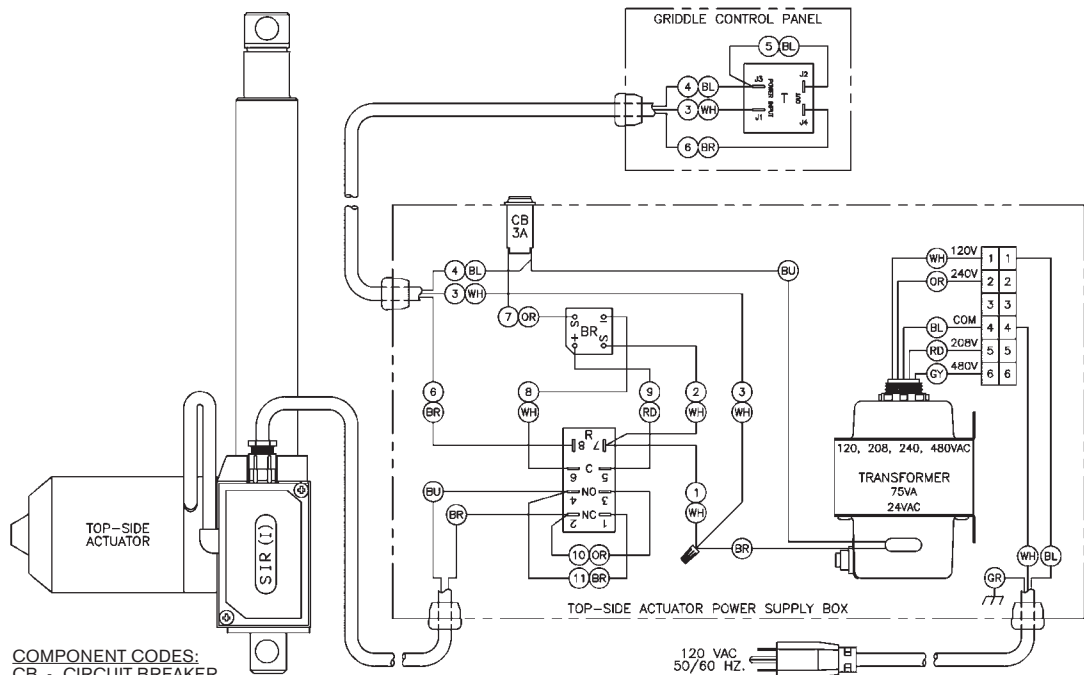

WIRE COLOR CODES:

- RD - RED
- BL - BLACK
- BR - BROWN
- BU - BLUE
- GR - GREEN
- GY - GRAY
- OR - ORANGE
- WH - WHITE

COMPONENT CODES:

- CB - CIRCUIT BREAKER
- BR - BRIDGE RECTIFIER
- R - RELAY 24 VAC
- T - TIMER

NOTE: ALL WIRES ARE 18 AWG

TOP-SIDE™ COOKER POWER SUPPLY BOX FOR AUTO-LIFT ACTUATORS WITH DIGITAL TIMER - 240VAC SUPPLY

Figure 6-6

ITEM	DESCRIPTION	P/N	QTY
1	TRANSFORMER STEPDOWN 24VAC 75VA	056037	1
2	RELAY DPDT 24VAC	030844	1
3	RECTIFIER 24VDC	038367	1
4	CIRCUIT BREAKER 3A 1 POLE 250V	053338	1
5	CORD POWER 9' 220V	020833	1
6	RUBBER BOOT FOR CIRCUIT BREAKER	054664	

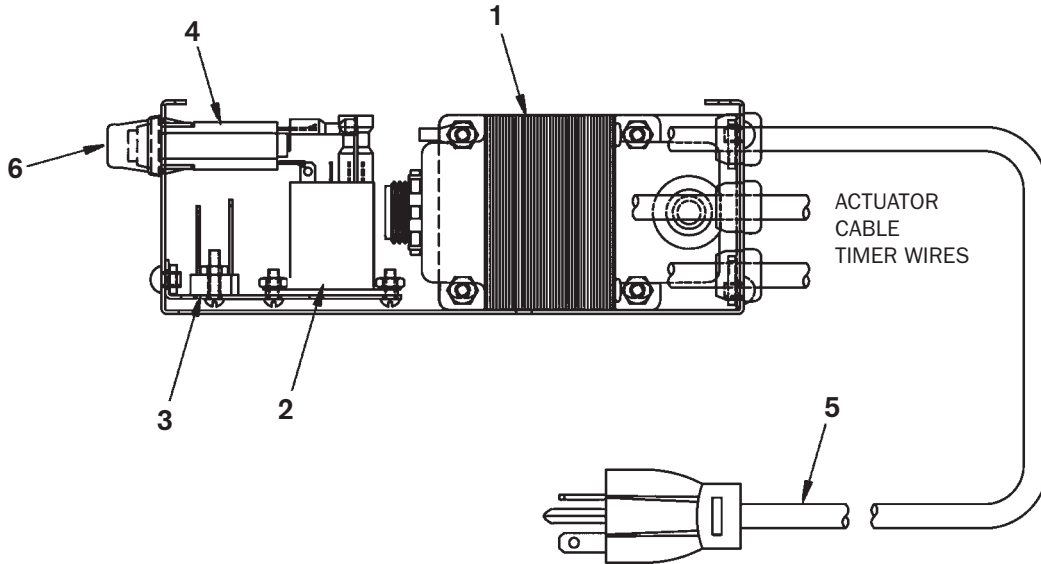

WIRING DIAGRAM

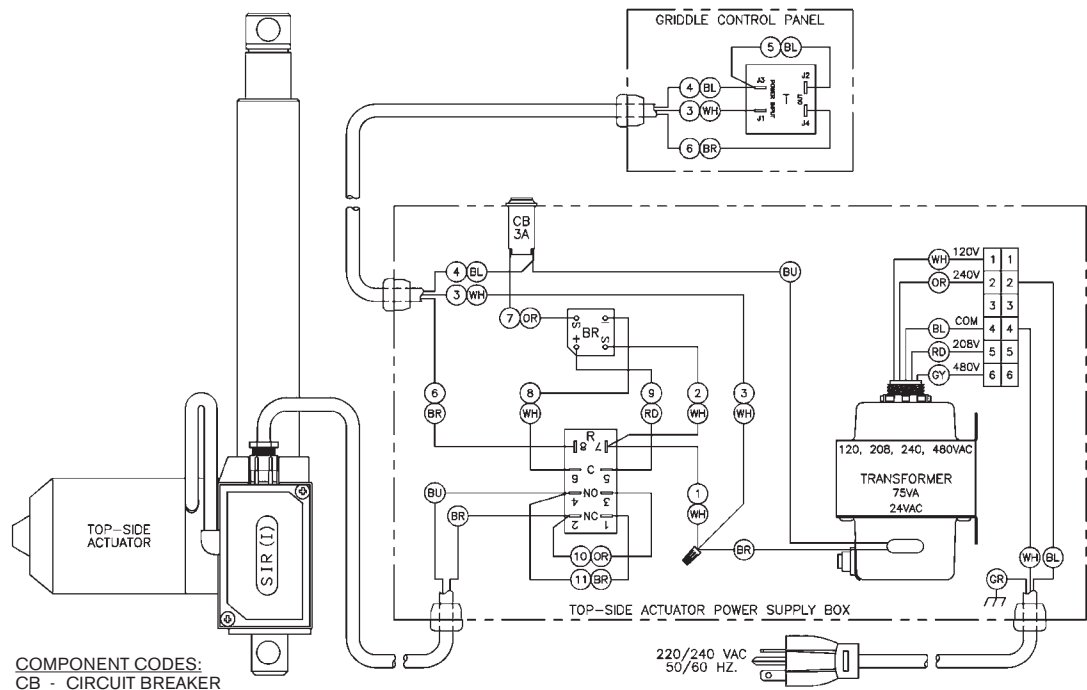

WIRE COLOR CODES:
 RD - RED
 BL - BLACK
 BR - BROWN
 BU - BLUE
 GR - GREEN
 GY - GRAY
 OR - ORANGE
 WH - WHITE

COMPONENT CODES:
 CB - CIRCUIT BREAKER
 BR - BRIDGE RECTIFIER
 R - RELAY 24 VAC
 T - TIMER

NOTE: ALL WIRES ARE 18 AWG

■ WIRING DIAGRAM

TOP-SIDE COOKER MANUAL LIFT WIRING DIAGRAM

Figure 6-7

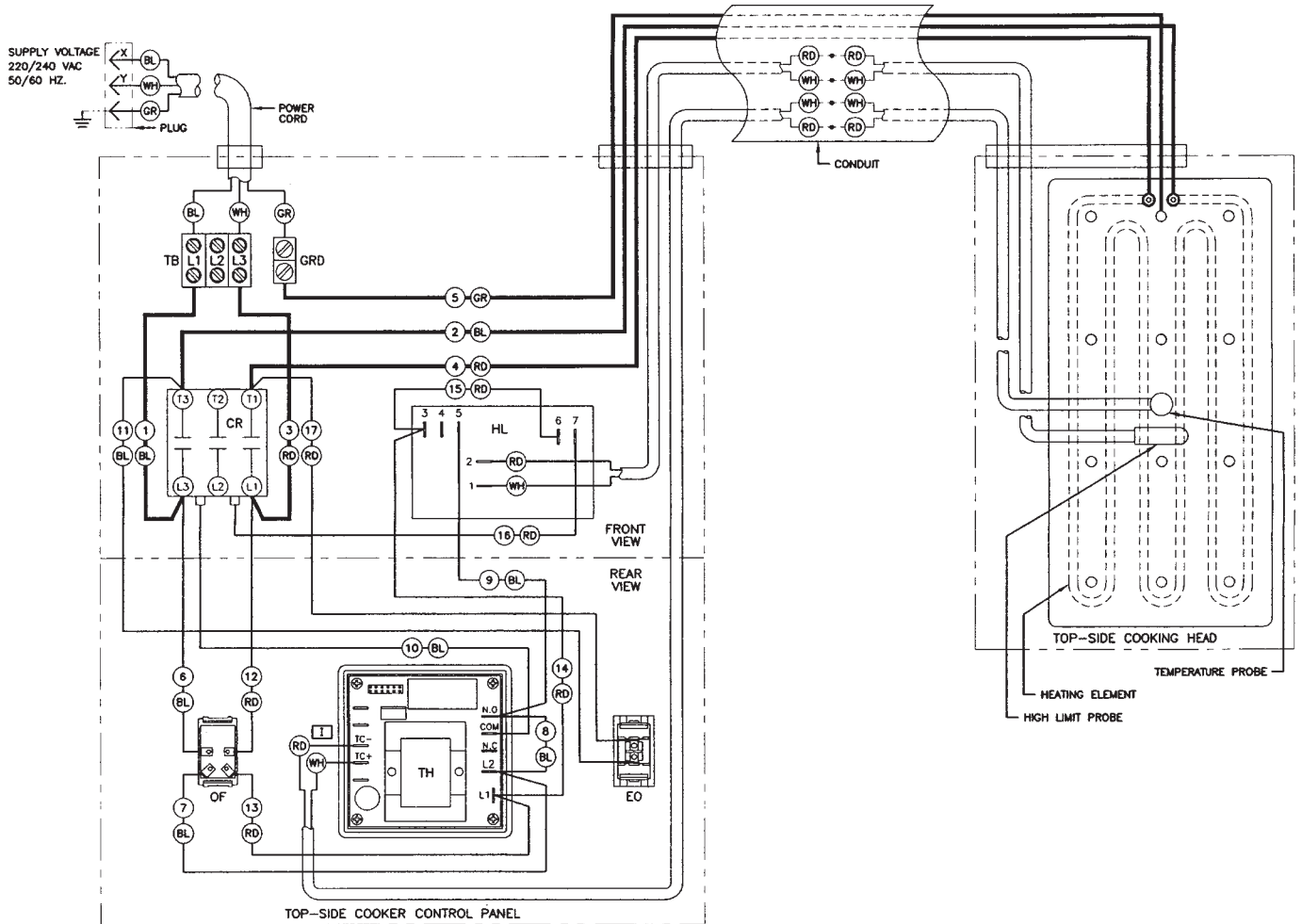

LIGHTED ROCKER ON/OFF SWITCH GREEN LIGHT ON TOP **OR** LIGHTED ROCKER ON/OFF SWITCH GREEN LIGHT ON BOTTOM

NOTE: ANGLED TERMINALS OF SWITCH ARE **ALWAYS** TOWARD CONTROL PANEL BOTTOM.

NOTES:

1. **1** = 12 AWG WIRE
2. ALL OTHER WIRES ARE 18 AWG

COMPONENT CODES:

- CR - CONTACTOR 220/240VAC
- EO - "ELEMENT ON" LIGHT (RED)
- GND - GROUNDING LUG
- HL - HIGH LIMIT
- OF - "ON/OFF" SWITCH, LIGHTED (GREEN)
- R - RELAY
- TB - TERMINAL BLOCK
- TH - THERMOSTAT

WIRE COLOR CODES:

- BL - BLACK
- GR - GREEN
- RD - RED
- WH - WHITE

■ WIRING DIAGRAM

TOP-SIDE™ COOKER AUTO-LIFT WIRING DIAGRAM FOR GAS GRIDDLE

Figure 6-8

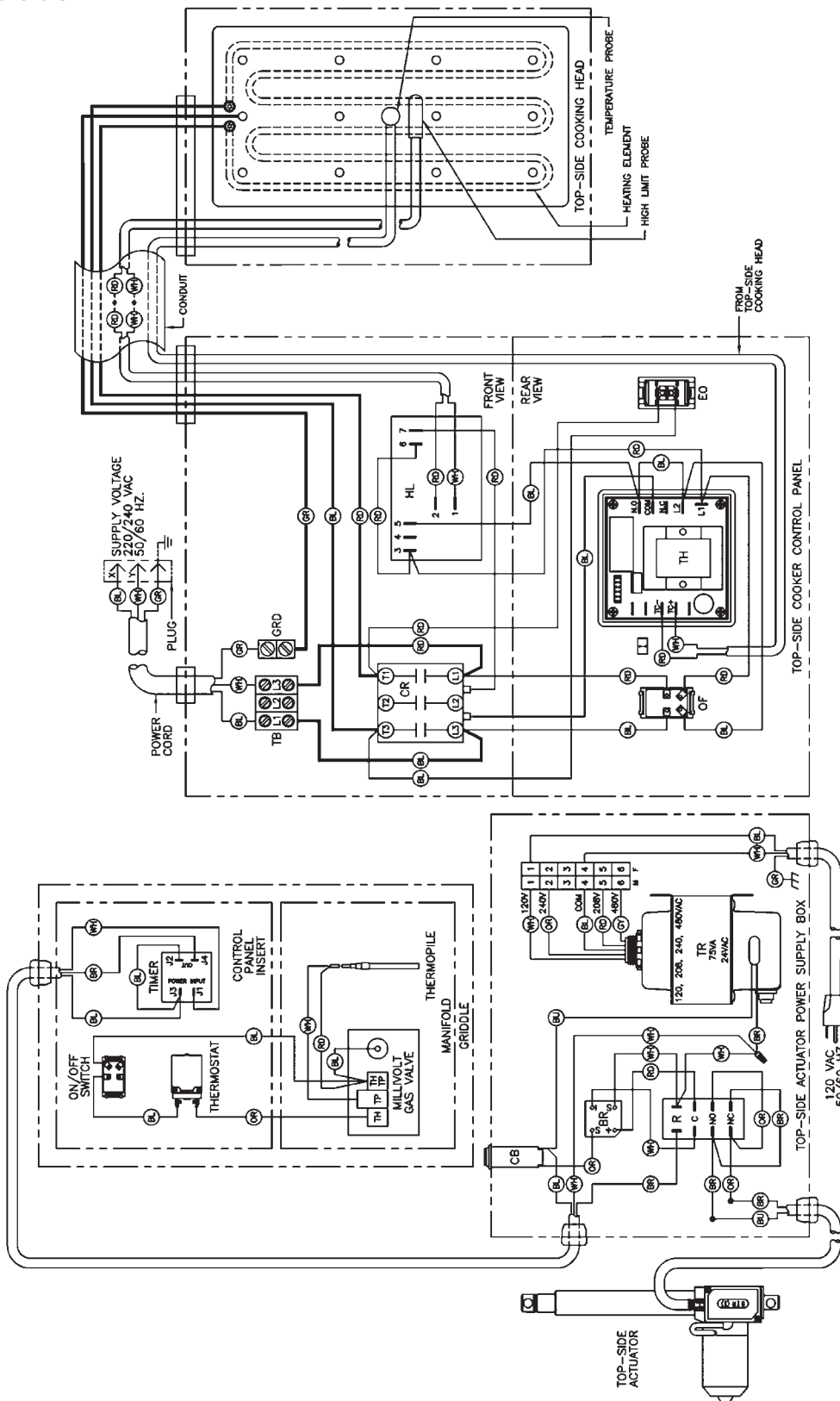

<p>COMPONENT CODES:</p> <p>BR - BRIDGE RECTIFIER</p> <p>CB - CIRCUIT BREAKER</p> <p>CR - CONTACTOR 220/240VAC</p> <p>EO - "ELEMENT ON" LIGHT (RED)</p> <p>GRD - GROUNDING LUG</p> <p>HL - HIGH LIMIT</p>		<p>WIRE COLOR CODES:</p> <p>BL - BLACK RD - RED</p> <p>GR - GREEN WH - WHITE</p> <p>GY - GRAY BR - BROWN</p> <p>OR - ORANGE BU - BLUE</p>	
<p>NOTES:</p> <p>1. = 12 AWG WIRE.</p> <p>2. ALL OTHER WIRE ARE 18 AWG</p>		<p>120 VAC 50/60 HZ.</p>	

■ WIRING DIAGRAM

TOP-SIDE COOKER AUTO-LIFT WIRING DIAGRAM FOR ELECTRIC GRIDDLE 208 - 240VOLT

Figure 6-9

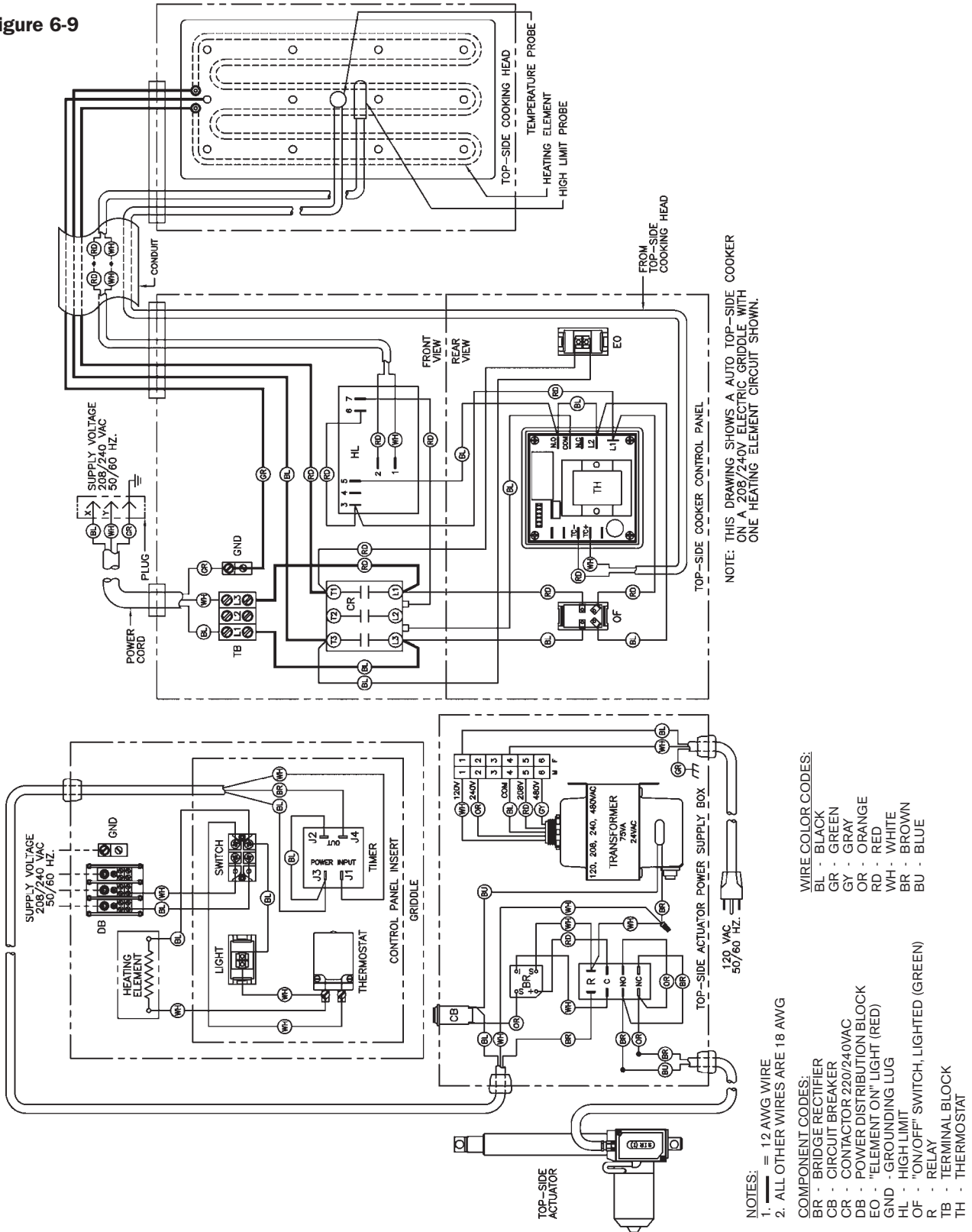

WIRE COLOR CODES:
 BL - BLACK
 GR - GREEN
 GY - GRAY
 OR - ORANGE
 RD - RED
 WH - WHITE
 BR - BROWN
 BU - BLUE

- NOTES:
 1. — = 12 AWG WIRE
 2. ALL OTHER WIRES ARE 18 AWG
- COMPONENT CODES:
 BR - BRIDGE RECTIFIER
 CB - CIRCUIT BREAKER
 CR - CONTACTOR 220/240VAC
 DB - POWER DISTRIBUTION BLOCK
 EO - "ELEMENT ON" LIGHT (RED)
 GND - GROUNDING LUG
 HL - HIGH LIMIT
 OF - "ON/OFF" SWITCH, LIGHTED (GREEN)
 R - RELAY
 TB - TERMINAL BLOCK
 TH - THERMOSTAT

■ WIRING DIAGRAM
TOP-SIDE™ COOKER AUTO-LIFT WIRING DIAGRAM
FOR ELECTRIC GRIDDLE 480VOLT

Figure 6-10

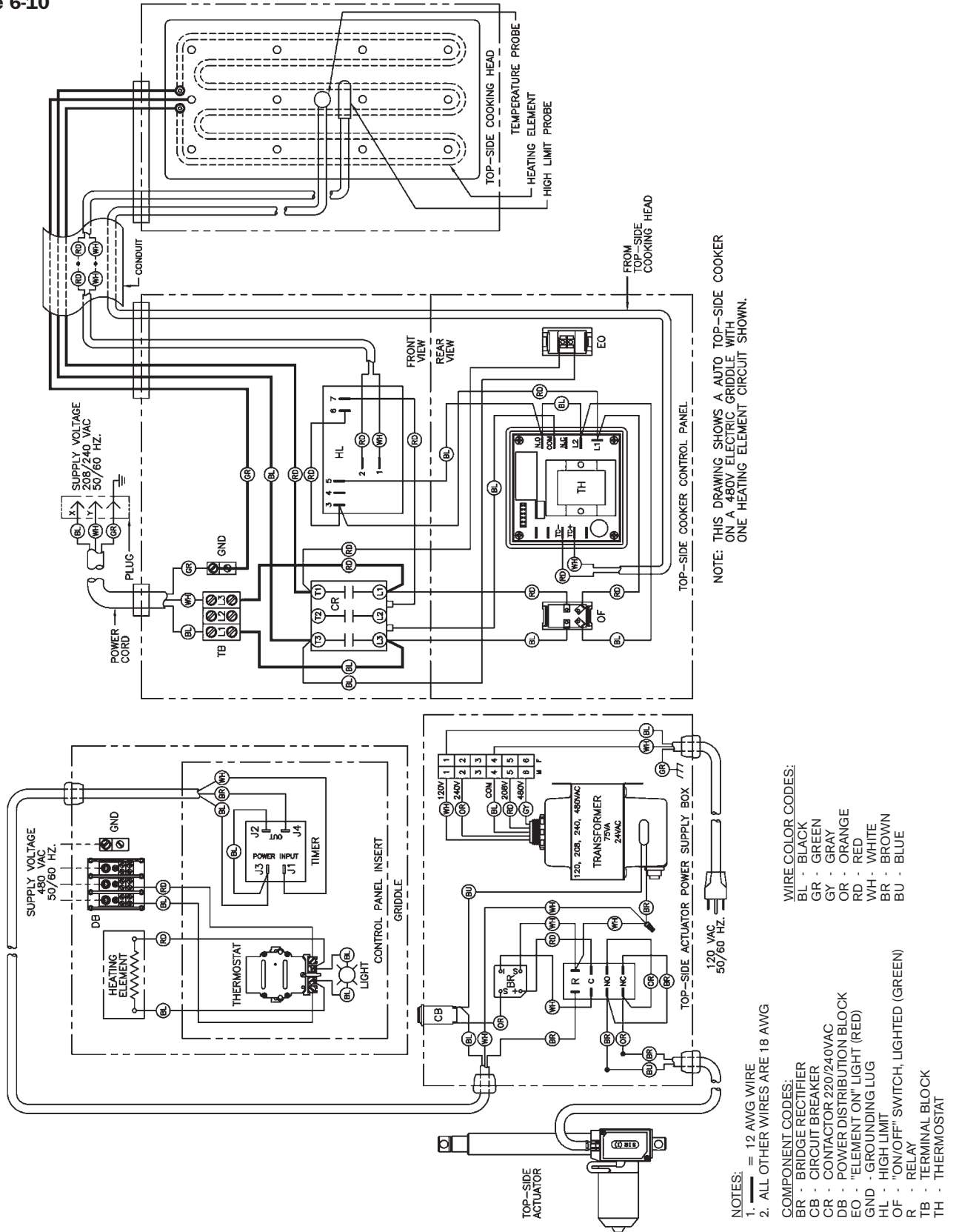



WARRANTY

LIMITED WARRANTY

Keating of Chicago, Inc. ("Keating") warrants to the original purchaser, ("Customer"), all new Keating Fryers, Filter Systems, Griddles, Keep Krisp[®], Custom Pasta Systems, Top-Side[™] Cookers, Computer Timers, Fryer & Pasta Vessels and Keating replacement parts ("products") installed after June 1, 1994 to be free of defects in material or workmanship, subject to the following terms and conditions.

LENGTH OF WARRANTY

All products other than Fryer & Pasta Vessels and replacement parts shall be warranted for a period of one year from the date of original equipment installation. Keating replacement parts are warranted for a period of ninety days from the date of installation. Fryer & Pasta Vessels are warranted as described below.

FRYER & PASTA VESSEL WARRANTY

Fryers purchased after June 1, 1994 carry a prorated vessel warranty on defects in materials or workmanship to the Customer based on the following scale:

Time from Installation Date	Fryer Vessel Warranty Credit
13-60 months	100%
61-72 months	80%
73-84 months	60%
85-96 months	40%
97-108 months	20%
109-120 months	10%

The credit for the defective fryer & pasta vessel shall be applied against the cost of the replacement vessel, utilizing Keating's then current price, upon return of the vessel to Keating only during the first 60 months, subject to the limitations described below.

LIMITATIONS OF LIABILITY

In the event of warranty claim or otherwise, the sole obligation of Keating shall be the repair and / or replacement at the option of Keating of the product or component part thereof. Such repair or replacement shall be at the expense of Keating except that the Customer shall pay the following expenses: all freight and labor expense for Keating replacement parts; for all other products, mileage exceeding 50 miles or travel more than one hour, labor costs of more than one person, overtime rates, truck charges, difference between ground and other mode of transportation, and holiday charges. Any repair or replacement under this Limited Warranty does not constitute an extension of the original warranty for any period for the product or for any component or part thereof. Parts to be replaced under this Limited Warranty will be repaired at the option of Keating with new or functionally operative parts. Keep Krisps and Computer Timers must be returned to Keating for warranty repair or replacement. Field repairs of those items are not authorized.

THE LIABILITY OF KEATING ON ANY CLAIM OF ANY KIND, INCLUDING CLAIMS BASED ON WARRANTY, EXPRESSED OR IMPLIED, CONTRACT, NEGLIGENCE, STRICT LIABILITY OR ANY OTHER THEORIES SHALL BE SOLELY AND EXCLUSIVELY THE REPAIR OR REPLACEMENT OF THE PRODUCT AS STATED HEREIN, AND SUCH LIABILITY SHALL NOT INCLUDE, AND CUSTOMER SPECIFICALLY RENOUNCES ANY RIGHTS TO RECOVER, SPECIAL, INCIDENTAL, CONSEQUENTIAL OR OTHER INJURIES TO PERSONS OR DAMAGE TO PROPERTY, LOSS OF PROFITS OR ANTICIPATED PROFITS, OR LOSS OF USE OF THE PRODUCT.

If any oral statements have been made regarding the Keating products, such statements do not constitute warranties and are not part of the contract sale. This Limited Warranty constitutes the complete, final and exclusive statement with regard to warranties.

THIS LIMITED WARRANTY IS EXCLUSIVE AND IS IN LIEU OF ALL OTHER WARRANTIES WHETHER WRITTEN, ORAL, STATUTORY OR IMPLIED, INCLUDING BUT NOT LIMITED TO ANY WARRANTY OF MERCHANTABILITY OR FITNESS FOR PARTICULAR PURPOSE OR WARRANTY AGAINST LATENT DEFECTS.

EXCLUSIONS

The warranties provided by Keating of Chicago, Inc. do not apply in the following instances:

1. Defects arising out of or resulting from improper installation or maintenance, abuse, misuse, modification or alteration by unauthorized service personnel, or any other condition not attributable to a defect in material or workmanship. Proper installation and maintenance are the responsibility of the installer and Customer, respectively. Proper installation and maintenance procedures are prescribed by the Keating Service Manual.
2. In the event that the product was damaged after leaving the factory due to flood, fire, other acts of God or accident, damaged during shipment should be reported to the carrier and is not the responsibility of Keating.
3. In the event the serial number or rating plate has been removed from the product or altered.
4. On parts which would normally be worn or replaced under normal conditions, including but not limited to electric bulbs, fuses, interior and exterior finishes, gaskets and radiants.
5. With regard to adjustments and calibrations such as leveling, tightening of fasteners or plumbing connections, improper gas pressure or improper electrical supply, the checking of and changes in adjustment and calibrations are the responsibility of the installer. Proper installation procedures are prescribed by the Keating Service Manual.
6. In the event of unauthorized repairs or alterations to the Keating product.
7. With the use of sodium chloride in pasta vessels or harsh chemicals in fryer or pasta vessels.
8. Installation in Household.

OTHER TERMS AND CONDITIONS

The Customer must provide proof of purchase from Keating.

This Limited Warranty is valid in the 50 United States, its territories, and Canada, and is void elsewhere. Keating products are sold for commercial use only. If any Keating product is sold as a component of another product or used as a consumer product, such Keating product is sold As Is without any warranty.

If any provision of this Limited Warranty is held to be unenforceable under the law of any jurisdiction, such provision shall be inapplicable in such jurisdiction, and the remainder of the warranty shall remain unaffected. Further in such event, the maximum exclusion or limitation allowable under applicable law shall be deemed substituted for the unenforceable provision.

This Limited Warranty shall be governed by and construed in accordance with the laws of the State of Illinois.

TO SECURE WARRANTY SERVICE

All repair services under this Limited Warranty must be authorized by Keating or performed at Keating. Authorization may be obtained by calling 1-800-KEATING within the Continental United States, Alaska, Hawaii, Puerto Rico and Canada during normal business hours (8 a.m. through 5 p.m. Central Time, Monday through Friday). When calling, please have the following information available: (1) name, address and telephone number of the Customer; (2) location of product, if different; (3) name, model number and serial number of the product; (4) installation date; and (5) description of defect. Keating will then issue a service authorization work order number to one of its approved independent servicing organizations, or request the product or part be shipped to Keating for repair or replacement, as appropriate. Any defective part subject to a claim under this Limited Warranty must be shipped freight prepaid to Keating for testing and examination. Keating's decision as to the cause and nature of any defect under this Limited Warranty shall be final.

■ **SERVICE INFORMATION:**

If you have a service related question call **1-800-KEATING**.
Please state the nature of the call; it will ensure speaking with the appropriate person.

Have your serial and model number available when ordering parts.

As continuous product improvement occurs, specifications may be changed without notice.

.....
KEATING LIMITED WARRANTY CARD

PLEASE COMPLETE AND MAIL AT ONCE--WARRANTY IS NOT IN EFFECT UNTIL CARD IS RETURNED, OR COMPLETE THE WARRANTY CARD ON OUR WEBSITE FOR YOUR CONVENIENCE.

COMPANY: _____

ADDRESS: _____

CITY: _____ STATE: _____ ZIP CODE: _____

DEALER NAME: _____

DATE OF PURCHASE: _____ INVOICE #: _____

SERIAL #: _____ MODEL: _____

FRYER GRIDDLE CUSTOM PASTA
 FILTER SYSTEM TOP-SIDE COOKER HOTPLATE

I HAVE READ THE INSTALLATION AND OPERATING INSTRUCTIONS.

SIGNED: _____ DATE: _____



KEATING OF CHICAGO, INC.
8901 West 50th Street
McCook, IL 60525-6001

1-800-KEATING
PHONE: 708-246-3000
FAX: 708-246-3100

Serving Those Who Serve the Very Best®