



SAFE & EASY[®] FILTER

MANUAL

■ **IMPORTANT:**

THIS MANUAL PROVIDES SPECIFIC OPERATING INSTRUCTIONS FOR YOUR MODEL. USE THE KEATING SAFE & EASY[®] FILTER ONLY AS INSTRUCTED IN THIS MANUAL.

KEEP A COPY OF YOUR BILL OF SALE.

The date on the bill establishes the warranty period should service be required. If service is performed, it is in your interest to obtain and keep all receipts.

KEEP THIS MANUAL FOR TRAINING NEW PERSONNEL.

Record the Serial number and Model number of this Safe & Easy[®] Filter in the spaces provided. **Keep these numbers for future reference.**

SERIAL NUMBER

MODEL NUMBER

Keating commercial filters are not intended for household use.

As continuous product improvement occurs, specifications may be changed without notice.

1-800-KEATING | keatingofchicago.com

⚠ CAUTION

HOT FLUID. DO NOT FILL BEYOND MAXIMUM FILL LINE LOCATED IN THE FRYER VESSEL.



■ TABLE OF CONTENTS

INTRODUCTION	1	CLEAN UP	4
Damage During Shipment	1	Instructions	4
OPERATING INSTRUCTIONS	1	Drain Valve Handle Placement.....	4
PREPARING THE FILTER DRAWER	2	DISCARDING THE OIL	4
Removing the Filter.....	2	Preparing the Filter	4
Installing Components	2	Connecting the Discard Hose	4
Connecting the Tub.....	2	Instructions	4
Connecting the Filter Assembly.....	2	Filter Side View	4
PREPARING THE OIL FOR FILTRATION	3	QUICK HINTS	5
Oil Temperature	3	Do's and Don'ts	5
Removing the Screen.....	3	SERVICE DIAGNOSIS	6
FILTRATION	3	Trouble Shooting Chart	6 - 7
Draining Oil.....	3	Preventative Maintenance	7
Returning the Oil	3	Warranty Repairs	7
Rinsing the Fryer	3	SERVICE PARTS ORDERING	7
		PARTS LIST	8
		WIRING DIAGRAM	9
		WARRANTY INFORMATION	10

■ INTRODUCTION

Instructions in this manual should be read thoroughly before attempting to operate the Safe & Easy® Filter. All installation and service on Keating equipment must be performed by qualified, certified, licensed and/or authorized installation or service personnel.

Operating information for Keating equipment has been prepared for use by qualified and/or authorized personnel.

Keating equipment is made in the USA and has American sizes of hardware. All metric conversions are approximate.

■ OPERATING INSTRUCTIONS

Proper installation will assure top performance. Alterations of any kind to your equipment will void the warranty. Before uncrating, check equipment carefully for damage.

IF EQUIPMENT ARRIVES DAMAGED

Keating does not assume responsibility for loss or damage incurred in transit.

IMPORTANT

This merchandise has been thoroughly inspected and carefully packed before leaving our plant. Responsibility for its safe delivery was assumed by the carrier at the time of shipment. Claims for loss or damage to the contents should, therefore, be made upon the carrier, as follows:

CONCEALED LOSS OR DAMAGE

Concealed loss or damage means loss or damage which does not become apparent until the merchandise has been unpacked. The contents may be damaged in transit due to rough handling even though

the carton may not show external damage. When the damage is discovered upon unpacking, make a written request for inspection by the carrier's agent within fifteen days of the delivery date. Then file a claim with the carrier since such damage is the carrier's responsibility. By following these instructions carefully, we guarantee our full support of your claims to protect you against loss from concealed damage.

VISIBLE LOSS OR DAMAGE

Any external evidence of loss or damage must be noted on the freight bill or express receipt, and signed by the carrier's agent. Failure to adequately describe such external evidence of loss or damage may result in the carrier refusing to honor a damage claim. The form required to file such a claim will be supplied by the carrier.

DO NOT RETURN DAMAGED MERCHANDISE TO KEATING. FILE YOUR CLAIM AS STATED ABOVE.

PREPARING THE FILTER DRAWER

⚠ CAUTION

WATER IN ANY FORM AND HOT OIL DON'T MIX!

NOTE: Operator should be outfitted with proper protective attire: safety goggles, oil and heat resistant gloves, apron and footwear.

Filter Assembly inside of cabinet:

1. Pull the handle marked "Pull to Release Filter" (top of filter panel).
2. Remove the entire assembly from the cabinet by rolling it forward.
3. Pull the handle marked "Pull to Release Tub" (bottom of panel).
4. Slide the tub back, lift up and remove from cart.
5. Ensure all components are clean (**NOTE: Filter tub and components are dishwasher safe.**)
6. Install components into tub as follows (Figure 1):
 - 1st: Sump screen
 - 2nd: Filter paper
 - 3rd: Hold down ring (**NOTE 1**)
 - 4th: Acidox filter powder (**NOTE 2**)
 - 5th: Crumb basket

NOTE 1: Hold down ring makes a gasket-like seal on filter paper. Filter paper must be placed edge to edge from front to back, overlapping on sides. Filter Paper must be smooth and flat under hold down ring to get a proper seal. Lock the two tension arms into place by pushing down and rotating 90°.

NOTE 2: One package of Acidox is needed for every 40 lbs. of oil.

7. Place entire tub assembly onto the cart (**NOTE: Ensure the lip on the tub goes under the cart frame in the rear.**)

8. Reconnect the tub to the motor by pulling together the handles on the front of the tub and the handles on the side of the motor housing (Figure 2).

NOTE: Push on the front of the tub to verify connection. If tub moves, repeat steps 7-8.

9. Sprinkle Keating Acidox Powder evenly over the paper.

10. Replace crumb basket and push drawer fully into cabinet. Ensure the connection on top of the housing mates with the connection inside the cabinet.

Pull the front of the filter system lightly to verify proper connection.

NOTE: Cabinet door should be closed during filtration.

NOTE: For best results, new filter paper and Acidox Powder must be used for each fryer.

Figure 1

CRUMB BASKET

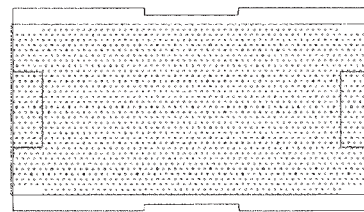

HOLD DOWN RING



FILTER PAPER

Sprinkle Acidox evenly on paper

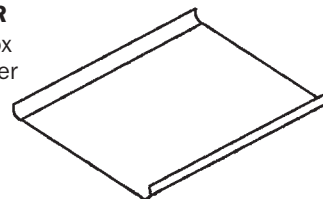

SUMP SCREEN

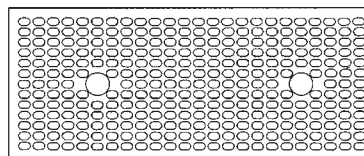

FILTER TUB

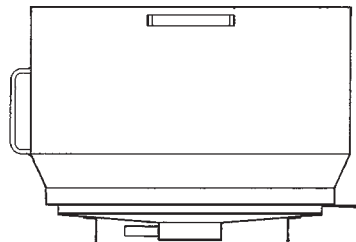
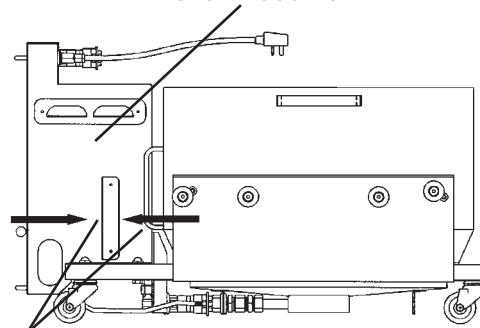

Figure 2

MOTOR HOUSING



Pull handles to connect tub to pump

PREPARING OIL FOR FILTRATION

NOTE: Oil in fryer must be between 250° - 350°F.

1. Turn fryer completely off.
2. Remove screen from over tubes/element with tongs or a Drain Clean Out Rod. Refer to Figure 3.

DRAIN CLEAN OUT ROD

Figure 3
Remove screen over elements/tubes

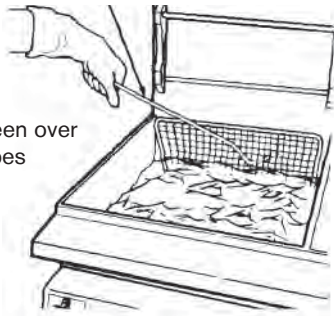

CAUTION

SCREEN OVER TUBES WILL BE VERY HOT AND SHOULD BE MOVED TO A SAFE PLACE.

3. Use spoon provided to stir oil. Bubbling will occur until all water is removed. Failure to do so will clog the filter paper. Refer to Figure 4.

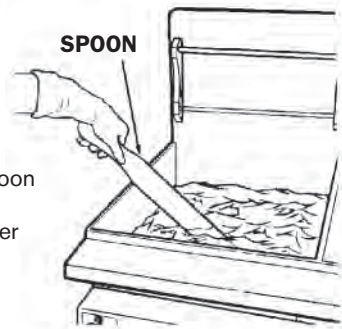

Figure 4
Stir with spoon provided to remove water

NOTE: Water settles in the cooler oil in the Cold Zone. If the water is not removed, the filter paper absorbs the water preventing the oil from passing through it.

FILTRATION

1. On filter assembly, have handle with the black knob set to "Oil to Fryer". Refer to Figure 5.
2. Open the drain valve slowly by lifting and then pulling the drain valve handle and drain fryer (handle with largest black knob).

NOTE: A Drain Clean Out Rod may be needed to loosen any solid residue. Use it only when valve is fully open.

3. Wipe crumbs from splashdeck while fryer is empty. Plug the filter unit into the outlet.

4. On the filter panel, turn the pump switch to the "ON" position. The green light will illuminate. Refer to Figure 5.

Figure 5
Front view of filter

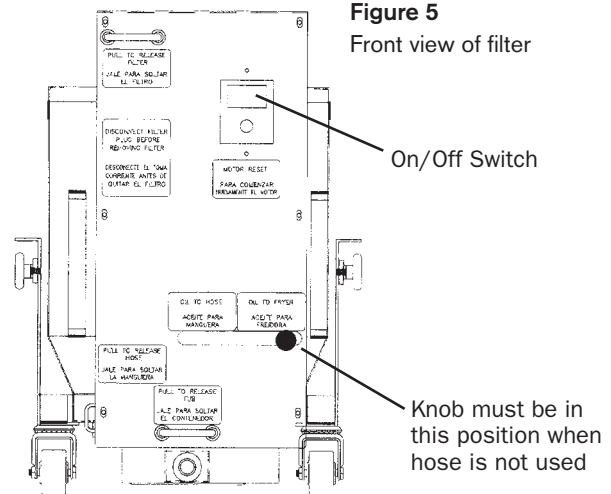

NOTE: If oil does not return to fryer, check the following:

- Filter tub setup (See Figure 1).
- Tub to motor connection (Figure 2).
- Water may have clogged the paper (Figure 4).
- Return valve for units with more than one fryer or separate filter cabinet is not opened.

5. Let the pump run with drain valve open to remove crumbs and residue from the bottom of fryer and the drain lines. Failure to do so may cause the drain lines to clog up.

NOTE: If the pump shuts down, turn it off and let the motor cool. Push the motor reset button located on the filter panel. Check filtering procedure or clean tub and paper if needed.

6. Let swirling action rinse down fryer.

7. Fully drain fryer.

NOTE: Pump should be run for at least 30 seconds after crumbs are removed from fryer. This will help prevent blockage in the drain lines.

8. Close drain valve by pushing in the large black knob and locking it into place and completely refill fryer. Refer to Figure 6.

Figure 6

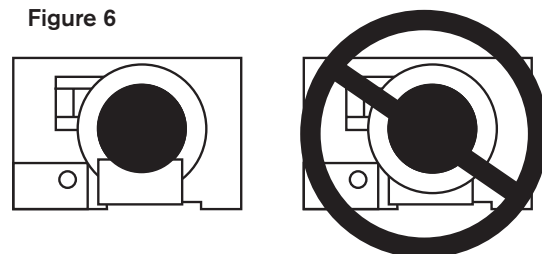

NOTE: The drain valve handle controls fryer's Main Power Switch. **If drain valve is not fully closed and locked, fryer will not operate.** See Figure 6.

9. Turn pump switch to the "OFF" position. Close return valve by pushing in the small black knob completely, after turning OFF the pump switch (for units with more than one fryer or central filter). See Figure 7.

Figure 7
Battery of 2 Fryers with Safe & Easy® Filter. **NOTE: Only 1 fryer can be filtered at a time.**

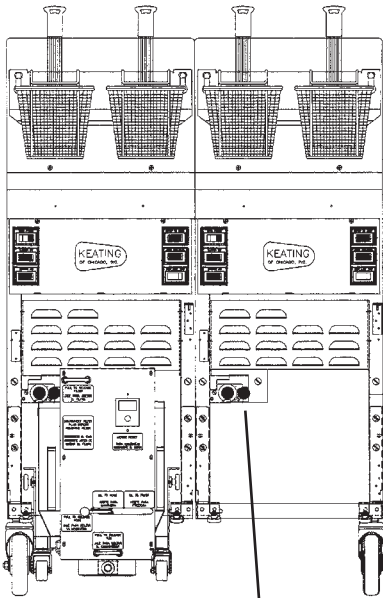

Return valve (small black knob) must be pulled to open when filtering and pushed closed when complete.

CLEAN UP

⚠ WARNING

FILTER UNIT AND PIPES WILL REMAIN HOT FOLLOWING FILTRATION. ALLOW THE UNIT TO COOL DOWN BEFORE CLEAN UP. FAILURE TO DO SO MAY RESULT IN SERIOUS INJURY TO THE OPERATOR.

1. Pull the handle marked "Pull to Release Filter" (top of filter panel).
2. Remove the entire assembly from the cabinet by rolling it forward.
3. Pull the handle marked "Pull to Release Tub" (bottom of panel).
4. Slide the tub back, lift up and remove from cart.
5. Remove crumb basket.

6. Push down on the 2 tension arms on the hold down ring, rotate 90°, and remove.

7. Remove the used filter paper and discard.

8. Remove sump screen.

9. Thoroughly clean the entire filter tub and all components.

NOTE: Tub and components are dishwasher safe.

10. Prepare drawer for next use (see PREPARING THE FILTER DRAWER section).

NOTE: Instructions for cleaning the fryer are in the Operating Section of the Fryer Manual.

DISCARDING THE OIL

NOTE: The hose provided with the filters should be used to discard the oil ONLY. DO NOT use the filter assembly to transport hot oil. DO NOT remove filter tub containing hot oil!

1. Prepare the filter drawer (see PREPARING THE FILTER DRAWER section).

NOTE: Acidox is not needed when discarding the oil.

2. Prepare the oil (see PREPARING OIL FOR FILTRATION section).

3. Connect the hose to the right side of the filter assembly in the front. See Figure 8.

Figure 8
Filter Side View

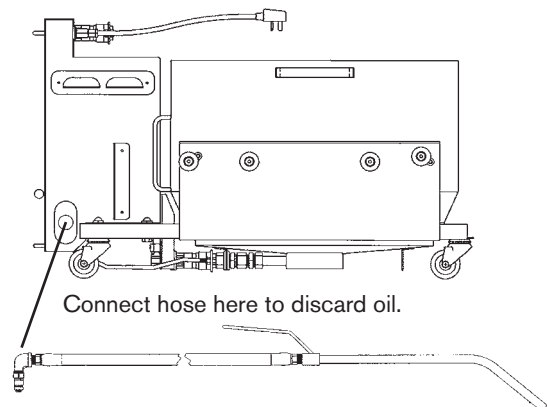

4. Push the small black knob on the filter panel to the left ("Oil to Hose").

5. Place the nozzle of the hose in an approved discard container.

6. Drain the oil.

7. Plug the filter into the receptacle.

8. Turn the motor switch ON (the green light will illuminate).

⚠ CAUTION

A KEATING FRYER OR FILTER SHOULD BE DRAINED ONLY UNDER THE SUPERVISION OF PROPERLY TRAINED PERSONNEL. WHEN DISCARDING OIL, A COVERED RECEPTACLE APPROVED FOR USE WITH HOT OIL SHOULD BE USED. USE OF A NON-APPROVED RECEPTACLE OR METHOD OF DRAINING THE OIL COULD JEOPARDIZE THE SAFETY OF THE OPERATOR.

NOTE: Keep the pump turned “ON” until bubbles occur in the discard receptacle. Allow the pump to run an additional 15 seconds to clear all pipes.

9. Turn the motor switch “OFF”.
10. Push the small black knob on the filter panel to the right (“Oil to Fryer”).
11. Close drain valve of the fryer (large black knob).
12. Hose can be removed by pulling the handle on the left of the motor housing.
13. Prepare filter tub for next usage (“PREPARING THE FILTER DRAWER”).
14. Clean excess oil from wand and quick disconnect on the hose.

⚠ CAUTION

To avoid damaging the fryer, do not power wash, spray or hose down unit while cleaning.

Pump must be primed with oil after boil-out with water.

Failure to lubricate pump may cause severe damage to Filter System and void the warranty.

QUICK HINTS**Do's**

1. Read and follow the filtering procedure.
2. Always verify 2 connections are engaged when filtering.
 - Quick disconnect under the tub to the motor housing.
 - Quick disconnect on top of the motor housing to the fryer or central filter quick disconnect.
3. Stir the oil completely before draining.
4. Place the sump screen under the filter paper.
5. Change the filter paper for each fryer filtered.

Don't's

1. Run water through the pump.
2. Filter oil without wearing the proper attire.
3. Filter cold oil (must be between 250°- 350°).
4. Use the hose to clean the fry tank (hose should only be used to discard the oil).
5. Powerwash, spray, or hose down the motor housing area, as electrical components are present.

⚠ CAUTION

HOT FLUID. DO NOT FILL BEYOND MAXIMUM FILL LINE LOCATED IN THE FRYER VESSEL.

■ SERVICE DIAGNOSIS

The following diagnosis is only to be used as a guide to qualified service personnel. Keating recommends that you use a qualified & licensed service company. (Equipment still under warranty requires it.)

NOTE: To correctly and quickly diagnose the system, the chart below should be followed in sequential order.

TROUBLE SHOOTING CHART

PROBLEM	PROBABLE CAUSE	SOLUTION
Motor runs but will not pump oil	<p>a. Tub not set up properly.</p> <p>b. Tub not connected to the motor housing properly.</p> <p>c. Filter not connected inside of cabinet.</p> <p>d. Valve not switched to "Oil to Fryer".</p> <p>e. If there's more than one fryer, return valve not open.</p>	<p>a. Place components in tub per the following:</p> <ol style="list-style-type: none"> 1. Sump screen on the very bottom. 2. Filter paper over sump screen (Lie it flat on the bottom, creasing the sides). 3. Hold down ring (ensure paper is not folded, lock hold down ring into place ensuring a tight seal). 4. Sprinkle Acidox powder evenly over filter paper (1 bag per 40 lbs. of oil). 5. Crumb basket for large debris. <p>b. Remove tub from filter cart:</p> <ol style="list-style-type: none"> 1. Pull the release handle located on the bottom of the filter control panel to remove tub from filter cart. 2. Place the tub onto the filter cart by first inserting the rear lip under the filter cart frame and then laying down the front of the tub flat onto the cart. 3. Connect the tub to the motor housing by pulling together the handles on the tub and the handles on the motor housing. (NOTE: verify tight connection by pushing back on the tub). <p>c. Ensure filter assembly is rolled straight onto the rails inside of the cabinet.</p> <ol style="list-style-type: none"> 1. Push filter assembly back as far as possible. 2. Ensure quick disconnect fitting on top of filter connects automatically with quick connect fitting inside of cabinet. 3. Pull on filter lightly to ensure a tight connection. <p>d. Set the black knob in the middle of the filter control panel to the far right. Try to filter again.</p> <p>e. Open the door of the fryer you wish to filter:</p> <ol style="list-style-type: none"> 1. Pull the return valve handle (small black knob) out as far as possible. 2. Attempt to filter again. When completed, push the black knob in as far as possible to close.

PROBLEM	PROBABLE CAUSE	SOLUTION
Motor runs but will not pump oil	a. Oil has not penetrated the filter paper	a. Let oil sit in the filter pan for approximately 2 minutes and try again.
Motor not making any noise	a. Not plugged in b. Motor has overheated	a. Plug filter into the receptacle inside of cabinet. Turn ON/OFF switch to "ON". b. Allow motor to cool for approximately 10 minutes. Press the reset button near the ON/OFF switch on the filter control panel and try again.
Oil not pumping through the hose	a. Valve not switched to "Oil to Hose".	a. Set the black knob in the middle of the filter control panel to the far left.

PREVENTATIVE MAINTENANCE

Preventative maintenance should be performed during & after each use of the filter. Following preventative maintenance procedures will help to keep your filter working efficiently. Proper care & servicing will lead to years of quality performance.

Familiarize yourself with the proper filtering procedure prior to attempting to filter:

1. To remove water, stir oil until bubbling stops; water will clog filter paper pores.
2. Verify all connections, especially quick disconnects (under tub and inside fryer or CF cabinet) are tight; not leaking oil or sucking air.
3. Use only one sheet of filter paper properly sealed under hold down ring.
4. Use a drain clean out rod if partial or full blockage in fryer drain is suspected.
5. If filter was used for fryer boil out, run oil through filter to lubricate motor/pump.
6. Clean filter and all components after each use. Do not permit oil to remain in filter drawer; it will clog the pump.
7. Verify all lights and controls operate.
8. Adhere to operating instructions in sequence given for proper filtration.
9. Prepare filter for next use by using new filter paper and Acidox Powder for each fryer.

CLEANING QUICK DISCONNECTS -

Cleaning Instructions Part Numbers 052572 & 060743 (Annual Cleaning is Recommended)

1. Remove disconnects from the filter unit.
2. Soak in a degreasing solution such as Keating Sea Powder (Part #000394).
3. While in degreasing solution, rotate the locking mechanism on Part #060743, breaking up any hardened grease inside the quick disconnect.

4. If there is a heavy build-up, you may need to soak the connectors overnight.

5. Rinse thoroughly before installing on filter.

WARRANTY REPAIRS

Keating's 1 year parts & labor warranty begins with the date of installation.

In the event that your filter, under warranty, needs repairs other than routine cleaning, you are requested to contact KEATING OF CHICAGO, INC. (1-800-KEATING) before calling a local service company.

■ SERVICE PARTS ORDERING

Parts may be ordered by part number by calling Keating at 1-800-KEATING or your service company. We recommend using genuine Keating Replacement Parts - engineered and manufactured specifically to meet exact specifications and requirements for Keating equipment.

Refer to the Keating Filter Limited Warranty for complete service and ordering information.

The model/serial plate is located on the back of the motor housing. The model and serial numbers are necessary when ordering.

WARNING AND OPERATING PLATES

All warning and operating plates on the Safe & Easy® Filter should be in place at all times. If plates are damaged or lost, replace them immediately.

■ PARTS LIST - SAFE & EASY® FILTER

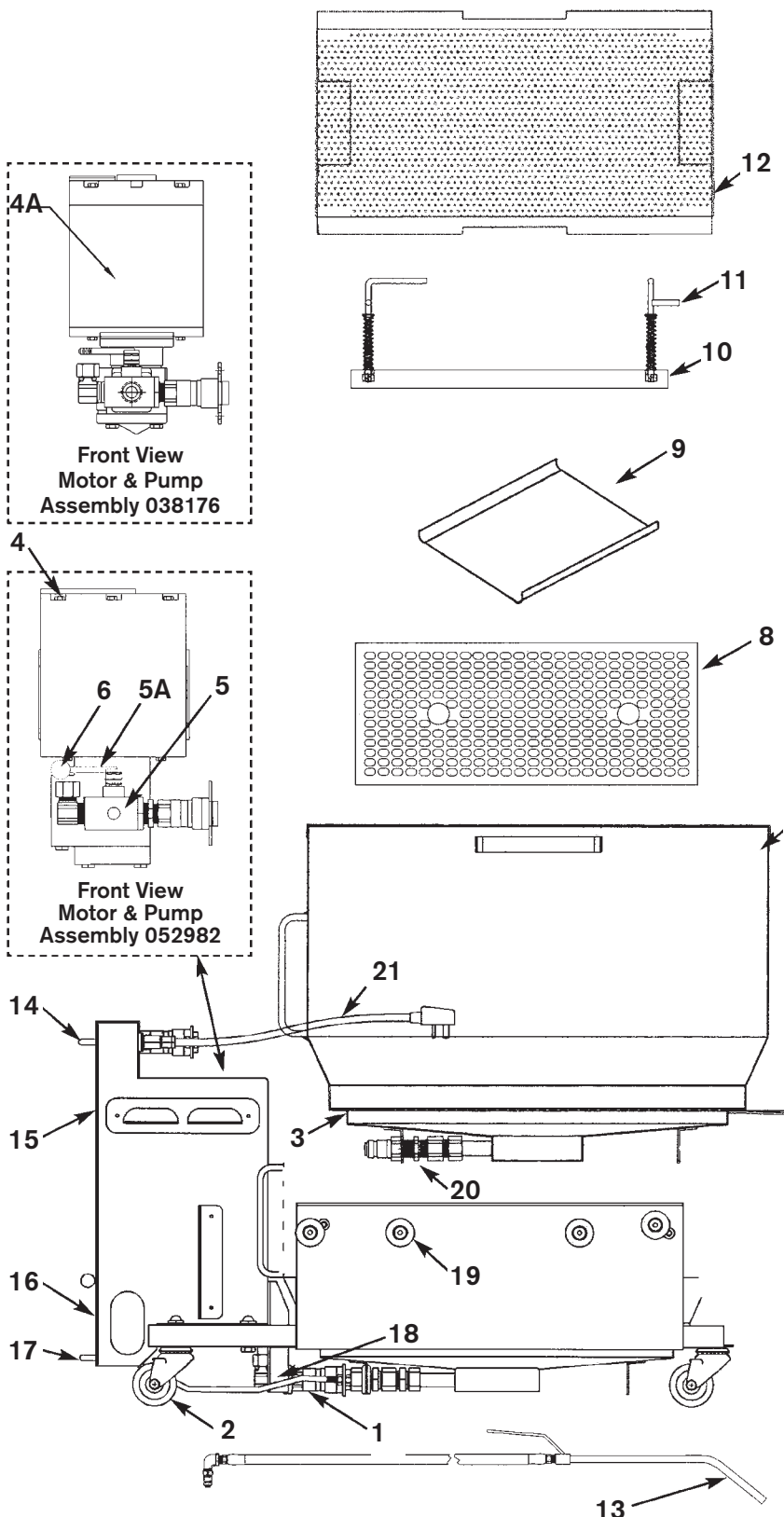

ITEM	DESCRIPTION	P/N
1	QUICK CONNECT COUPLER COMPRESSION FITTING STRAIGHT (FEMALE)	060743 011087
2	CASTER SWIVEL 2" 3/8-16 ACORN NUT 3/8 SPLIT LOCKWASHER	054919 011763 009085
3	QUICK CONNECT NIPPLE (MALE)	052572
4	MOTOR & PUMP	052982
4A	MOTOR & PUMP	038176
5	THREE WAY VALVE	030792
5A	VALVE HANDLE	053233
6	KNOB, BLACK	031532
7	FILTER TUB (ONLY)	
	14"	053444
	18"	053172
	20"	053123
	24"	054173
8	SUMP SCREEN	
	14"	059279
	18"	053195
	20"	053128
	24"	054331
9	FILTER PAPER SE	
	14"	058779
	18"	058780
	20"	058780
	24"	058781
10	HOLD DOWN RING	
	14"	052227
	18"	053200
	20"	053133
	24"	054315
11	HOLD DOWN RING HANDLE SPRING COLLAR	052817 006656 000512
12	CRUMB BASKET	
	14"	052662
	18"	053197
	20"	053130
	24"	054313
13	HOSE ASSEMBLY 6'	054031
14	QUICK CONNECT HANDLE	052647
15	ON/OFF SWITCH (not shown)	015119
16	QUICK CONNECT HANDLE TO HOSE (not shown) ACORN NUT	053438 015159
17	QUICK CONNECT HANDLE	052613
18	REPLACEMENT TUBING (call 1-800-KEATING)	
19	ROLLER	000520
20	FITTING 5/8 CC x 1/2 FPT FITTING 1/2 x 3/8 HEX	011837 013743
21	POWER CORD RECEPTACLE SPOON DRAIN CLEAN OUT ROD	055240 055227 029152 004622

■ WIRING DIAGRAM

FOR USE WITH MOTOR/PUMP PART # 052982 (REFER TO PARTS LIST)

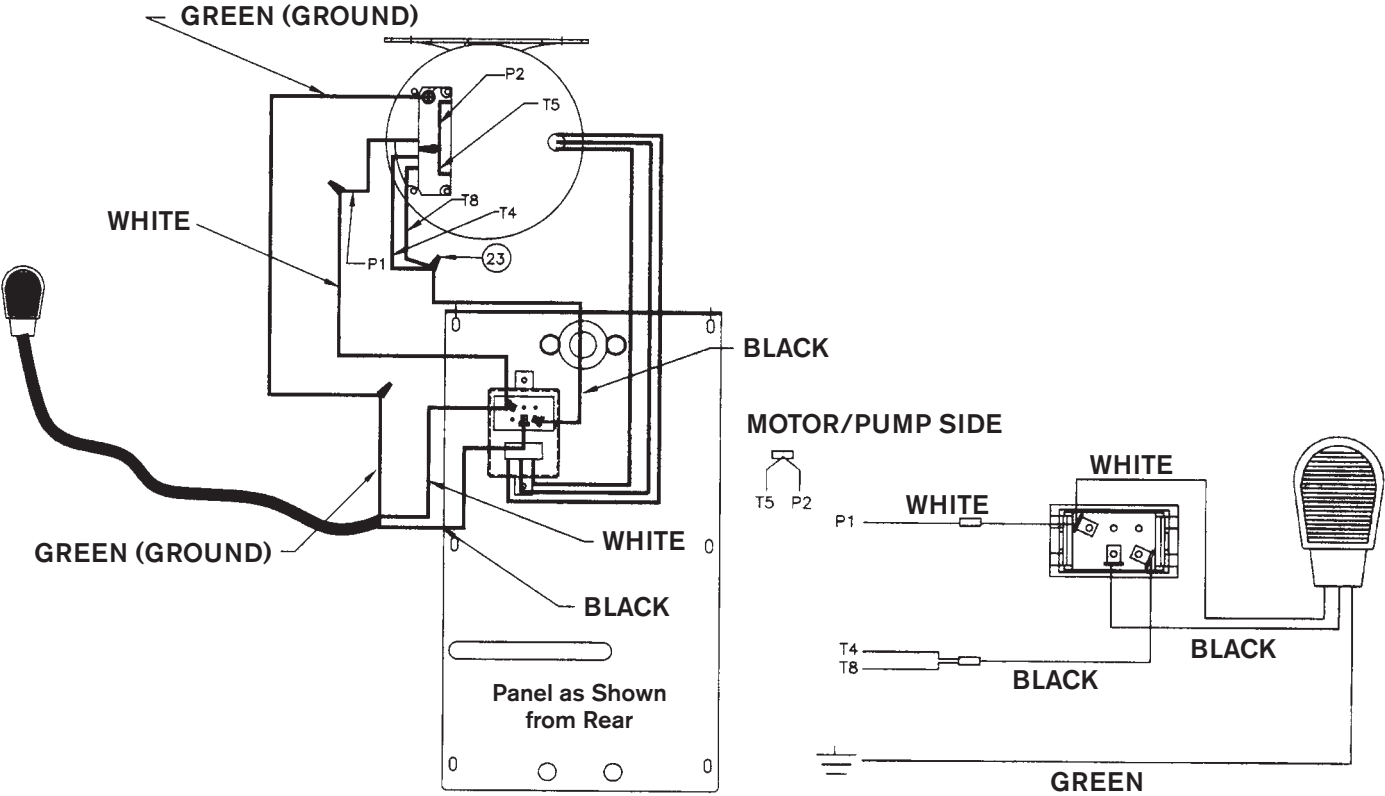

FOR USE WITH MOTOR/PUMP PART # 055173 (REFER TO PARTS LIST)

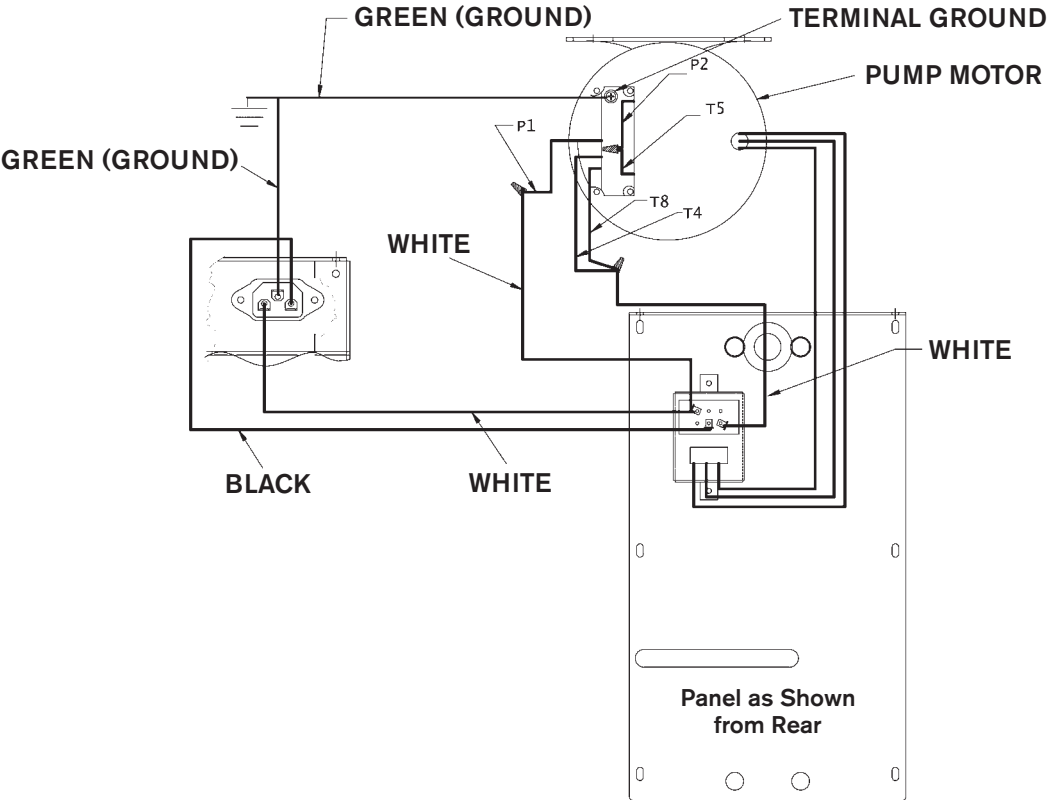



WARRANTY

LIMITED WARRANTY

Keating of Chicago, Inc. ("Keating") warrants to the original purchaser, ("Customer"), all new Keating Fryers, Filter Systems, Griddles, Keep Krisp[®], Custom Pasta Systems, Top-Side[™] Cookers, Computer Timers, Fryer & Pasta Vessels and Keating replacement parts ("products") installed after June 1, 1994 to be free of defects in material or workmanship, subject to the following terms and conditions.

LENGTH OF WARRANTY

All products other than Fryer & Pasta Vessels and replacement parts shall be warranted for a period of one year from the date of original equipment installation. Keating replacement parts are warranted for a period of ninety days from the date of installation. Fryer & Pasta Vessels are warranted as described below.

FRYER & PASTA VESSEL WARRANTY

Fryers purchased after June 1, 1994 carry a prorated vessel warranty on defects in materials or workmanship to the Customer based on the following scale:

Time from Installation Date	Fryer Vessel Warranty Credit
13-60 months	100%
61-72 months	80%
73-84 months	60%
85-96 months	40%
97-108 months	20%
109-120 months	10%

The credit for the defective fryer & pasta vessel shall be applied against the cost of the replacement vessel, utilizing Keating's then current price, upon return of the vessel to Keating only during the first 60 months, subject to the limitations described below.

LIMITATIONS OF LIABILITY

In the event of warranty claim or otherwise, the sole obligation of Keating shall be the repair and / or replacement at the option of Keating of the product or component part thereof. Such repair or replacement shall be at the expense of Keating except that the Customer shall pay the following expenses: all freight and labor expense for Keating replacement parts; for all other products, mileage exceeding 50 miles or travel more than one hour, labor costs of more than one person, overtime rates, truck charges, difference between ground and other mode of transportation, and holiday charges. Any repair or replacement under this Limited Warranty does not constitute an extension of the original warranty for any period for the product or for any component or part thereof. Parts to be replaced under this Limited Warranty will be repaired at the option of Keating with new or functionally operative parts. Keep Krisps and Computer Timers must be returned to Keating for warranty repair or replacement. Field repairs of those items are not authorized.

THE LIABILITY OF KEATING ON ANY CLAIM OF ANY KIND, INCLUDING CLAIMS BASED ON WARRANTY, EXPRESSED OR IMPLIED, CONTRACT, NEGLIGENCE, STRICT LIABILITY OR ANY OTHER THEORIES SHALL BE SOLELY AND EXCLUSIVELY THE REPAIR OR REPLACEMENT OF THE PRODUCT AS STATED HEREIN, AND SUCH LIABILITY SHALL NOT INCLUDE, AND CUSTOMER SPECIFICALLY RENOUNCES ANY RIGHTS TO RECOVER, SPECIAL, INCIDENTAL, CONSEQUENTIAL OR OTHER INJURIES TO PERSONS OR DAMAGE TO PROPERTY, LOSS OF PROFITS OR ANTICIPATED PROFITS, OR LOSS OF USE OF THE PRODUCT.

If any oral statements have been made regarding the Keating products, such statements do not constitute warranties and are not part of the contract sale. This Limited Warranty constitutes the complete, final and exclusive statement with regard to warranties.

THIS LIMITED WARRANTY IS EXCLUSIVE AND IS IN LIEU OF ALL OTHER WARRANTIES WHETHER WRITTEN, ORAL, STATUTORY OR IMPLIED, INCLUDING BUT NOT LIMITED TO ANY WARRANTY OF MERCHANTABILITY OR FITNESS FOR PARTICULAR PURPOSE OR WARRANTY AGAINST LATENT DEFECTS.

EXCLUSIONS

The warranties provided by Keating of Chicago, Inc. do not apply in the following instances:

1. Defects arising out of or resulting from improper installation or maintenance, abuse, misuse, modification or alteration by unauthorized service personnel, or any other condition not attributable to a defect in material or workmanship. Proper installation and maintenance are the responsibility of the installer and Customer, respectively. Proper installation and maintenance procedures are prescribed by the Keating Service Manual.
2. In the event that the product was damaged after leaving the factory due to flood, fire, other acts of God or accident, damaged during shipment should be reported to the carrier and is not the responsibility of Keating.
3. In the event the serial number or rating plate has been removed from the product or altered.
4. On parts which would normally be worn or replaced under normal conditions, including but not limited to electric bulbs, fuses, interior and exterior finishes, gaskets and radiants.
5. With regard to adjustments and calibrations such as leveling, tightening of fasteners or plumbing connections, improper gas pressure or improper electrical supply, the checking of and changes in adjustment and calibrations are the responsibility of the installer. Proper installation procedures are prescribed by the Keating Service Manual.
6. In the event of unauthorized repairs or alterations to the Keating product.
7. With the use of sodium chloride in pasta vessels or harsh chemicals in fryer or pasta vessels.
8. Installation in Household.

OTHER TERMS AND CONDITIONS

The Customer must provide proof of purchase from Keating.

This Limited Warranty is valid in the 50 United States, its territories, and Canada, and is void elsewhere. Keating products are sold for commercial use only. If any Keating product is sold as a component of another product or used as a consumer product, such Keating product is sold As Is without any warranty.

If any provision of this Limited Warranty is held to be unenforceable under the law of any jurisdiction, such provision shall be inapplicable in such jurisdiction, and the remainder of the warranty shall remain unaffected. Further in such event, the maximum exclusion or limitation allowable under applicable law shall be deemed substituted for the unenforceable provision.

This Limited Warranty shall be governed by and construed in accordance with the laws of the State of Illinois.

TO SECURE WARRANTY SERVICE

All repair services under this Limited Warranty must be authorized by Keating or performed at Keating. Authorization may be obtained by calling 1-800-KEATING within the Continental United States, Alaska, Hawaii, Puerto Rico and Canada during normal business hours (8 a.m. through 5 p.m. Central Time, Monday through Friday). When calling, please have the following information available: (1) name, address and telephone number of the Customer; (2) location of product, if different; (3) name, model number and serial number of the product; (4) installation date; and (5) description of defect. Keating will then issue a service authorization work order number to one of its approved independent servicing organizations, or request the product or part be shipped to Keating for repair or replacement, as appropriate. Any defective part subject to a claim under this Limited Warranty must be shipped freight prepaid to Keating for testing and examination. Keating's decision as to the cause and nature of any defect under this Limited Warranty shall be final.

■ **SERVICE INFORMATION:**

If you have a service related question call **1-800-KEATING**.
Please state the nature of the call; it will ensure speaking with the appropriate person.

Have your serial and model number available when ordering parts.

As continuous product improvement occurs, specifications may be changed without notice.

.....
KEATING LIMITED WARRANTY CARD

PLEASE COMPLETE AND MAIL AT ONCE--WARRANTY IS NOT IN EFFECT UNTIL CARD IS RETURNED, OR COMPLETE THE WARRANTY CARD ON OUR WEBSITE FOR YOUR CONVENIENCE.

COMPANY: _____

ADDRESS: _____

CITY: _____ STATE: _____ ZIP CODE: _____

DEALER NAME: _____

DATE OF PURCHASE: _____ INVOICE #: _____

SERIAL #: _____ MODEL: _____

FRYER GRIDDLE CUSTOM PASTA
 FILTER SYSTEM TOP-SIDE COOKER HOTPLATE

I HAVE READ THE INSTALLATION AND OPERATING INSTRUCTIONS.

SIGNED: _____ DATE: _____



KEATING OF CHICAGO, INC.
8901 West 50th Street
McCook, IL 60525-6001

1-800-KEATING
PHONE: 708-246-3000
FAX: 708-246-3100

Serving Those Who Serve the Very Best®