



**INSTANT RECOVERY®
ELECTRIC FRYER
SERIES 2006**

MANUAL

IMPORTANT:

THIS MANUAL PROVIDES SPECIFIC OPERATING INSTRUCTIONS FOR YOUR MODEL. USE THE INSTANT RECOVERY® ELECTRIC FRYER ONLY AS INSTRUCTED IN THIS MANUAL.

KEEP A COPY OF YOUR BILL OF SALE.

The date on the bill establishes the warranty period should service be required. If service is performed, it is in your interest to obtain and keep all receipts.

KEEP THIS MANUAL FOR TRAINING NEW PERSONNEL.

Record the Serial number and Model number of this Instant Recovery® Electric Fryer in the spaces provided. **Keep these numbers for future reference.**

SERIAL NUMBER

MODEL NUMBER

Keating commercial fryers are not intended for household use.

As continuous product improvement occurs, specifications may be changed without notice.

1-800-KEATING | keatingofchicago.com

NOTE:

PURCHASER SHOULD POST IN A PROMINENT LOCATION.

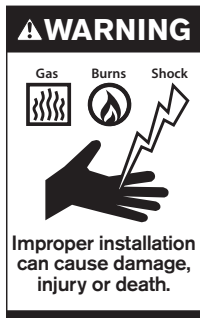

⚠ WARNING

Improper installation, adjustment, alteration, service or maintenance can cause property damage, injury or death. Read the installation, operating and maintenance instructions thoroughly before installing or servicing this equipment.



FOR YOUR SAFETY:

Do not store or use gasoline or other flammable vapors or liquids in the vicinity of this or any other appliance.

THE EQUIPMENT IS TO BE INSTALLED TO COMPLY WITH THE BASIC PLUMBING CODE OF THE BUILDING OFFICIALS AND CODE ADMINISTRATORS INTERNATIONAL, INC. (BOCA) AND THE FOOD SERVICE SANITATION MANUAL OF THE FOOD AND DRUG ADMINISTRATION (FDA).



■ TABLE OF CONTENTS

Important Safety Instructions	i	Oil Breakdown	8
INTRODUCTION	1	Limited Calibration	8 - 9
INSTALLATION		Thermostat Bulb Positioning.....	9
Damage During Shipment	1	SERVICE DIAGNOSIS	
Standard Features.....	2	Troubleshooting Chart.....	10 - 11
Safety Precautions	2	ORDERING PARTS	
Drop-In Fryer Counter Cut-Out/Installation	3	Service Parts Ordering	11
FIRST STEPS		Warning and Operating Plates	11
Positioning	3	PARTS LIST	12 - 20
Leveling	3	Electric Fryer Parts List & Assembly	12
Restraining Devices.....	4	BB Control Panel Parts List	13
Electrical Connection	4	TS Control Panel Parts List.....	14
OPERATING		CPU Control Panel Parts List	16 - 18
Filling	4	Basket-Lift Housing and Roller Guide Parts.....	19 - 20
Melting	5	WIRING DIAGRAMS	21 - 35
Cooking.....	5 - 6	Single Basket Lift Power Supply Box	21
Shutdown	6	BB Wiring Diagram	22 - 27
Draining.....	6	TS Wiring Diagram	27 - 34
Cleaning and Boil-Out	7	CPU Wiring Diagram	34 - 35
Electronic Timers	8	FRYER SPECIFICATIONS	
PREVENTATIVE MAINTENANCE		BB Models.....	36
Warranty Repairs.....	8	TS Models	37
Preventive Maintenance Chart	8	Warranty Information	38

■ INTRODUCTION

Instructions in this manual should be read thoroughly before attempting to operate this Keating Electric Fryer. All installation and service on Keating equipment must be performed by qualified, certified, licensed and/or authorized installation or service personnel.

Operating information for Keating equipment has been prepared for use by qualified and/or authorized personnel. Keating equipment is made in the USA and has American sizes of hardware. All metric conversions are approximate.

■ INSTALLATION INSTRUCTIONS

Proper installation will assure top performance. Alterations of any kind to your equipment will void the warranty. Before uncrating, check equipment carefully for damage.

IF EQUIPMENT ARRIVES DAMAGED

Keating does not assume responsibility for loss or damage incurred in transit.

IMPORTANT

This merchandise has been thoroughly inspected and carefully packed before leaving our plant. Responsibility for its safe delivery was assumed by the carrier at the time of shipment. Claims for loss or damage to the contents should, therefore, be made upon the carrier, as follows:

CONCEALED LOSS OR DAMAGE

Concealed loss or damage means loss or damage which does not become apparent until the mer-

chandise has been unpacked. The contents may be damaged in transit due to rough handling even though the carton may not show external damage. When the damage is discovered upon unpacking, make a written request for inspection by the carrier's agent within fifteen days of the delivery date. Then file a claim with the carrier since such damage is the carrier's responsibility. By following these instructions carefully, we guarantee our full support of your claims to protect you against loss from concealed damage.

VISIBLE LOSS OR DAMAGE

Any external evidence of loss or damage must be noted on the freight bill or express receipt, and signed by the carrier's agent. Failure to adequately describe such external evidence of loss or damage may result in the carrier refusing to honor a damage claim. The form required to file such a claim will be supplied by the carrier.

DO NOT RETURN DAMAGED MERCHANDISE TO KEATING. FILE YOUR CLAIM AS STATED ABOVE.

STANDARD FEATURES

- Highly polished stainless steel fryer vessel
- Highly polished stainless steel front
- Highly polished stainless steel elements
- Highly polished stainless steel thermostat bulb
- Highly polished stainless steel Hi-Limit sensor
- True Cold Zone for proper sedimentation
- Grid screen over elements
- Melt cycle
- 1" full port front drain valve on 10x11 and 14; 1-1/4" for 18 and larger
- High temperature limit control with manual reset
- Patented accurate temperature control system $\pm 7^{\circ}\text{F}$
- Ideal 35" working height
- One pair of split baskets or one full-size basket (18" model only)
- Circuit breaker protection for 208-240V 10x11 to 34x24 Models

STANDARD ACCESSORIES

- Keating Klenzer Sample
- Drain clean out rod

STANDARD FRYERS

- Sizes: 10x11 to 34x24
- Oil capacity 30 to 210 pounds
- NSF, ETL and ETLs listed

MODEL VARIATIONS

BB Model: BB Model Fryers feature Power On indicating light, a melt cycle and an electric stainless steel thermostat. The 14BB model can cook up to 72 lbs. of frozen fries or 75 lbs. of chicken per hour.

TS Model: TS Model Fryers have the highest input of all Keating fryers. The TS Model features a melt cycle, an electric stainless steel thermostat, two electronic timers and three indicating lights which display the status of the fryer's operation. The 14TS Model can cook up to 90 lbs. of frozen fries or 75 lbs. of chicken per hour.

TS Basket-Lift Model: TS Basket-Lift Model Fryers come with all the same features as the TS Model. The Basket-Lift mechanism lowers the baskets of food into the oil when the timer button is pressed and raises the baskets when the cooking cycle is complete. Split baskets are used for all models.

CM Model: BB and TS Counter Model Fryers are equipped with all of the same features as the BB and TS Models respectively, but take up less than three square feet of counter space. The 10x11CM Model can cook up to 36 lbs. of frozen fries per hour and the 14CM Model can cook up to 72 lbs. per hour.

CPU Model: CPU Model Fryers have the same input as the TS Models. The panel of switches and indicating lights are also the same. A programmable computer replaces the two timers and thermostat. A secondary thermostat, located in the fryer's cabinet, permits frying without the computer.

SAFETY PRECAUTIONS

⚠ WARNING

THIS SYMBOL WARNS YOU THAT SERIOUS BURNS OR OTHER INJURIES MAY RESULT IF SAFETY INSTRUCTIONS ARE NOT FOLLOWED.

- This service manual should be retained in a safe place for future reference. The installation of your new fryer must conform to current codes, with the current National Electrical Codes and regulations as applicable.
- Your ventilation hood, when installed, must conform to the current standards.
- You must maintain this appliance free and clear from combustibles.
- Adequate clearance for servicing and proper operation must be maintained. Your fryer is designed to be serviced from the front.
- Keating commercial fryers are not intended for household use.
- ALWAYS instruct new employees on proper fryer operation.
- ALWAYS turn fryer off each night.
- ALWAYS turn fryer off at customer power panel before servicing.
- NEVER leave a fryer unattended during operation.
- NEVER move a fryer when full of hot oil.
- NEVER introduce objects or liquids into fryer, while operational, which are not designed or made for cooking.
- THIS FRYER MAY NOT BE ALTERED, MODIFIED OR CHANGED IN ANY WAY.

**DROP-IN FRYER
COUNTER CUTOUT/INSTALLATION**

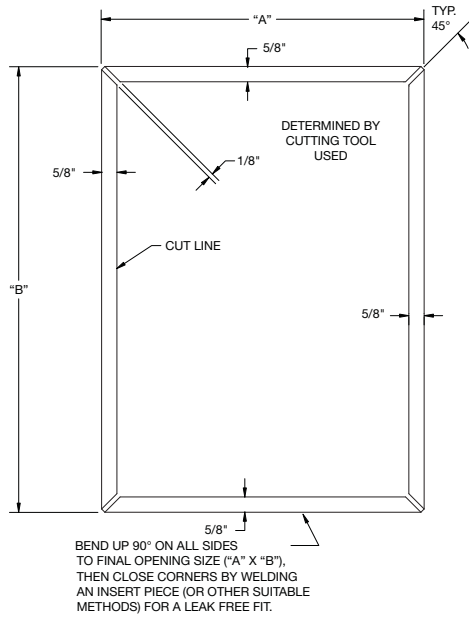

FRYER	"A"	"B"
10x11 DI ELECTRIC	13"	22"
14 DI ELECTRIC	16"	23 1/2"
18 DI ELECTRIC	20"	29"

INSTALLATION NOTES

1. All Drop-In Fryers must be 16" from any open flame.
2. Fryer must be located no more than 5" from counter top front.
3. Cabinet must be reinforced to support full weight of fryer in use (Fryer, oil, food, etc.).
4. Fryers must be properly ventilated and located under an exhaust hood.

**DROPPING THE FRYER
INTO THE COUNTER TOP**

It is only necessary to place the fryer in such a position that the front edge overlaps the front raised edge of the opening.

Push the fryer forward as far as it will go holding the fryer on approximately a 15° angle, and then drop the rear of the fryer into its proper position lowering it down gently so you do not deform the table or equipment stand.

FIRST STEPS

POSITIONING

The fryer must be placed under an exhaust hood with a fire retardant system. Your ventilation hood, when installed, must conform to the current standards. ALL connections and placement must comply with current local and national codes. It is the responsibility of the owner and local installer to comply with these regulations when installing the fryer.

Counter model and floor model fryers **must be restrained to prevent tipping** when installed in order to avoid splashing, spilling, etc. of hot liquid. The restraining method may be a manner of installation or by separate means.

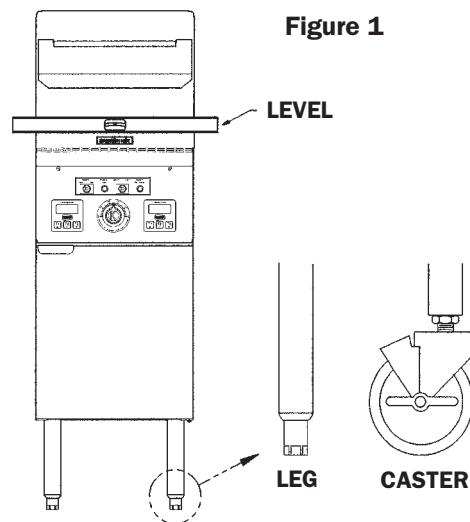

LEVELING

The fryer will operate at its highest efficiency when properly leveled. Place a level on fryer vessel from side to side. For fryers on legs, the bottom foot of the leg is adjustable. Looking from the bottom of the foot, turn clockwise to decrease height or counter clockwise to increase height until level. For fryers on casters, the casters are adjustable by loosening the jam nut and turning the caster in or out. When the desired level is reached, tighten the jam nut. Adjustments of more than 3/4" are not recommended on any caster. The same procedure should be followed to level the fryer from front to back.



RESTRAINING DEVICES

1. Adequate means must be provided to limit the movement of the appliance without depending on the connector and the quick-disconnect device or its associated piping to limit the appliance movement.

Fryer must also be restrained to prevent tipping when installed so that hot liquid splashing is avoided.

2. The restraint means must be attached to the rear of the Keating Electric Fryer within 2" of the center line width and approximately 1-5/8" from the bottom of the cabinet back to allow the restraining bolt to be anchored to the cabinet back between the cabinet bottom and inner liner.

If disconnection of the restraint is necessary, it must be reconnected when the Keating Electric Fryer is returned to its originally installed position.

ELECTRICAL CONNECTION

The Keating Instant Recovery® Electric fryer is equipped with a three wire terminal block for customer connections. The terminal block is located behind the fryer door on the right side behind a panel (held in place by two screws). Compare the fryer terminal connections to the appropriate wiring diagram for the fryer (see pages 21 thru 35) to see if the fryer is connected three phase or single phase. All wires/cords, plugs, receptacles and circuit breakers must be sized adequately for the full load rating of the fryer as specified by local codes, or in the absence of local codes, by the current National and Canadian Electrical Codes as applicable.

The Keating Electric Fryer is also equipped with a grounding lug next to the terminal block. For proper grounding procedures, see local codes or, in the absence of local codes, by the current National and Canadian Electrical Codes as applicable.

NOTE: A copy of your wiring diagram is shipped with your equipment.

NOTE: For fryers rated at 208-240 volts, the amperage ratings marked on the nameplates of the fryers are listed at 240 volts as required by ETL. If your fryer is to be fed by a 208 or 220 volt system, consult the Keating Fryer Specifications on pages 36 and 37 to determine the full load rating of the fryer.

NOTE: Fryers with Safe & Easy® Filters (Model BBSE or TSSE) or Central Filters will have separate 120 volt control circuit connections.

NOTE: A copy of your wiring diagram is located on the inside of the door.

NOTE: A hole has been punched in the rear of the fryer cabinet for a cord or conduit exit. If a cord is used, the National Electrical Code, ETL standards and most local codes require a bushing or strain relief (not provided by Keating) to protect the cord.

WIRE SIZE TABLE

Conductor Current (Amps up to)	Recommended Wire Size (AWG)
15	14*
20	12*
30	10*
40	8
55	6
70	4
95	2
125	0
145	2/0
165	2/0**
190	2/0**

*For runs greater than 75' up to 125', use the next wire size larger to keep the voltage drop to less than 3%. For runs greater than 125', consult the National Electrical Code Handbook to help determine the proper wire size.

**2/0 wire ambient temperature must be kept at less than 104°F (40°C).

OPERATING

FILLING

NOTE: Before filling the fryer make certain the fryer vessel is sanitized, dry and the drain valve is completely closed. Refer to figure 4 or 5 on page 6 for location of drain valve.

WARNING

BE SURE THE HEATING ELEMENTS ARE COMPLETELY COVERED WITH OIL BEFORE SWITCHING THE FRYER ON. IF OIL LEVEL DROPS BELOW TOP OF HEATING ELEMENTS, SEVERE DAMAGE TO FRYER AND INJURY TO OPERATOR MAY RESULT.

CAUTION

WATER IN ANY FORM AND HOT OIL DON'T MIX!

CAUTION

OIL EXPANDS WHEN HEATED. THE MAX LEVEL LINE HAS BEEN PROVIDED TO ENSURE OPTIMUM COOKING WHILE ENSURING THE SAFETY OF THE OPERATOR. DO NOT OVERFILL THE FRYER VESSEL.

Figure 2
Fill Level Line

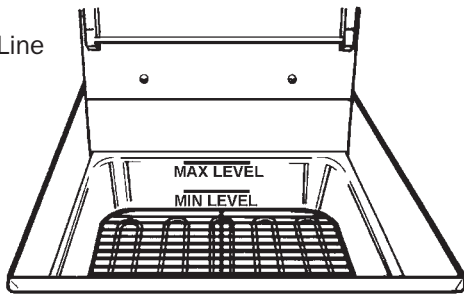

BB & TS, CPU and Basket-Lift Models

1. Fill the fryer vessel with oil up to the “Max Level” line.
2. If using solid shortening, remove screen and firmly pack solid shortening between the heating elements. Proceed to Melting section for instructions on use of the melt cycle.

MELTING

The Keating Melt Cycle safely melts solid shortening in the fryer vessel without scorching.

⚠ WARNING

BEFORE APPLYING POWER TO THE FRYER, MAKE SURE THE ELECTRIC CONNECTIONS ARE SECURE AND THE FRYER HAS BEEN PROPERLY FILLED WITH OIL.

A. BB, TS and Basket-Lift Models

1. Set the thermostat to the desired temperature.
2. If using solid shortening, set Melt-Fry switch to the “MELT” position. Stay in the “MELT” cycle until the shortening has melted completely and is at the “Max Level” line before switching to the “FRY” position for cooking.

B. CPU Models

*See separate computer instructions or call 1-800-KEATING.

NOTE: During the “MELT” cycle, the elements are on for approximately 5-7 seconds and off for approximately 50 seconds.

COOKING

Keating Instant Recovery® Electric Fryers are designed to provide maximum production efficiency and deliver high quality food products. Low-temperature cooking, highly polished stainless steel and a true COLD ZONE mean extended oil life. Follow cooking procedures for your model.

⚠ WARNING

OPERATION OF THIS FRYER SHOULD BE LIMITED TO PERSONNEL WHO HAVE BEEN THOROUGHLY TRAINED IN OPERATING PROCEDURES.

USE ONLY KEATING APPROVED BASKETS IN YOUR FRYER. NEVER OVERFILL FRY BASKETS. DO NOT BANG BASKETS ON BASKET HANGERS OR FRYER VESSEL.

CARE SHOULD BE TAKEN WHEN LOWERING BASKETS INTO FRYER TO PREVENT SPLASHING HOT OIL FROM FRYER VESSEL.

NEVER LIFT BASKETS DIRECTLY OUT OF THE FRYER VESSEL WITHOUT DRAINING AS SEVERE INJURY MAY RESULT.

NOTE: For safety purposes, all Hi-Limit controls are manually reset. Always check the Hi-Limit reset button before attempting to use the fryer. If the Hi-Limit has tripped, the fryer will not operate.

NOTE: For a fryer with a Central or Safe & Easy® Filter, always check the rear drain operating handle before attempting to use the fryer. A safety switch prevents the fryer from operating if the handle is not pushed in completely and locked into place.

A. BB Models

1. Fill fryer as described on page 4-5 - FILLING.
2. Set Power switch to the “On” position. “POWER ON” light will be illuminated.
3. Set the Melt-Fry switch to “FRY.”
4. Set thermostat to the desired frying temperature (between 325°F and 335°F).
5. When the oil reaches the desired frying temperature, lower filled basket(s) slowly into the hot oil.
6. When cooking cycle is complete, carefully lift basket(s) out of oil. Place them on basket hanger (on splashback of fryer) to allow draining of excess oil.

B. TS Model

1. Fill fryer as described on pages 4-5 - FILLING.
2. Set Power switch to the “On” position. “POWER ON” light will be illuminated.
3. Set the Melt-Fry switch to “FRY.”
4. Set thermostat to the desired frying temperature (between 325°F and 335°F).
5. When the oil reaches the desired frying temperature, the “READY TO COOK” light will illuminate.
6. Lower filled basket(s) slowly into the hot oil.
7. Set timer for left or right side basket, whichever is being lowered into oil. For programming instructions, see page 8.

8. When timer sounds, lift basket out of oil. Place on basket hanger (on splashback of fryer) to allow draining of excess oil.

C. Basket-Lift Models

1. Fill fryer as described on page 4 - FILLING.
2. Set Power switch to the "On" position. "POWER ON" light will be illuminated.
3. Set the Melt-Fry switch to "FRY."
4. Set thermostat to the desired frying temperature (between 325°F and 335°F).
5. When the oil reaches the desired frying temperature, the "READY TO COOK" light will illuminate.
6. Fill basket(s) to proper level and place on upper bar of lift rod(s).
7. Set timer(s) to desired cooking time. For programming timers see page 8.
8. Push "T1," "T2" or "T3" buttons on timer(s). Basket(s) will automatically lower into fryer vessel.
9. When cooking cycle is complete, an audible alarm will sound and the basket(s) will raise automatically. Allow oil to drain before removing baskets.

D. CPU Model

*See separate computer instructions or call 1-800-KEATING.

SHUTDOWN

A. BB, TS and Basket-Lift Models

1. Turn fryer Power switch to "OFF" position.

B. CPU Model

1. Set Main Power On/Off switch to the "OFF" position.

DRAINING

⚠ WARNING

ALWAYS SHUT THE FRYER OFF COMPLETELY BEFORE DRAINING. THE FRYER SHOULD BE DRAINED ONLY UNDER THE SUPERVISION OF PROPERLY TRAINED PERSONNEL. A DRAIN PIPE AND COVERED CONTAINER SUITABLE FOR USE WITH HOT OIL SHOULD BE USED TO ENSURE THE SAFETY OF THE OPERATOR.

1. Operator should be outfitted with proper attire including:
 - Oil and heat resistant gloves
 - Oil and heat resistant apron
 - Safety goggles
 - Oil and heat resistant footwear

Figure 3
Operator in Safety Gear

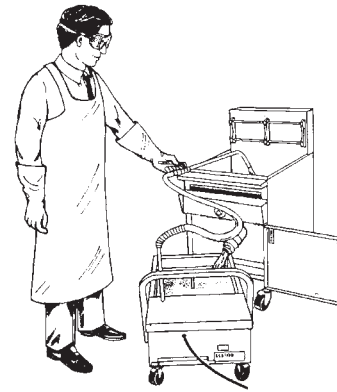

2. Turn off the fryer and open the door.
3. For front drain fryers, put approved container under drain valve. For fryers with a central filter, slide filter drawer in completely.
4. For front drain fryers, slowly turn handle forward to avoid splashing. The drain valve will be completely open after 1/4 turn.
5. For units with rear drain valves, slowly pull drain valve operating handle straight out (unhook from metal latch first). See Safe & Easy operator's manual for instructions on how to filter.

Figure 4
Front Drain Valve

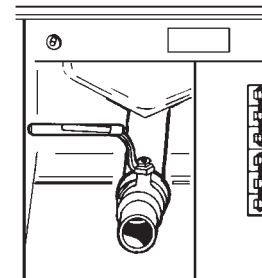
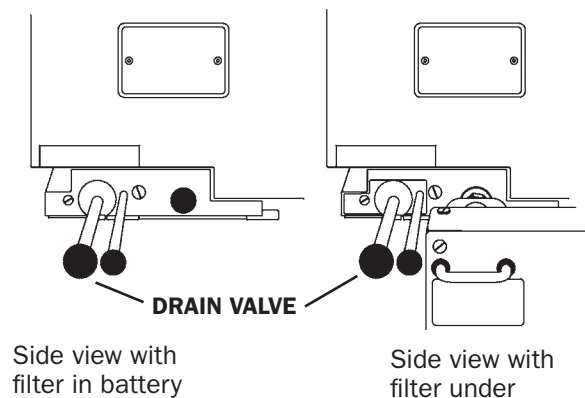

Figure 5
Safe & Easy® Filter



⚠ WARNING

UNDER NO CIRCUMSTANCES SHOULD YOU PERMIT HOT OIL TO COME IN CONTACT WITH WATER OR ICE. ALL DRAINING SHOULD BE DONE UNDER THE SUPERVISION OF PROPERLY TRAINED PERSONNEL. A DRAIN PIPE AND COVERED CONTAINER SUITABLE FOR USE WITH HOT OIL SHOULD BE USED WHENEVER A FRYER IS DRAINED. ALWAYS DRAIN OIL INTO A COVERED RECEPTACLE APPROVED FOR THE TRANSPORTATION OF HOT OIL.

CLEANING AND BOIL OUT

When cleaning and boiling out your fryer use Keating Sea Powder and Keating Klenzer to keep your fryer in top condition. Keating Sea Powder dissolves any grease build up - even carbonized grease in fryer vessels - one of the leading causes of premature oil breakdown. And once your fryer vessel is clean, use Keating Klenzer, the finest dry stainless steel polish available, to restore your Keating Instant Recovery® Electric fryers' exterior to its original luster.

⚠ CAUTION

To avoid damaging the fryer, do not power wash, spray or hose down unit while cleaning.

Figure 6
Keating Klenzer
and Sea Powder



1. Put on safety attire. See page 6 - DRAINING.
2. Turn the fryer off.
3. Drain oil from fryer, see page 6. Filtering may be done at this step.
4. Remove oil container to a secure area to prevent accidental spillage.
5. Fill fryer vessel to "Max Level" line with water.

⚠ WARNING

UNDER NO CIRCUMSTANCES SHOULD THE FRYER BE LEFT UNATTENDED DURING BOIL-OUT. TRAINED PERSONNEL MUST BE PRESENT DURING THE PROCEDURE TO PREVENT BOIL OVER OR TO TURN OFF THE POWER IF WATER DROPS BELOW HEATING ELEMENTS.

6. Set thermostat and turn fryer on to bring water to a gentle boil.
7. Once boil has been reached, turn fryer off.

8. Dissolve 2/3 cup of Keating Sea Powder for every five gallons of water and let soak for 1/2 hour. If there is a large build-up of carbonized grease, allow fryer to soak overnight.

⚠ CAUTION

DO NOT DAMAGE OR REMOVE THERMOSTAT BULB AS THIS MAY AFFECT THE ACCURACY OF THE FRYER.

9. While soaking, a natural fiber brush may be used to scrub the inside walls of fryer.
10. Drain the water and Sea Powder into a dry, suitable receptacle and remove from cooking area.
11. Spread Keating Klenzer liberally on sides of fryer vessel.
12. At this point, a non-abrasive scouring pad may be used to remove the now softened carbonized grease.
13. Thoroughly rinse fryer vessel with potable water to remove all Klenzer.
14. Prior to refilling with oil, wipe the inside of the fryer vessel making sure all water and Klenzer has been removed.

⚠ CAUTION

WATER IN ANY FORM AND HOT OIL DON'T MIX!

15. Close drain valve.

⚠ WARNING

FAILURE TO CLOSE DRAIN VALVE BEFORE REFILLING THE FRYER MAY RESULT IN SERIOUS INJURY.

⚠ WARNING

WHEN YOUR FRYER IS BEING USED IN CONJUNCTION WITH A CENTRAL FILTER, DISCONNECT POWER SUPPLY BEFORE RESETTING MOTOR TO PREVENT SERIOUS INJURY WHEN RESET SWITCH IS ENGAGED (SEE FILTER MANUAL).

16. Check thermostat bulb positioning - see page 9.
17. Refill the fryer with new or filtered oil.

NOTE: MSDS Sheets for Keating Klenzer, Sea Powder & Acidox are available on-line at www.keatingofchicago.com.

ELECTRONIC CONTROL TIMERS

The electronic timers provide a clearly visible and accurate display and are very easy to use.

Figure 7
Electric Timer

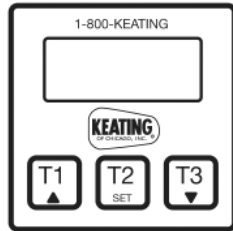

PROGRAMMING

To program the timers, the unit must be in the idle mode. Press and hold the set button for approximately two seconds. The display will show "SEt". Press T1, T2, or T3 for the cook time to be programmed. The display will show the current setting for that cook time. Use the up or down button to increment or decrement the setting. When the setting is correct, press and hold the set button again for approximately two seconds. The display will show "StO" for approximately two seconds and the timer will return to normal operation. Repeat the process as necessary for the other timers.

OPERATING LOGIC

When the timer is powered up, the display will show the time setting for the cook time that was operated last and the relay output contacts will be open. To start a cycle, press the desired cook time button (T1, T2, T3). The display will begin to countdown from the preset time setting and the relay output contacts will close. During the countdown the colon will flash at a one-second rate. When the countdown has reached "00:00" the relay output contacts will open, the display will flash, and the audible alarm will sound. To cancel the audible alarm, press any button.

PAUSE FEATURE

To pause a cycle in progress, press any button. The relay output contacts will open, the display will flash, and the countdown will pause. To resume the countdown, press any button. The display will resume the normal countdown and the relay output contacts will close.

CANCELING A CYCLE

To cancel a cycle in progress press and hold any button for approximately two seconds. The relay output contacts will open and the display will show the time setting for the cook time last used.

■ MAINTENANCE

WARRANTY REPAIRS

Keating's warranty begins with the date of installation. In the event that your Instant Recovery® Fryer, under warranty, needs repairs other than routine maintenance or cleaning, you are required to contact Keating of Chicago (at 1-800-KEATING) before calling a local service company.

PREVENTIVE MAINTENANCE

Preventive maintenance should be done in daily, weekly, monthly and yearly intervals as necessary. Following preventive maintenance procedures will help keep your fryer working efficiently. Proper care and servicing will lead to years of quality performance.

TIME FRAME	OPERATOR/OWNER
AT LEAST DAILY*	<ul style="list-style-type: none"> • Check that the oil is up to "Max Level" line. • Clean all baskets. • Drain, strain or filter oil.
AT LEAST WEEKLY*	<ul style="list-style-type: none"> • Drain and clean fryer. • Boil-out fryer.
AT LEAST MONTHLY*	<ul style="list-style-type: none"> • Check lights and controls. • Verify Thermostat settings. • Test Hi-Limit control. • Verify wire connections.
TIME FRAME	QUALIFIED SERVICE PERSONNEL
AT LEAST YEARLY*	<ul style="list-style-type: none"> • Calibrate thermostat.

*High production facilities should be checked more often. Contact the factory or a local service company to perform maintenance and repairs.

Oil Breakdown

As part of a "Preventive Maintenance Program", the oil in your fryer needs to be filtered regularly to avoid breakdown. The initial investment in the frying system is less than the total overall costs of oil during the life of the fryer, and with regular filtering, you can realize substantial savings in oil costs as well as maintenance charges.

LIMITED CALIBRATION

(Less than 15° difference)

Thermostat knob removed to reveal calibration screws

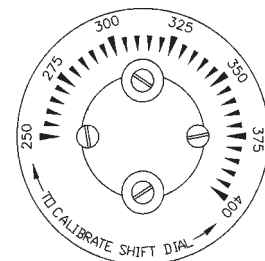

You will need: One standard flat blade screwdriver
One accurate fryer thermometer

1. Set thermostat to desired frying temperature.
2. Allow thermostat to cycle three times.
2. Allow fryer to cycle three times.
3. Place an accurate thermometer in the oil.
4. If temperature of fryer is found to be more or less than 15°F off, remove the thermostat knob. There are (4) screws holding the dial plate in place. Loosen the screws and reset the dial plate to match the thermometer reading.

⚠WARNING

DO NOT ADJUST THE THERMOSTAT SET SCREW - IT VOIDS ANY WARRANTY ON PART.

NOTE: Locate thermometer in same position for every calibration. Position next to upper heating element is recommended.

Thermostat Bulb Positioning

Keating's patented thermostat application is accurate within $\pm 7^{\circ}\text{F}$ of the dial setting between 250°F and 350°F. This accuracy is attained only if the thermostat bulb is placed properly against the top element using element clamps. If the bulb is too far away from the element, the fryer will overshoot.

Overshoot: The thermostat takes a long time to cycle and then misses its preset temperature by 20°F - 40°F yielding a poor quality product.

■ SERVICE DIAGNOSIS

The following diagnosis is only to be used as a guide to qualified service personnel. Keating recommends that you use a qualified & licensed service company. (Equipment still under warranty requires it.) Call 1-800-KEATING if you need assistance in locating a qualified service company.

A properly adjusted Keating Instant Recovery® Electric Fryer, with no load, will cycle “on” approximately every 2 1/2 to 3 minutes. Each cycle will last 15-25 seconds, ensuring that the temperature setting is held within a narrow band.

NOTE: To correctly and quickly diagnose the system, the chart below should be followed in sequential order.

TROUBLE SHOOTING CHART

PROBLEM	PROBABLE CAUSE	SOLUTION
Fryer won't heat	<ul style="list-style-type: none"> a. No electricity to fryer (“POWER ON” switch is off). b. No electricity to control circuit (models with Basket-Lift or Central Filter). c. Fryer circuit breakers have tripped. d. Hi-Limit has been activated. e. Rear drain valve handle has not been fully closed (fryers with filter only). f. ON/OFF is faulty. g. MELT/FRY switch is faulty. h. Contactor is faulty. i. Thermostat is faulty. 	<ul style="list-style-type: none"> a. Connect fryer to an approved source of power. b. Connect 120V terminal block to an approved source of power. c. Reset circuit breakers. d. Push in Hi-Limit Reset button located behind fryer door. Check calibration of thermostat and operation of Hi-Limit and contactor. e. Fully close and latch rear drain valve handle. Turn fryer OFF and then ON to restart. f. Replace ON/OFF switch. g. Replace MELT/FRY switch. h. Replace contactor. i. Replace thermostat.
Fryer has poor recovery or runs cold	<ul style="list-style-type: none"> a. Over-filling baskets. b. Fryer vessel overfilled with oil. c. Thermostat out of calibration. d. Carbon coating on elements. e. Element is faulty. f. Thermostat is faulty. g. Contactor is faulty. h. Low incoming voltage. 	<ul style="list-style-type: none"> a. Don't overfill baskets. b. Fill fryer up to “Max Level” line as oil expands when heated. c. Calibrate thermostat. (See Calibration). d. Boil-out fryer. (See Cleaning and Boil-Out). e. Replace Element. f. Replace thermostat. g. Replace contactor. h. Verify proper incoming voltage.
Fryer is overheating	<ul style="list-style-type: none"> a. Thermostat bulb improperly placed. b. Thermostat out of calibration. 	<ul style="list-style-type: none"> a. Adjust bulb position. (See Thermostat Bulb Positioning). b. Calibrate thermostat (See Calibration).

PROBLEM	PROBABLE CAUSE	SOLUTION
Oil in fryer vessel smokes	<ul style="list-style-type: none"> a. Oil has begun to break down. b. High carbon content in oil. c. Dirty fryer vessel. d. Inferior grade of oil. e. Fryer is overheating. 	<ul style="list-style-type: none"> a. Replace oil. b. Filter oil completely, replace if necessary. c. Boil-out fryer. See Cleaning and Boil-Out. d. Check with oil supplier for higher grade of oil needed for your cooking applications. e. Check calibration of thermostat (See Calibration) and replace if necessary. Check if Hi-Limit trips at 425°F. If not, replace Hi-Limit.
Oil in fryer vessel boils over	<ul style="list-style-type: none"> a. Baskets are overfilled. b. Fryer vessel overfilled with oil. c. Oil is breaking down and foaming. d. Water in cold zone. 	<ul style="list-style-type: none"> a. Don't overfill baskets. b. Fill fryer up to "Max Level" line as oil expands when heated. c. Replace oil. d. Stir oil with a paddle until water boils off. Filter oil. If water remains, let oil cool and drain a quart of it.
Contactors chatters	<ul style="list-style-type: none"> a. Voltage is low to fryer. b. Contactor coil faulty. c. Connections are loose. d. Thermostat contacts do not close properly. 	<ul style="list-style-type: none"> a. Contact your electrician or the local power company and have the incoming power checked. b. Replace contactor. c. Tighten connections. d. Replace thermostat.
TS MODELS		
Basket-Lift mechanism will not operate	<ul style="list-style-type: none"> a. Connections are loose or timer is faulty. b. Actuator is faulty. c. Control circuit breaker has tripped. d. Relay is faulty. 	<ul style="list-style-type: none"> a. Tighten connections. Replace timer if it will not operate. b. Replace actuator. c. Reset circuit breaker. d. Replace relay.

■ ORDERING PARTS

Parts may be ordered by calling 1-800-KEATING or your local Keating service company. We recommend using genuine Keating Replacement Parts - engineered and manufactured specifically to meet exact specifications and requirements for Keating equipment.

Refer to the Keating Electric Fryer Limited Warranty for complete service and ordering information.

The model/serial plate is attached to the inside of the front door. The serial and model numbers are necessary when ordering.

WARNING AND OPERATING PLATES

All warning and operating plates on the Instant Recovery® Electric Fryer should be in place at all times. If plates are damaged or lost, replace them immediately.

■ PARTS LIST - ELECTRIC FRYER

ITEM	DESCRIPTION	MODEL	P/N 220V ELEMENT	P/N 440V ELEMENT	10x11	Quantity Per Model				
						14	18	20	24	34x24
1	HEATING ELEMENT									
	2500 W	BB	004347		3					
		BB		006342	3					
	3800 W	TS	005623	004348	3					
	4350 W	BB	004349	004350		3				
	6000 W	BB	004353	004352			3	3		
		TS	004353	004352			4	4		
		BB	004355	022287					4	5
		TS	004355	022287					5	6
	6500 W	TS	014493	019256		3				
	TEFLON RING	BB, TS	004318	004318						2 Per Element
	5/8" FLAT WASHER	BB, TS	004319	004319						2 Per Element
	5/8" - 16 BRASS LOCKNUT	BB, TS	004323	004323						2 Per Element
	LCKWSHR, INT #10 H-TEMP	BB, TS	011562	011562						2 Per Element
RING TERM #10 HI-TEMP	BB, TS	011881	011881						2 Per Element	
FLAT WASHER #10 HI-TEMP	BB, TS	059502	059502						2 Per Element	
NUT 10-32	BB, TS	000361	000361						2 Per Element	

ITEM	DESCRIPTION	MODEL	P/N	10x11	Quantity Per Model				
					14	18	20	24	34x24
2	ELEMENT CLAMP	ALL	004167	2	2	2	2	2	2
3	ELEMENT SPACER	ALL	004145			4	4		
4	FRYER VESSEL		CALL 1-800-KEATING	1	1	1	1	1	1
5	DRAIN VALVE, FRONT 1"	BB, TS	004553	1	1				
	DRAIN VALVE, REAR 1"	BB, TS	016341	1	1				
	DRAIN VALVE, FRONT 1 1/4"	BB, TS	004554			1	1	1	2
	DRAIN VALVE, REAR 1 1/4"	BB, TS	016342			1	1	1	2
	DRAIN VALVE, FRONT 2"	OPTIONAL	019722			1	1	1	2
6	BASKET HANGER		SEE BELOW		1	1	1	1	

ITEM	DESCRIPTION	10x11	14	18	20	24
6	BASKET HANGER	018553	018477	018556	018559	018562

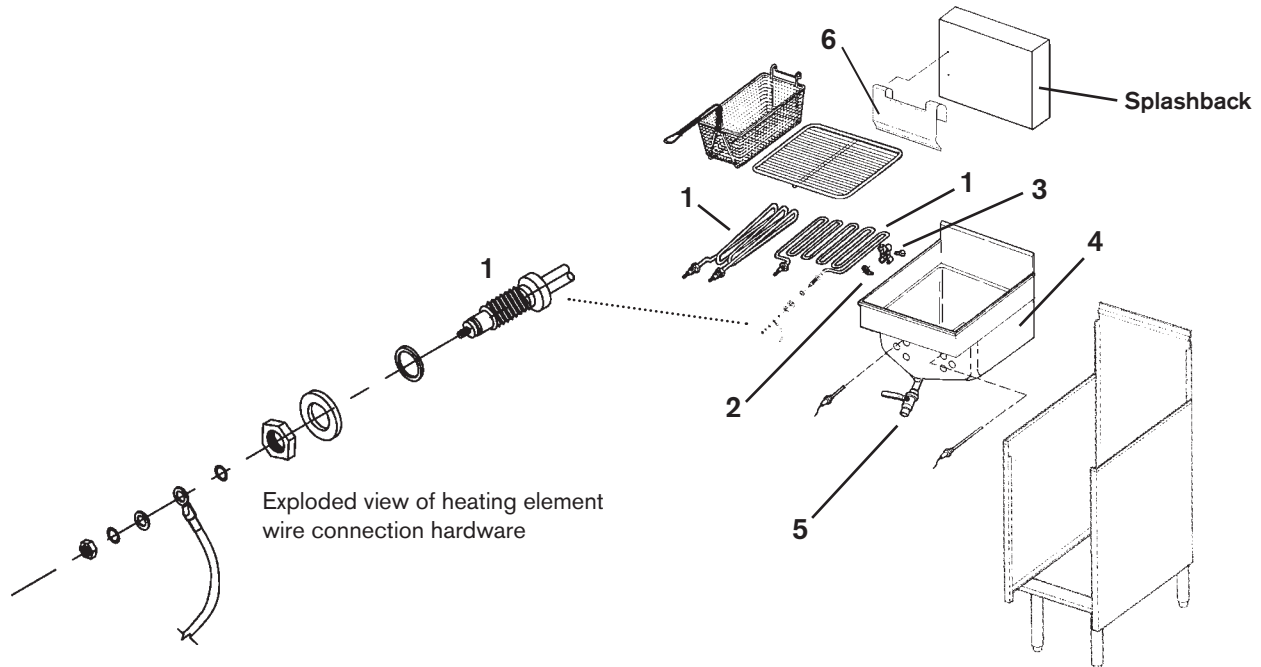

BB CONTROL PANEL 208/240V & 480V

(not shown to scale)

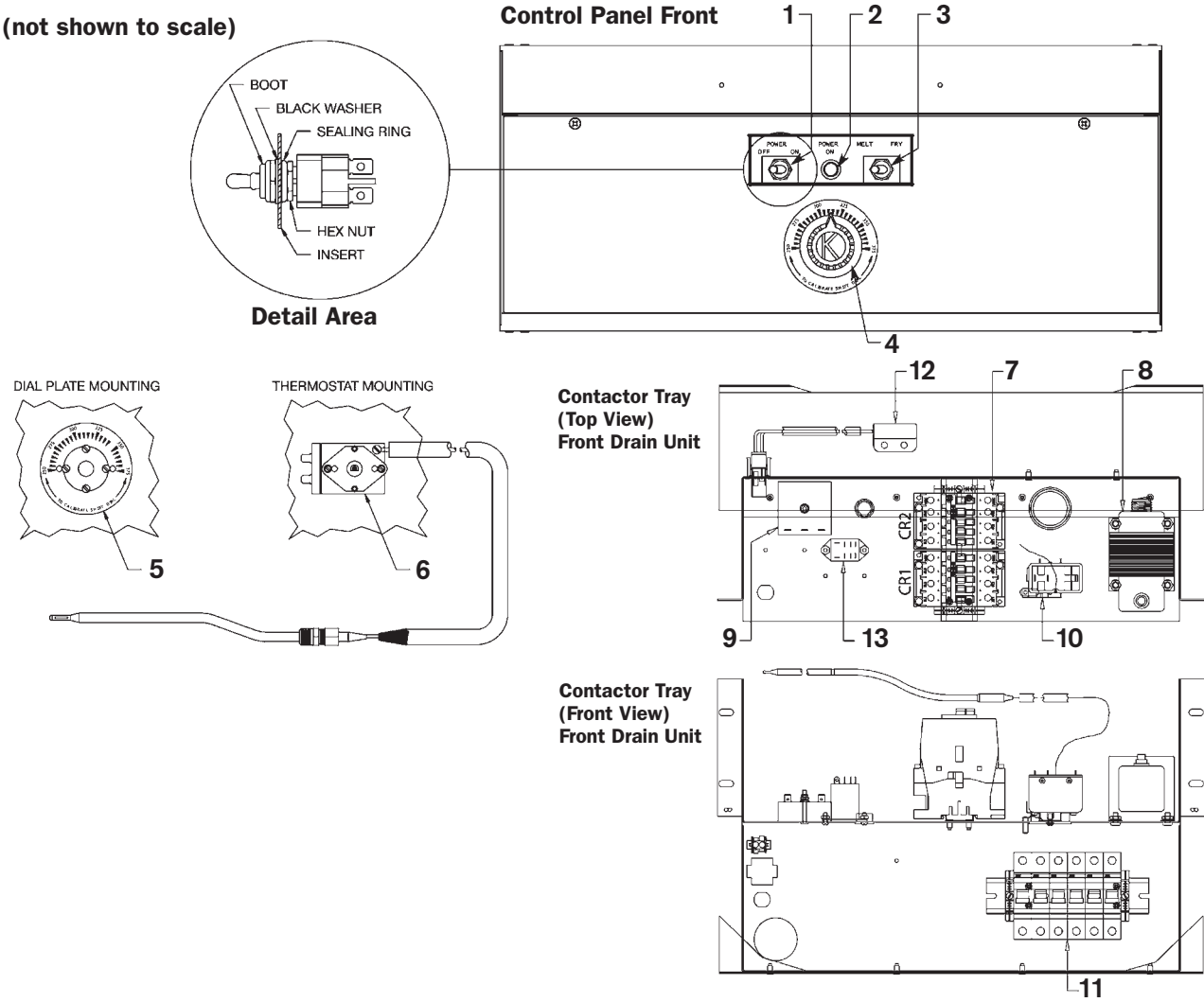

ITEM	DESCRIPTION	P/N	Quantity Per Model					
			10x11	14	18	20	24	34x24
1	SWITCH TOGGLE SEALED ON-OFF	059141	1	1	1	1	1	1
2	INDICATING LIGHT CLEAR ROUND 28V	057863	1	1	1	1	1	1
3	SWITCH TOGGLE SEALED MELT-FRY	059143	1	1	1	1	1	1
4	THERMOSTAT KNOB, BLACK	060612	1	1	1	1	1	1
5	THERMOSTAT DIAL PLATE FRYER 250°-375°	058037	1	1	1	1	1	1
6	THERMOSTAT	031099	1	1	1	1	1	1
7	CONTACTOR 3 POLE 30 AMP	033896	2 ^(208-480V)	2 ^(480V)	2 ^(480V)	2 ^(480V)		4 ^(480V)
	CONTACTOR 3 POLE 40 AMP	033898		2				
	CONTACTOR 3 POLE 50 AMP	033899			2	2		4
	CONTACTOR 4 POLE 40 AMP	053383					2 ^(480V)	
8	TRANSFORMER STEP DOWN	056037	1	1	1	1	1	1
9	FAT MELT INFINITE CONTROL	037470	1	1	1	1	1	1
10	HIGH LIMIT RESETTABLE	060806	1	1	1	1	1	1
11	CIRCUIT BREAKER 16 AMP 1 POLE (208-240V)	057338	3					
	CIRCUIT BREAKER 32 AMP 1 POLE (208-240V)	033885		6				
	CIRCUIT BREAKER 40 AMP 1 POLE (208-240V)	033881			6	6	8	10
	CIRCUIT BREAKER 10 AMP 1 POLE (480V)	057336	3					
	CIRCUIT BREAKER 16 AMP 1 POLE (480V)	057338		6				
	CIRCUIT BREAKER 20 AMP 1 POLE (480V)	033920			6	6	8	10
12	MAGNETIC REED SWITCH (Rear Drain Fryers Only)	053777	1	1	1	1	1	2
13	RELAY (Rear Drain Fryers Only)	030844	1	1	1	1	1	1

TS CONTROL PANEL 208/240V & 480V with ROCKER SWITCHES

(not shown to scale)

Control Panel Front

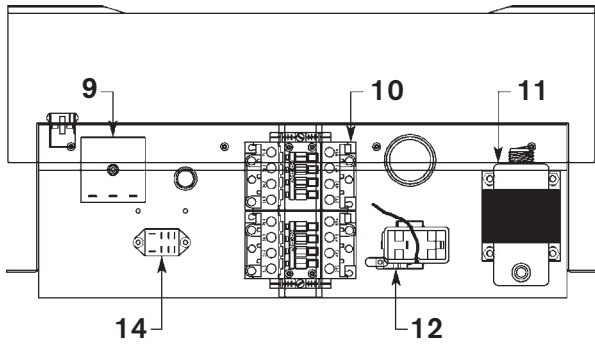
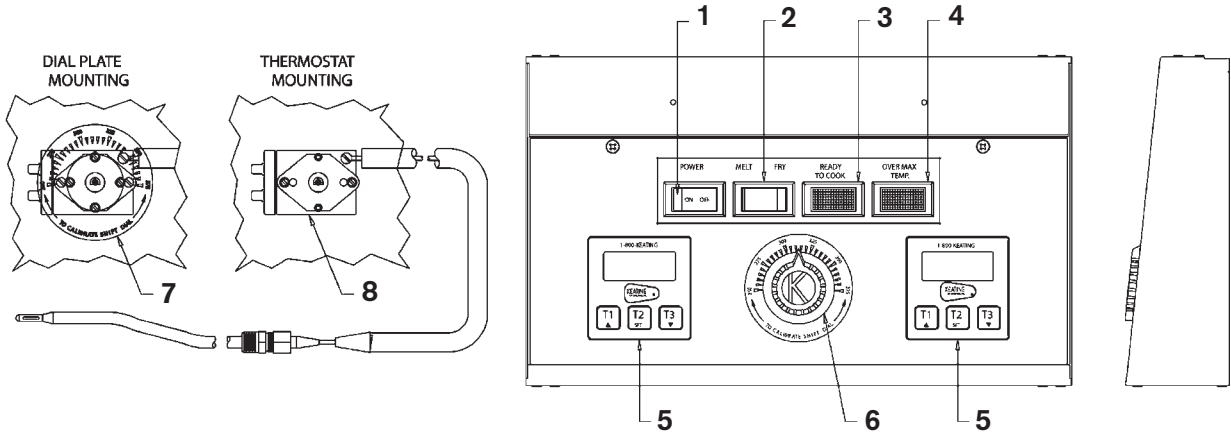

Contactor Tray (Top View) Front Drain Unit

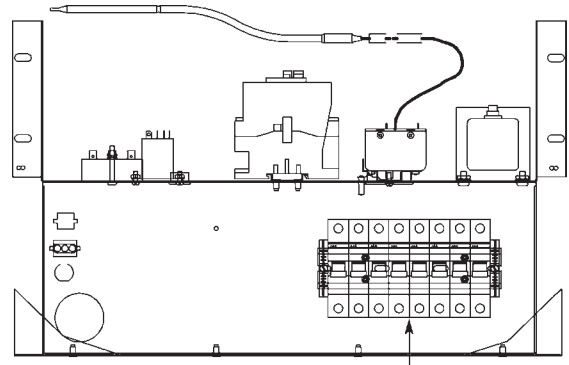

Contactor Tray (Front View) Front Drain Unit 13

ITEM	DESCRIPTION	P/N	Quantity Per Model					
			10x11	14	18	20	24	34x24
1	SWITCH ROCKER ON-OFF DPST	035030	1	1	1	1	1	1
2	SWITCH ROCKER SPDT WHITE	025726	1	1	1	1	1	1
3	INDICATING LIGHT GREEN 28V	021255	1	1	1	1	1	1
4	INDICATING LIGHT RED 28V	021209	1	1	1	1	1	1
5	TIMER DIGITAL 24V/120VAC	056921	2	2	2	2	2	2
6	THERMOSTAT KNOB, BLACK	060612	1	1	1	1	1	1
7	THERMOSTAT DIAL PLATE FRYER 250°-375°P	058037	1	1	1	1	1	1
8	THERMOSTAT	031099	1	1	1	1	1	1
9	FAT MELT INFINITE CONTROL	037470	1	1	1	1	1	1
10	CONTACTOR 3 POLE 30 AMP	033896	2 ^(208-480V)	2 ^(480V)			4 ^(480V)	4 ^(480V)
	CONTACTOR 3 POLE 50 AMP	033899		2			4	4
	CONTACTOR 4 POLE 30 AMP	053385			2 ^(480V)	2 ^(480V)		
	CONTACTOR 4 POLE 40 AMP	053383			2	2		
11	TRANSFORMER STEP DOWN 24VAC 75VA	056037	1	1	1	1	1	1
12	HIGH LIMIT RESETTABLE	060806	1	1	1	1	1	1
13	CIRCUIT BREAKER 16 AMP 1 POLE (208-240V)	057338						
	CIRCUIT BREAKER 25 AMP 1 POLE (208-240V)	033525	3					
	CIRCUIT BREAKER 32 AMP 1 POLE (208-240V)	033885						
	CIRCUIT BREAKER 40 AMP 1 POLE (208-240V)	033881		6	8	8	10	
	CIRCUIT BREAKER 13 AMP 1 POLE (480V)	057337	3					
	CIRCUIT BREAKER 20 AMP 1 POLE (480V)	033920		6	8	8	10	12
14	RELAY	030844	1	1	2	2	1	1
15*	MAGNETIC REED SWITCH	053777	1	1	1	1	1	2
16*	CIRCUIT BREAKER BASKET LIFT 4AMP 1 POLE	058219		1	1	1	1	

*Not Shown, Rear Drain Fryers Only

TS CONTROL PANEL 208/240V & 480V with TOGGLE SWITCHES

(not shown to scale)

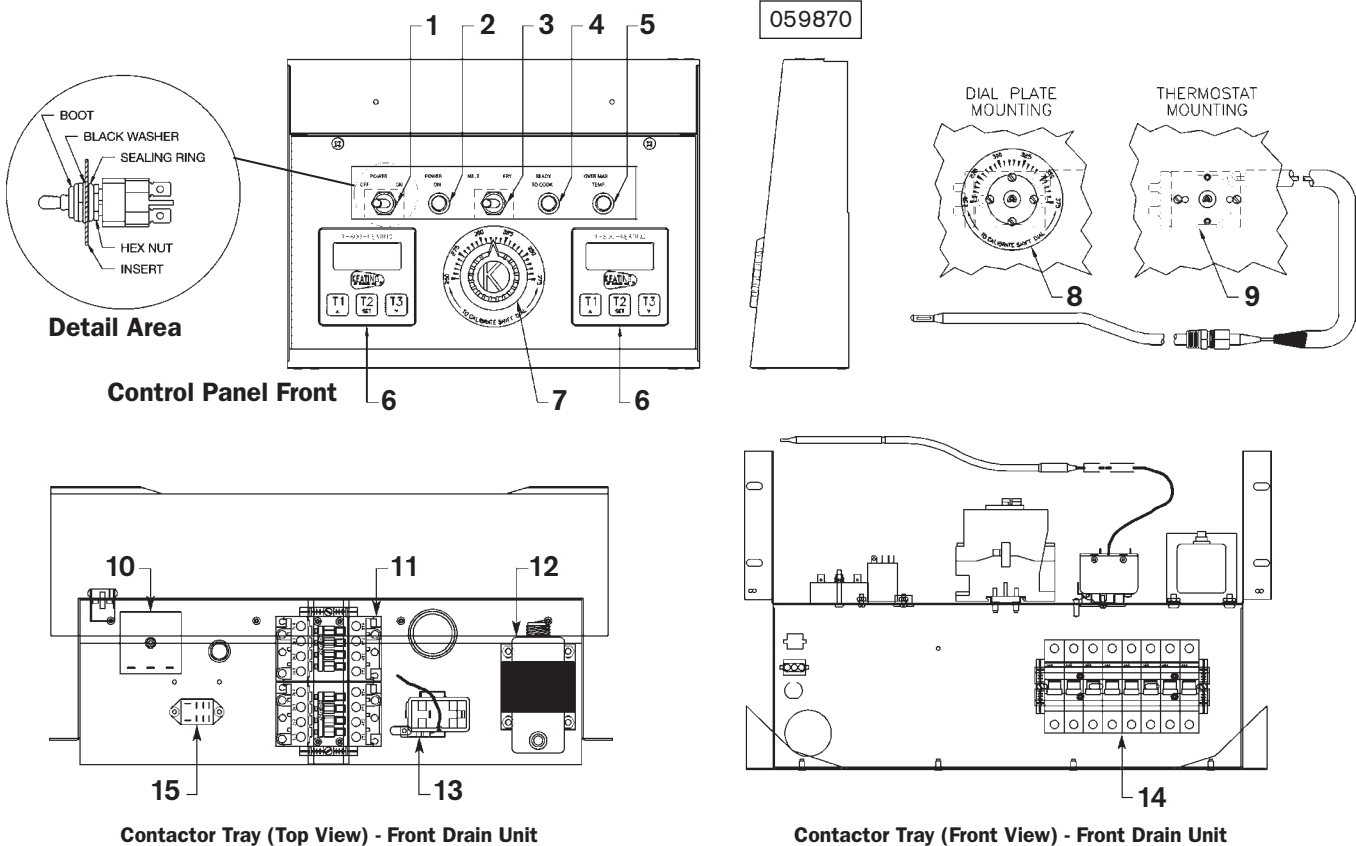

ITEM	DESCRIPTION	P/N	Quantity Per Model				
			10x11	14	18	20	24
1	SWITCH TOGGLE SEALED ON-OFF	059141	1	1	1	1	1
2	INDICATING LIGHT CLEAR ROUND 28V	057863	1	1	1	1	1
3	SWITCH TOGGLE SEALED MELT-FRY	059143	1	1	1	1	1
4	INDICATING LIGHT GREEN ROUND	056587	1	1	1	1	1
5	INDICATING LIGHT RED ROUND	057861	1	1	1	1	1
6	TIMER DIGITAL 24V/120V	056921	2	2	2	2	2
7	THERMOSTAT KNOB, BLACK	060612	1	1	1	1	1
8	THERMOSTAT DIAL PLATE FRYER 250°-375°	058037	1	1	1	1	1
9	THERMOSTAT	031099	1	1	1	1	1
10	FAT MELT INFINITE CONTROL	037470	1	1	1	1	1
11	CONTACTOR 3 POLE 30 AMP	033896	2 ^(208-480V)	2 ^(480V)			4 ^(480V)
	CONTACTOR 3 POLE 50 AMP	033899		2			4
	CONTACTOR 4 POLE 30 AMP	053385			2 ^(480V)	2 ^(480V)	
	CONTACTOR 4 POLE 40 AMP	053383			2	2	
12	TRANSFORMER STEP DOWN 24VAC 75VA	056037	1	1	1	1	1
13	HIGH LIMIT RESETTABLE	060806	1	1	1	1	1
14	CIRCUIT BREAKER 16 AMP 1 POLE (208-240V)	057338					
	CIRCUIT BREAKER 25 AMP 1 POLE (208-240V)	033525	3				
	CIRCUIT BREAKER 32 AMP 1 POLE (208-240V)	033885					
	CIRCUIT BREAKER 40 AMP 1 POLE (208-240V)	033881		6	8	8	10
	CIRCUIT BREAKER 13 AMP 1 POLE (480V)	057337	3				
	CIRCUIT BREAKER 20 AMP 1 POLE (480V)	033920		6	8	8	10
15	RELAY	030844	1	1	2	2	1
16*	MAGNETIC REED SWITCH	053777	1	1	1	1	1
17*	CIRCUIT BREAKER BASKET LIFT 4AMP 1 POLE	058219		1	1	1	1

*Not Shown, Rear Drain Fryers Only

34x24 TS CONTROL PANEL 208/240V & 480V with TOGGLE SWITCHES

(not shown to scale)

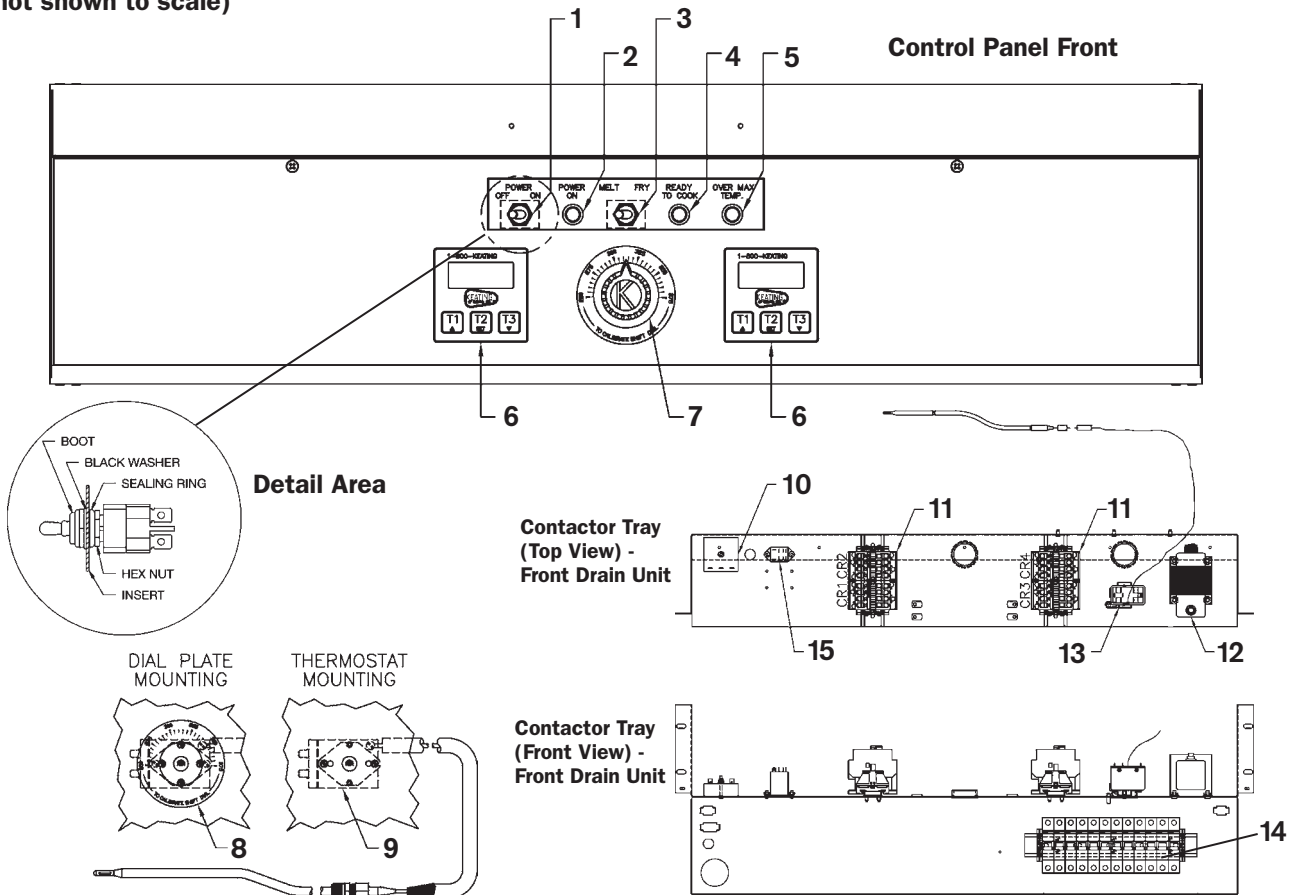

ITEM	DESCRIPTION	P/N	34x24
1	SWITCH TOGGLE SEALED ON-OFF	059141	1
2	INDICATING LIGHT CLEAR ROUND 28V	057863	1
3	SWITCH TOGGLE SEALED MELT-FRY	059143	1
4	INDICATING LIGHT GREEN ROUND	056587	1
5	INDICATING LIGHT RED ROUND	057861	1
6	TIMER DIGITAL 24V/120V	056921	2
7	THERMOSTAT KNOB, BLACK	060612	1
8	THERMOSTAT DIAL PLATE FRYER 250°-375°	058037	1
9	THERMOSTAT	031099	1
10	FAT MELT INFINITE CONTROL	037470	1
11	CONTACTOR 3 POLE 30 AMP	033896	4 (480V)
	CONTACTOR 3 POLE 50 AMP	033899	4
	CONTACTOR 4 POLE 30 AMP	053385	
	CONTACTOR 4 POLE 40 AMP	053383	
12	TRANSFORMER STEP DOWN 24VAC 75VA	056037	1
13	HIGH LIMIT RESETTABLE	060806	1
14	CIRCUIT BREAKER 16 AMP 1 POLE (208-240V)	057338	
	CIRCUIT BREAKER 25 AMP 1 POLE (208-240V)	033525	
	CIRCUIT BREAKER 32 AMP 1 POLE (208-240V)	033885	
	CIRCUIT BREAKER 40 AMP 1 POLE (208-240V)	033881	
	CIRCUIT BREAKER 13 AMP 1 POLE (480V)	057337	
	CIRCUIT BREAKER 20 AMP 1 POLE (480V)	033920	12
15	RELAY	030844	1
16*	MAGNETIC REED SWITCH	053777	2
17*	CIRCUIT BREAKER BASKET LIFT 4AMP 1 POLE	058219	

*Not Shown, Rear Drain Fryers Only

34x24 CPU CONTROL PANEL 208/240V with TOGGLE SWITCH

(not shown to scale)

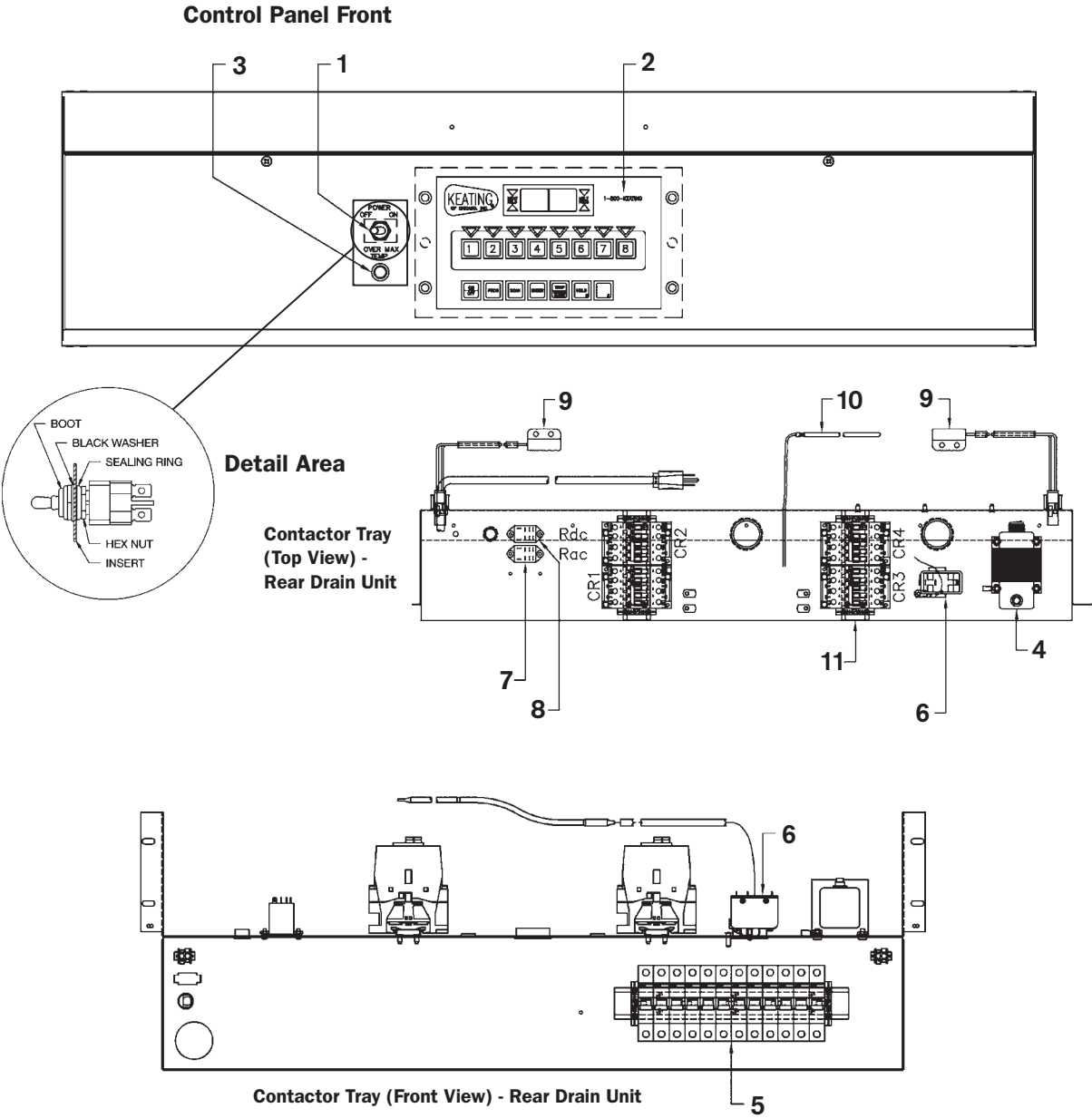

ITEM	DESCRIPTION	P/N	34x24
1	SWITCH TOGGLE SEALED ON-OFF	059141	1
2	COMPUTER	031125	1
3	INDICATING LIGHT RED ROUND	057861	1
4	TRANSFORMER STEP DOWN 24VAC 75VA	056037	1
5	CIRCUIT BREAKER 40 AMP 1 POLE (208-240V)	033881	12
6	HIGH LIMIT RESETTABLE	060806	1
7	RELAY DPDT 24 VAC	030844	1
8	RELAY DPDT 24 VDC	017673	1
9	MAGNETIC REED SWITCH	053777	2
10	COMPUTER PROBE	004776	1
11	CONTACTOR 50 AMP 3 POLE	033899	4

CPU CONTROL PANEL 208/240V with ROCKER SWITCHES

(not shown to scale)

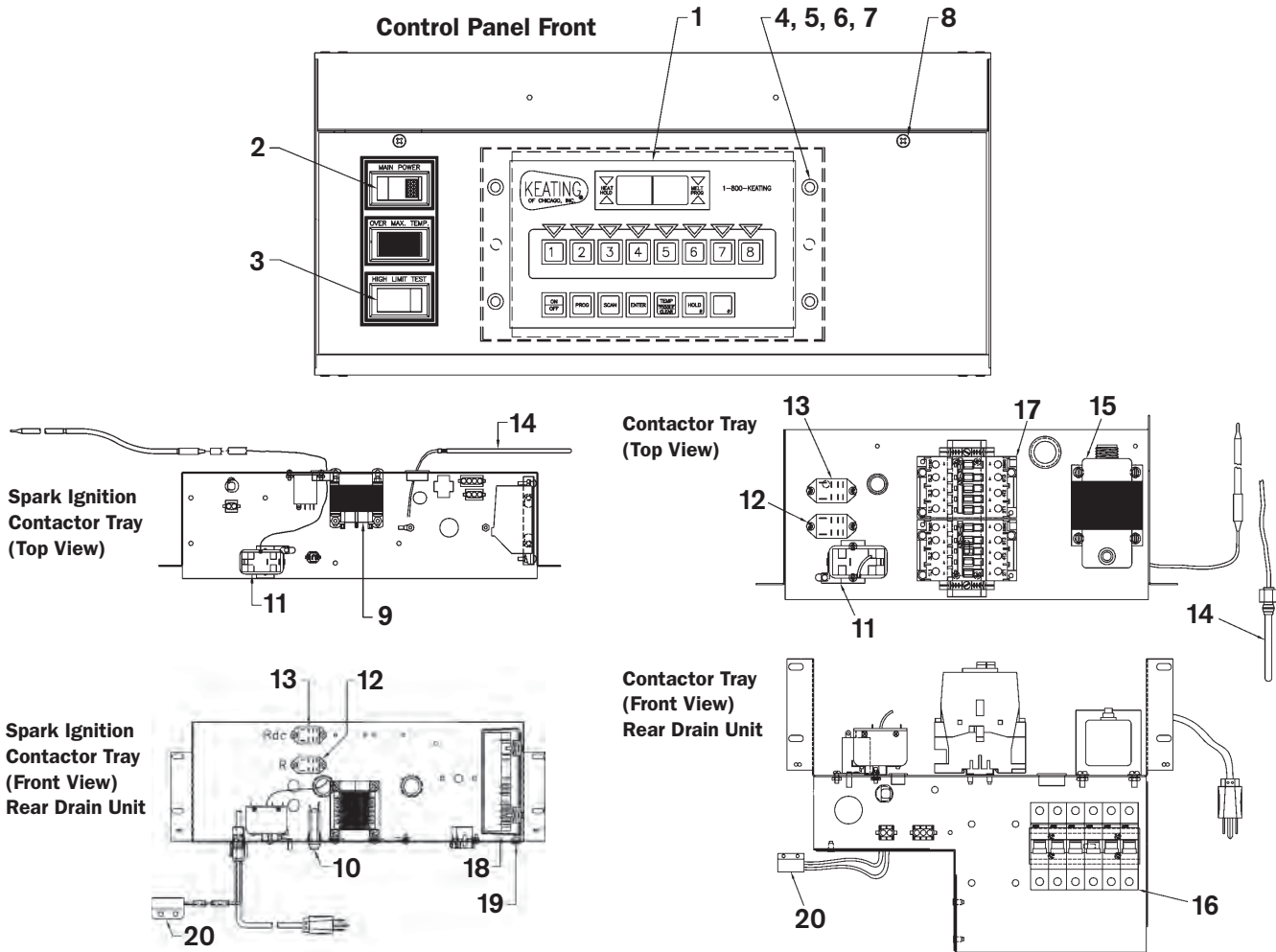

ITEM	DESCRIPTION	P/N	QTY
1	COMPUTER	031125	1
2	SWITCH ROCKER ILLUMINATED GREEN	032242	1
3	SWITCH ROCKER MOMENTARY	015384	1
4	SCREW CARRIAGE 10 - 24 x 1/2"	027490	4
5	WASHER INTERNAL TOOTH LOCK #10	011562	4
6	WASHER .190 I.D. X .563 O.D.	013217	4
7	NUT HEX #10 - 24	009053	4
8	SCREW PAN HEAD PHILLIPS 10 - 24 x 1/2"	030850	2
9	TRANSFORMER STEP DOWN 24VAC 80VA	024032	1
10	CIRCUIT BREAKER 3 AMP 1 POLE (250V)	053338	1
11	HIGH LIMIT MANUAL RESET	060806	1
12	RELAY DPDT 24VAC	030844	2
13	RELAY DPDT 24VDC	017673	2
14	COMPUTER PROBE	004776	1
15	TRANSFORMER STEP DOWN 24VAC 75VA	056037	1
16	CIRCUIT BREAKER 40 AMP 1 POLE (208-240V)	033881	6
17	CONTACTOR 50 AMP 1 POLE	033899	2
18*	SPARK IGNITION MODULE 24VAC	058439	1
19*	BRACKET SPARK IGNITION MODULE	056000	1
20**	MAGNETIC REED SWITCH	053777	1

*Spark Ignition Model Only
 **Rear Drain Fryers Only

BASKET LIFT POWER SUPPLY BOX & BASKET LIFT ASSEMBLY

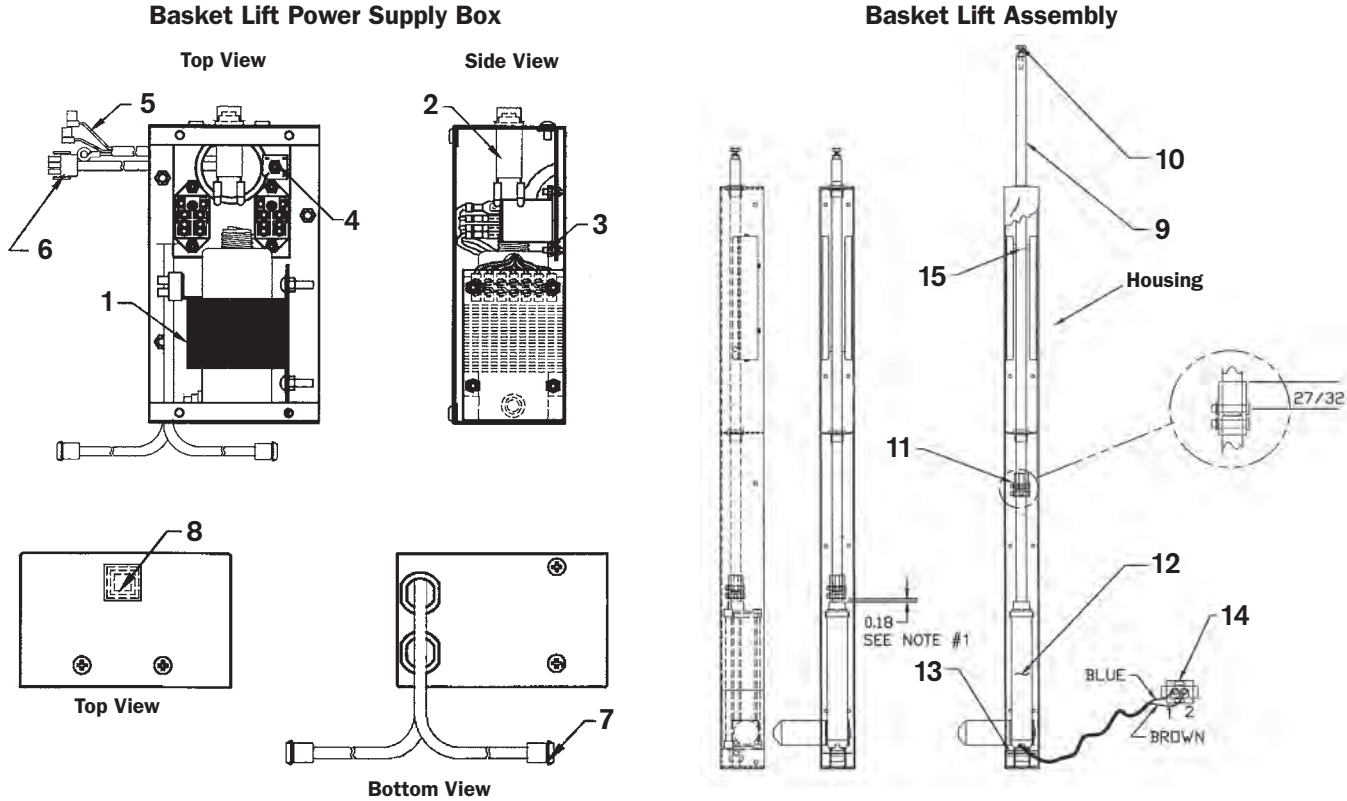

- NOTES:**
1. A minimum distance of 3/16" and maximum distance of 1/4" should be maintained when actuator is at full downward stroke. Item 11 should never be bottomed on item 12 when in this location.
 2. Actuator shaft should travel 6 1/2" upward from lowest position.
 3. Distance is to be measured when actuator is powered.
 4. Apply light coating of food grade grease to Item 9 on entire shaft inside housing.

ITEM	DESCRIPTION	P/N	QTY
1	TRANSFORMER 120/208/240/480V	056036	1
2*	CIRCUIT BREAKER 3A/250V	053338	1
3	RELAY DPDT 24V AC	030844	2
4	RECTIFIER	018321	1
5	POWER CORD	021289	1
6	CONNECTION 3 CIRCUITS PLUG	032210	1
	CONNECTOR CONTACT PIN MALE	028309	3
7	CONNECTOR 2 CIRCUIT CAP	032207	2
	CONNECTOR CONTACT PIN FEMALE	028308	2
8	COVER FOR CIRCUIT BREAKER	054664	1
9	PUSH ROD	018096	1
10	SCREW 1/4"-20" X 1 1/4"	021091	1
	HEX NUT 1/4-20	016383	1
11	COUPLER ACTUATOR BL	054525	1
	RETAINING RING	054540	2
	PIN COUPLER ACTUATOR BL	054503	2
12	ACTUATOR 24V DC	054510	1
13	SHAFT ACTUATOR LOWER BL S/S	054522	1
14	CONNECTOR 2 CIRCUIT PLUG	032208	1
	CONNECTOR CONTACT PIN MALE	028309	2
15	PIN BASKET LIFT NON ROTATIONAL	054760	1

*This circuit breaker can be found under the control panel on newer units.

BASKET LIFT POWER SUPPLY BOX 2007 (CPU & NON-CPU)

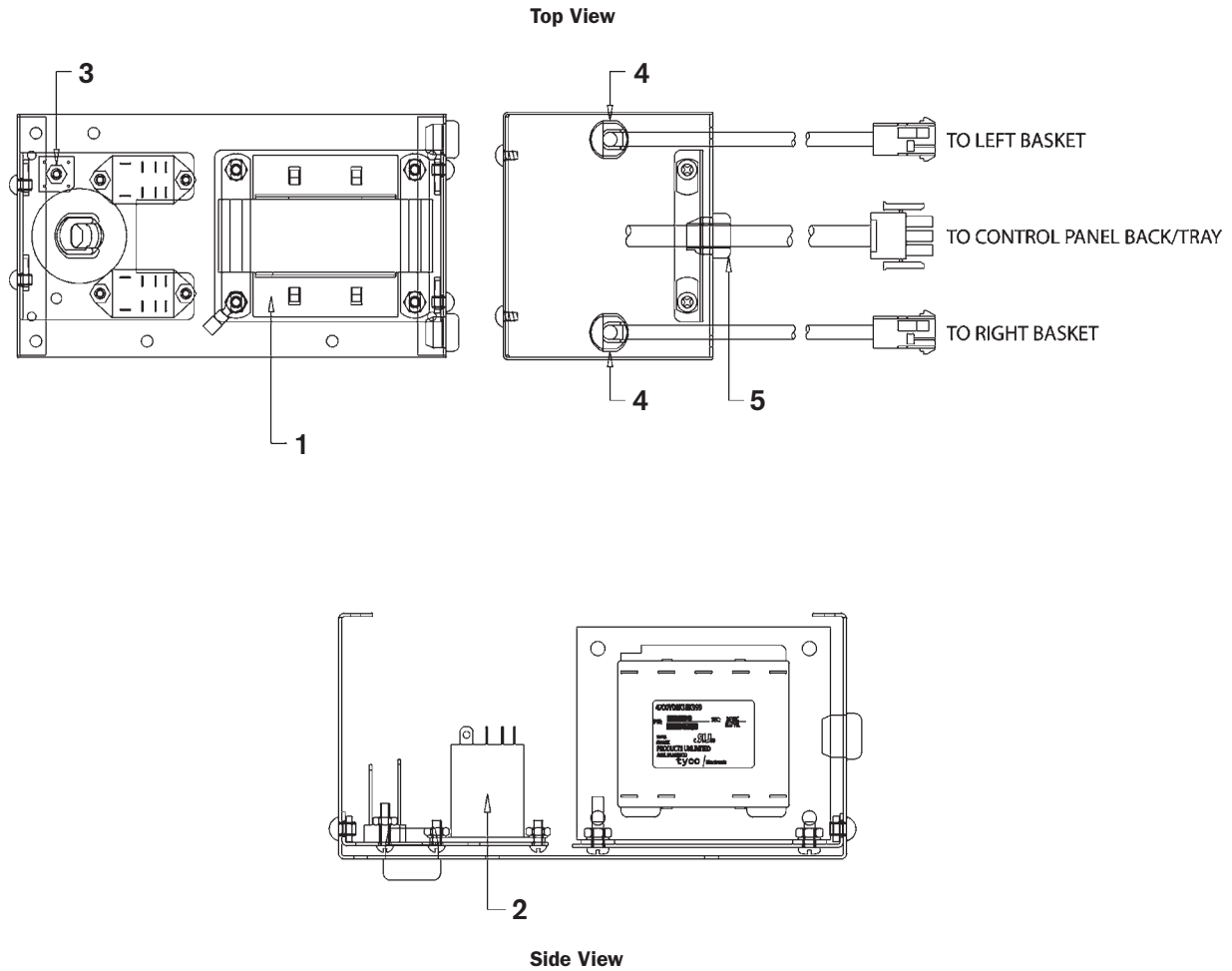

ITEM	DESCRIPTION	P/N	QTY
1	TRANSFORMER STEPDOWN 24VAC 100VA	058359	1
2	RELAY DPDT 24VAC	030844	2
	RELAY DPDT 24VDC (CPU MODEL)	017673	2
3	RECTIFIER 24VDC	018321	1
4	BUSHING STRAIN RELIEF 5/8" HOLE	000470	2
5	BUSHING STRAIN RELIEF 3/4" HOLE	033800	1

NOTE: Circuit breaker is located under the control panel.

■ WIRING DIAGRAMS

NOTE: A separate wiring diagram has been included with this manual and should be saved for troubleshooting and maintaining the fryer. The wiring diagrams in this section cover standard fryers which may or may not match the diagram sent with the fryer. CPU models on pages 34 & 35.

SINGLE BASKET LIFT POWER SUPPLY BOX

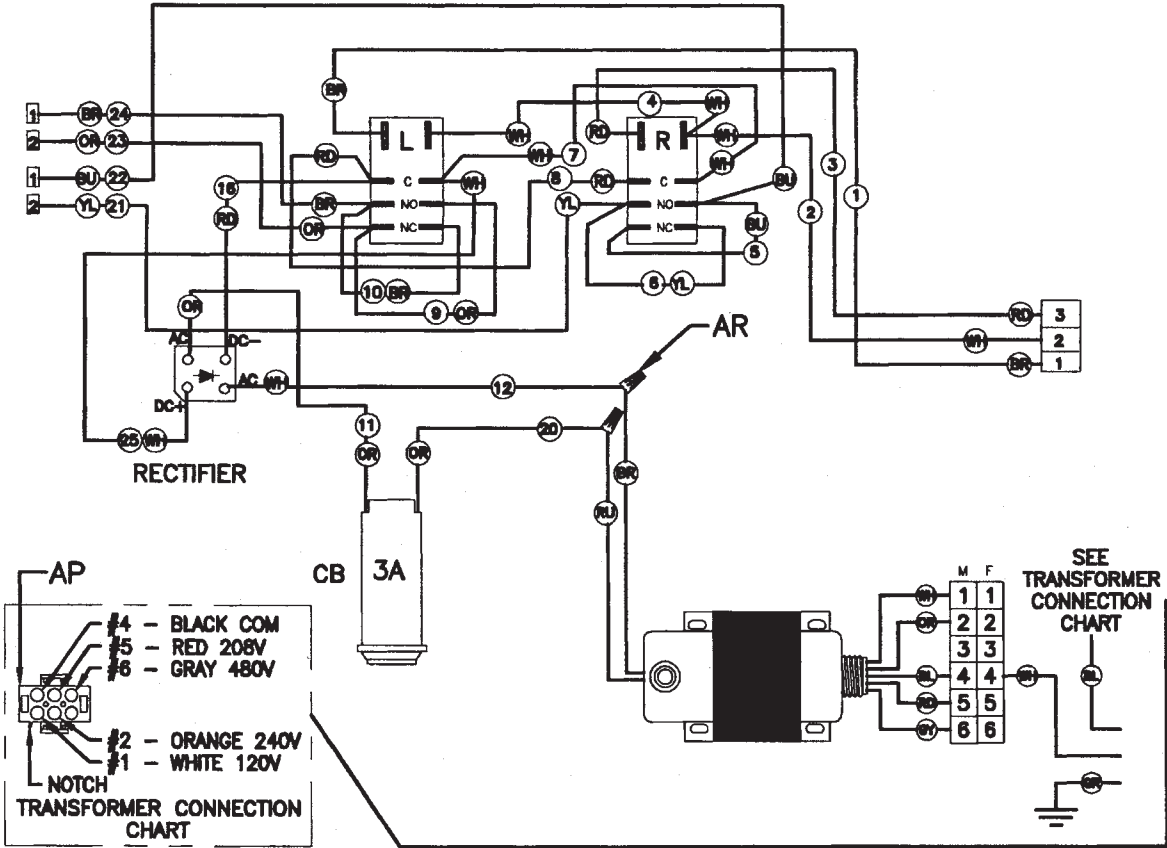

ITEM	DESCRIPTION	P/N	QTY
1	AR WIRENUT GRAY	027134	2
2	AP CONNECTOR 6 CIRCUIT PLUG	028302	1
3	CONNECTOR CONTACT PIN MALE	028309	5

10x11, 14, 18 & 20 BB 2000 208240V & 480V 3 PHASE with REAR DRAIN & SAFE & EASY® FILTER

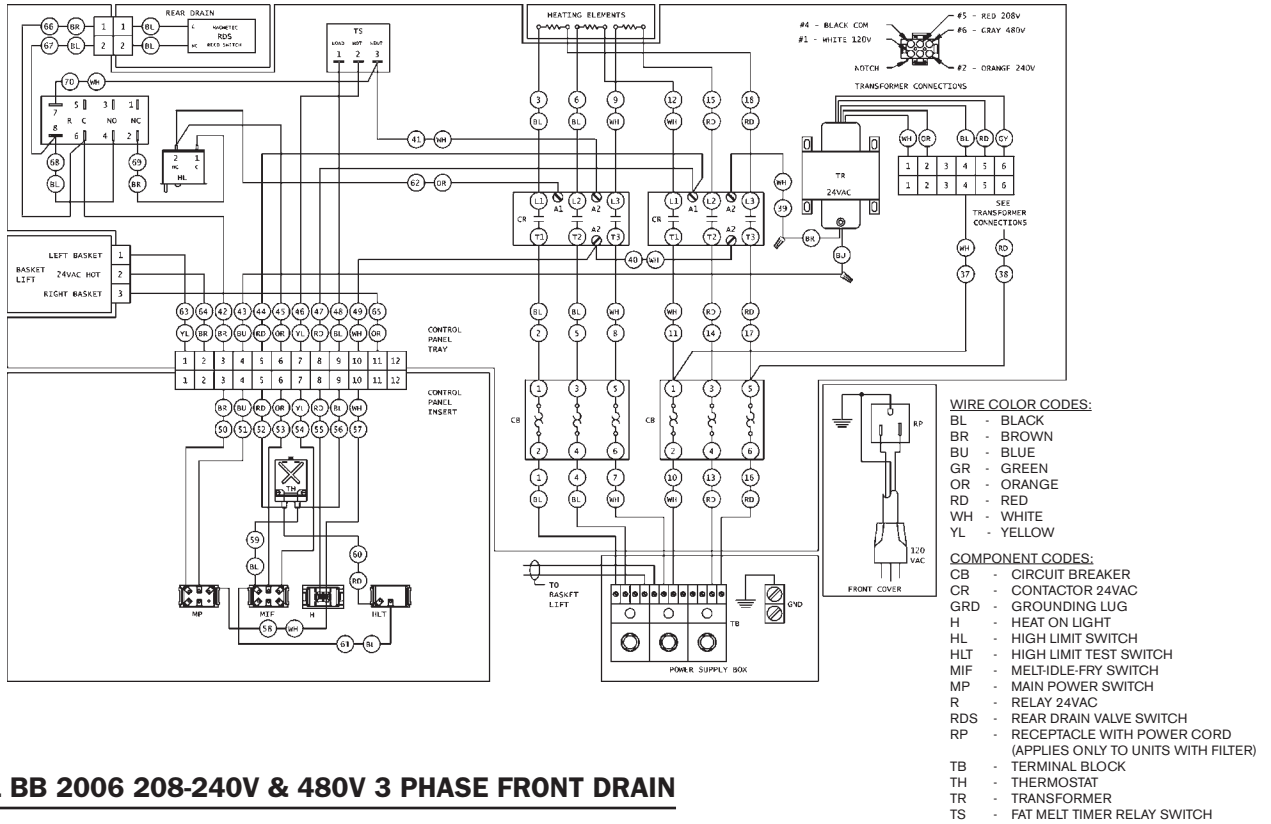

10x11 BB 2006 208-240V & 480V 3 PHASE FRONT DRAIN

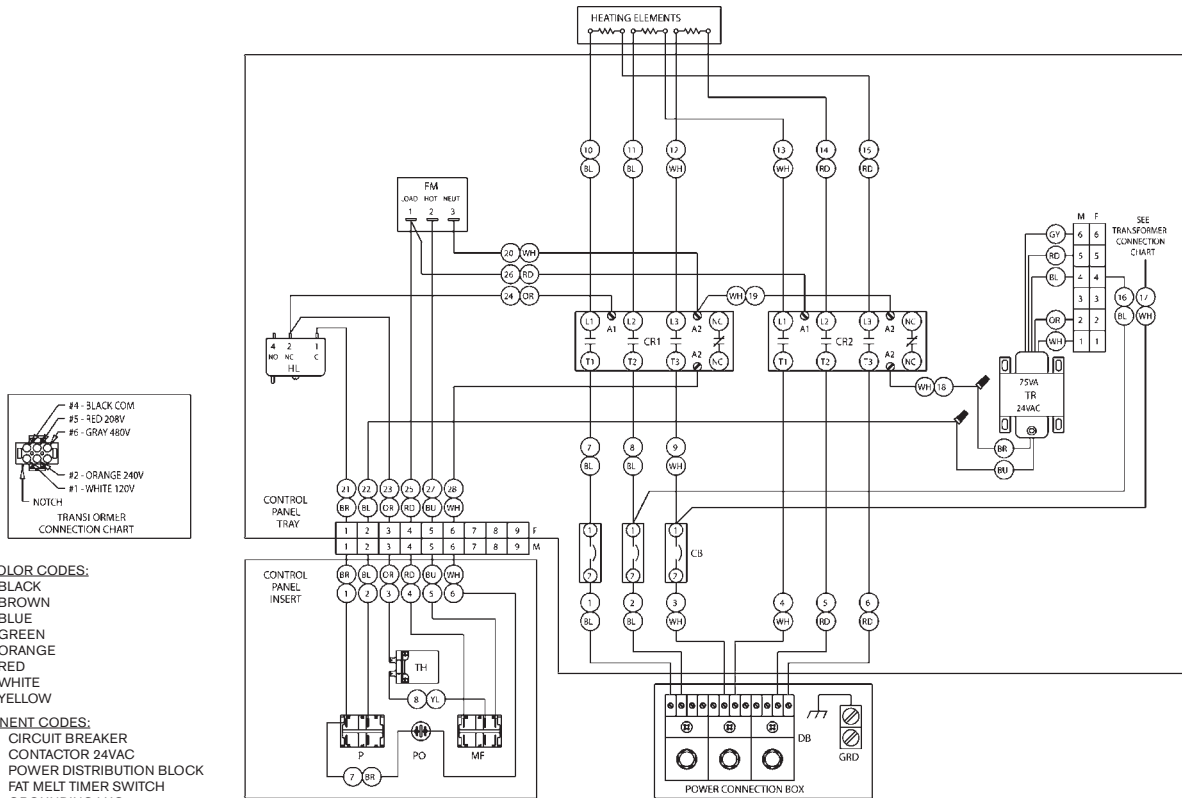

NOTES:
 1. WIRES #1 TO #6 ARE 10 AWG
 #7 TO #15 ARE 12 AWG
 2. ALL OTHER WIRES ARE 18 AWG

10x11 BB 2006 208-240V & 480V 1 PHASE FRONT DRAIN

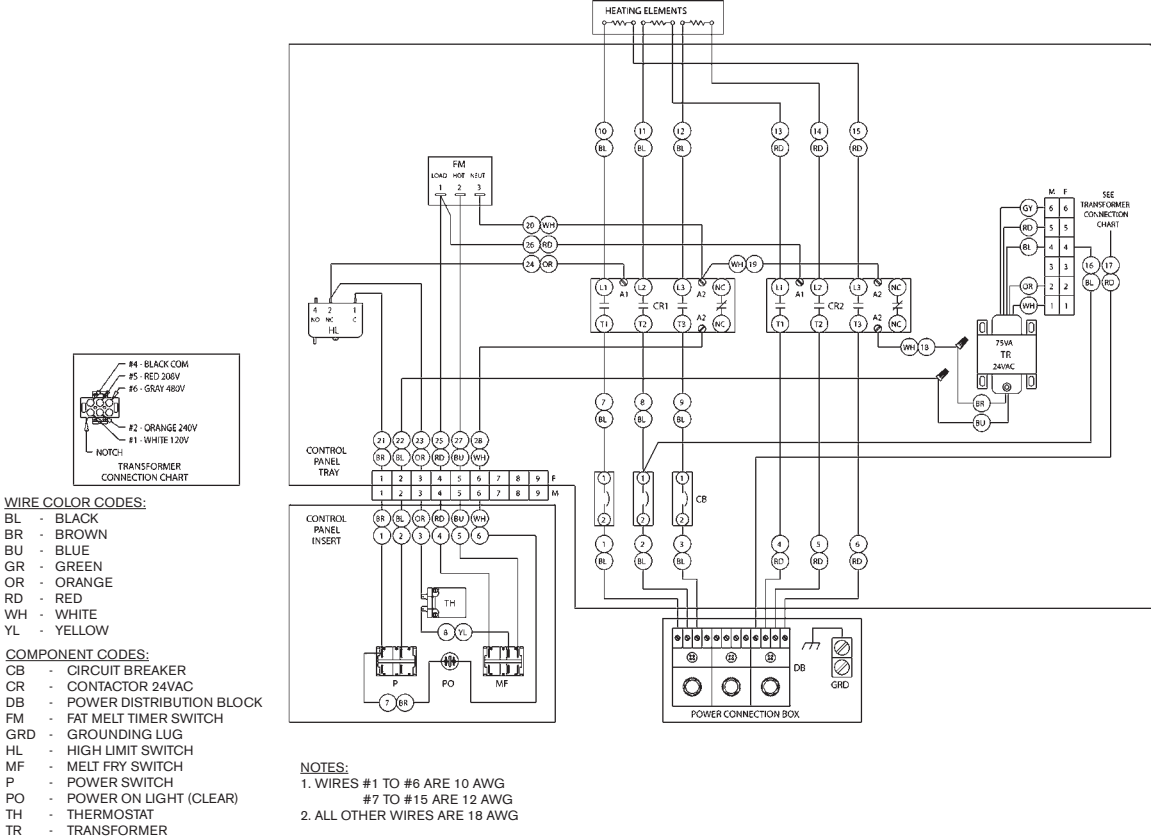

10x11 BB 2006 208-240V & 480V 3 PHASE with REAR DRAIN

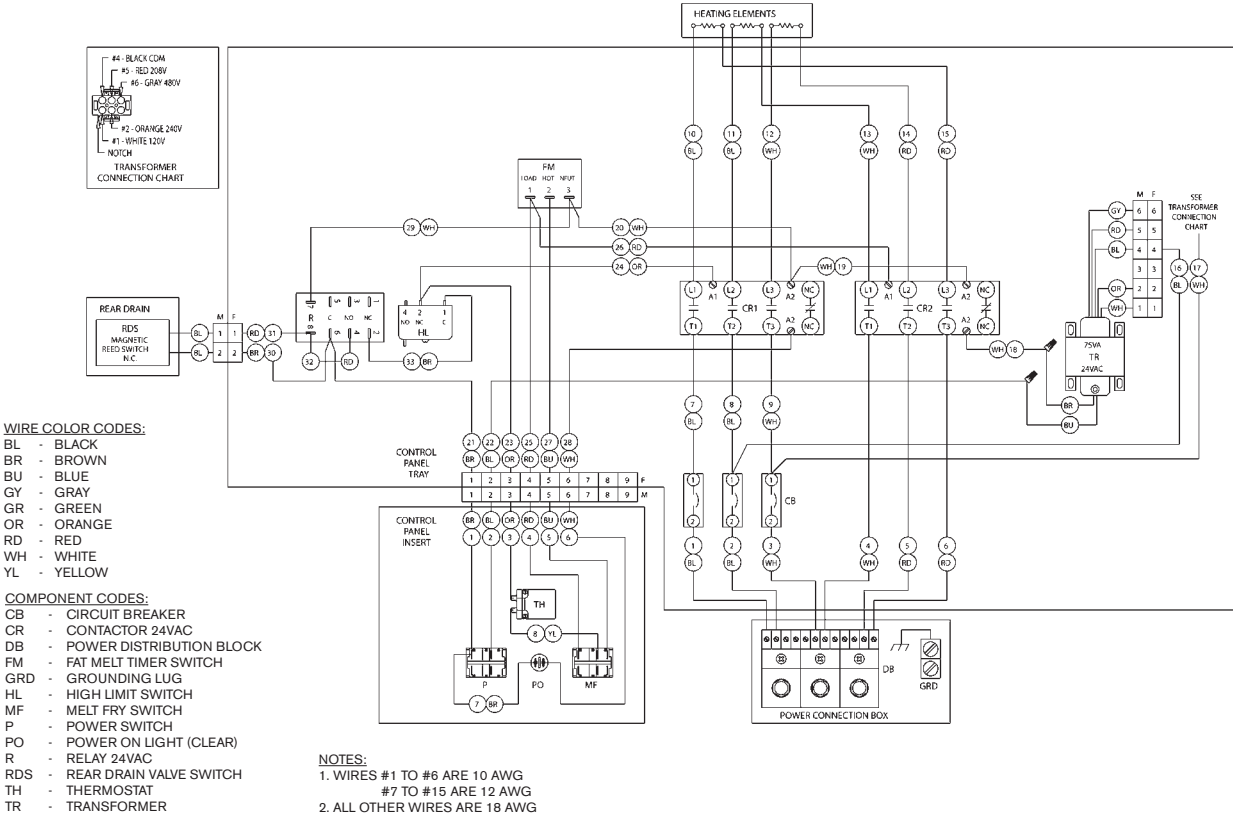

14, 18, 20 BB 2006 208-240V & 480V 1 PHASE FRONT DRAIN

WIRE COLOR CODES:

- BL - BLACK
- BR - BROWN
- BU - BLUE
- GR - GREEN
- OR - ORANGE
- RD - RED
- WH - WHITE
- YL - YELLOW

COMPONENT CODES:

- CB - CIRCUIT BREAKER
- CR - CONTACTOR 24VAC
- DB - POWER DISTRIBUTION BLOCK
- FM - FAT MELT TIMER SWITCH
- GRD - GROUNDING LUG
- HL - HIGH LIMIT SWITCH
- MF - MELT FRY SWITCH
- P - POWER SWITCH
- PO - POWER ON LIGHT (CLEAR)
- TH - THERMOSTAT
- TR - TRANSFORMER

NOTES:

1. WIRES #1 TO #18 ARE 10 AWG
2. ALL OTHER WIRES ARE 18 AWG

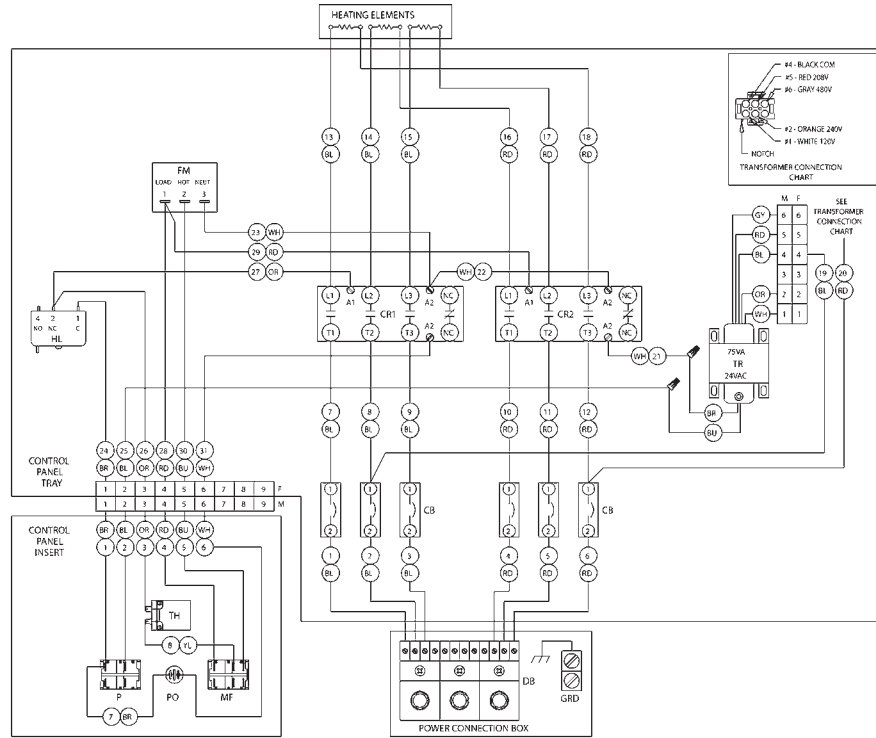

14, 18, 20 BB 2006 208-240V & 480V 3 PHASE FRONT DRAIN

WIRE COLOR CODES:

- BL - BLACK
- BR - BROWN
- BU - BLUE
- GR - GREEN
- OR - ORANGE
- RD - RED
- WH - WHITE
- YL - YELLOW

NOTES:

1. WIRES #1 TO #18 ARE 10 AWG FOR 208/240 VOLT UNITS, AND ARE 12 AWG FOR 480 VOLT UNITS
2. ALL OTHER WIRES ARE 18 AWG

COMPONENT CODES:

- CB - CIRCUIT BREAKER
- CR - CONTACTOR 24VAC
- DB - POWER DISTRIBUTION BLOCK
- FM - FAT MELT TIMER SWITCH
- GRD - GROUNDING LUG
- HL - HIGH LIMIT SWITCH
- MF - MELT FRY SWITCH
- P - POWER SWITCH
- PO - POWER ON LIGHT (WHITE)
- TH - THERMOSTAT
- TR - TRANSFORMER

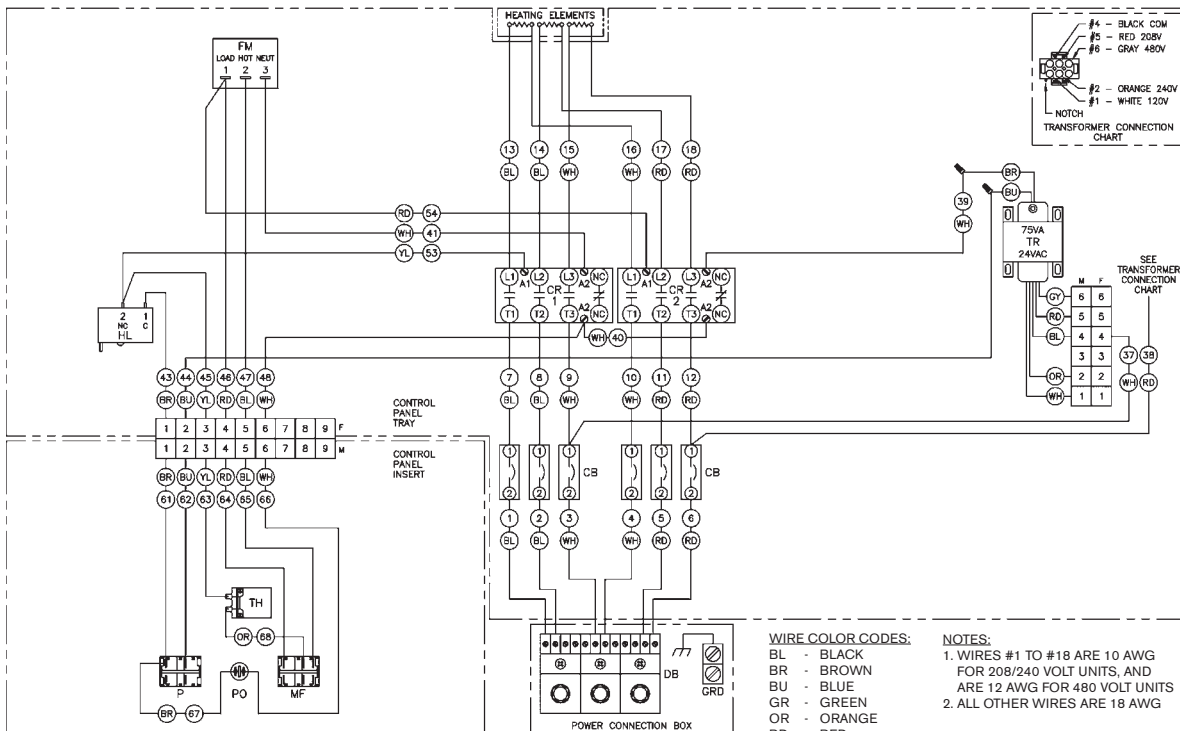

14, 18, 20 BB 2006 208-240V & 480V 3 PHASE with REAR DRAIN & SAFE & EASY® FILTER

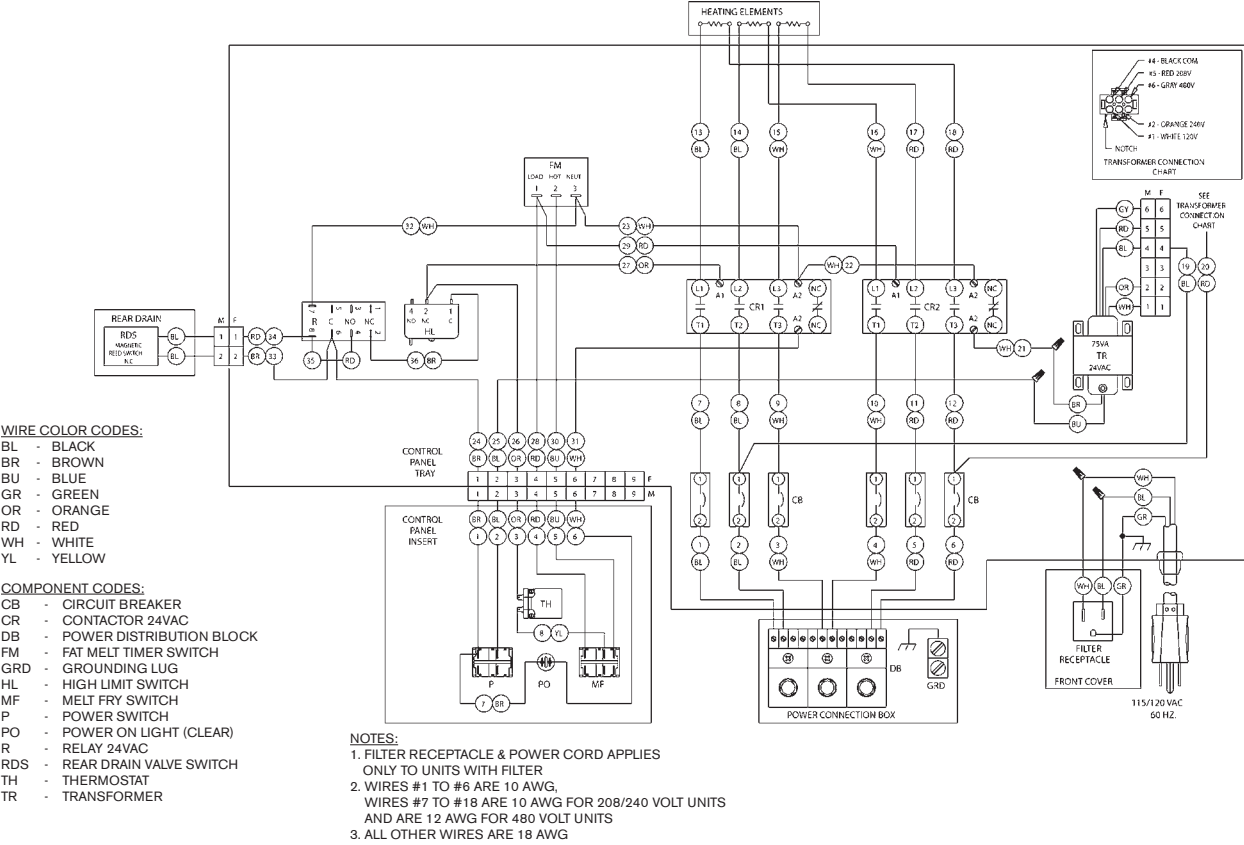

24 BB 2006 208-240V & 480V 3 PHASE FRONT DRAIN

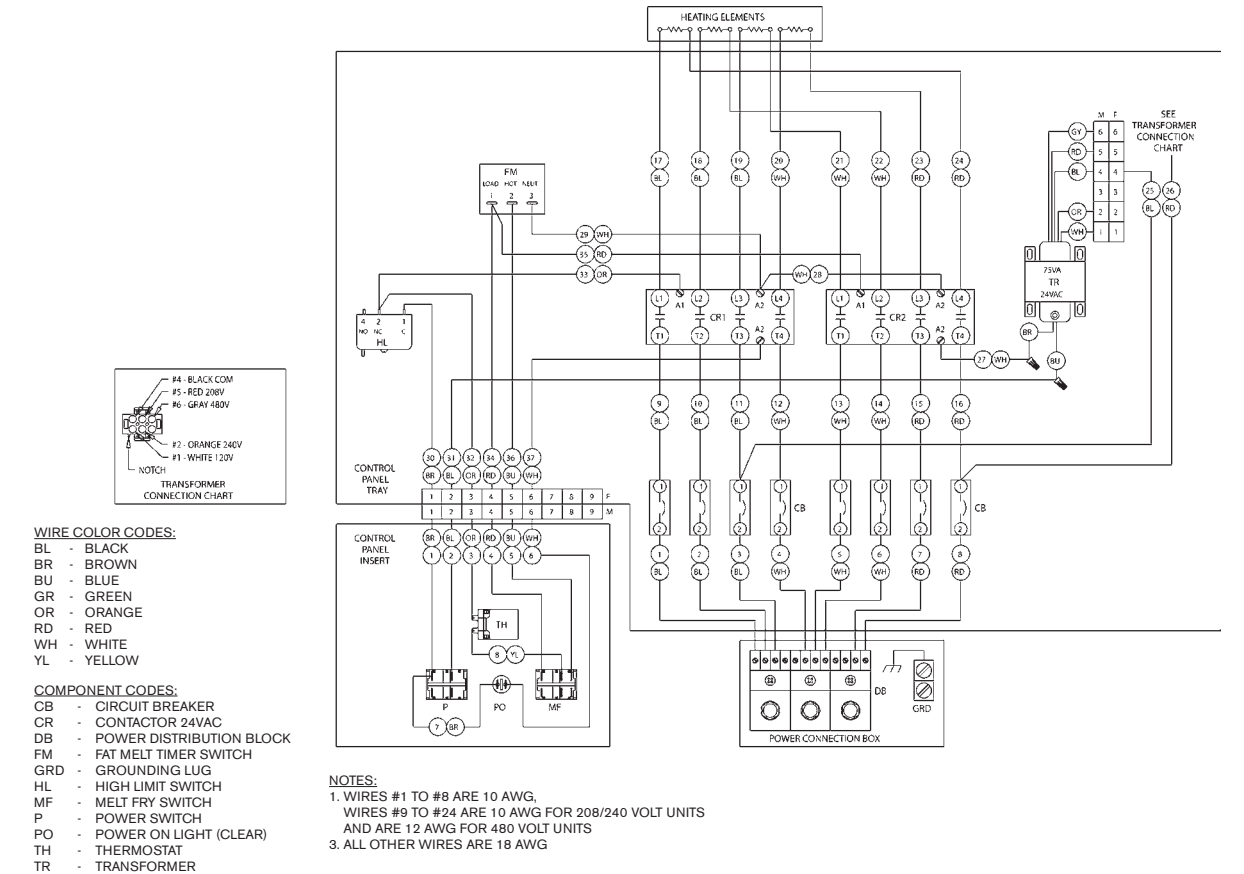

24 BB 2006 208-240V & 480V 3 PHASE with REAR DRAIN and SAFE & EASY® FILTER

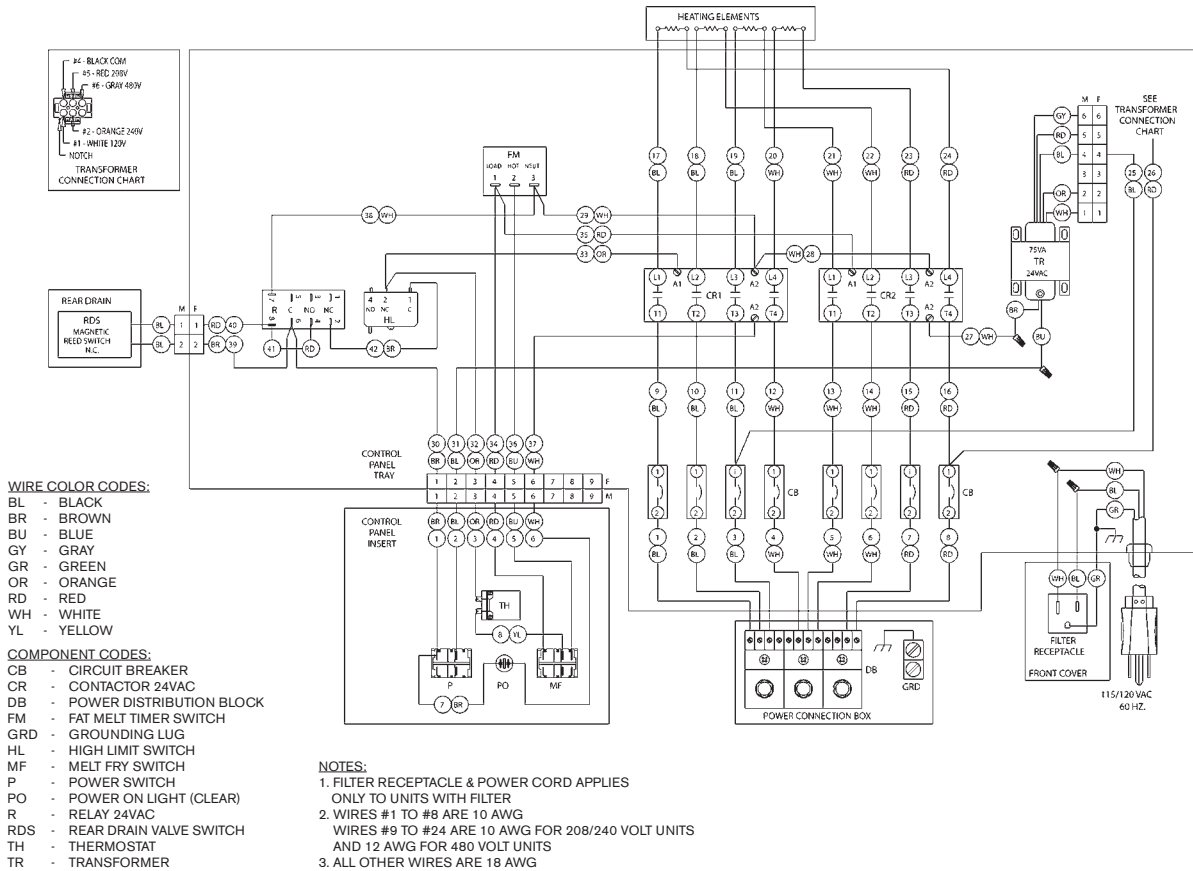

34x24 BB 2006 208-240V & 480V 3 PHASE FRONT DRAIN

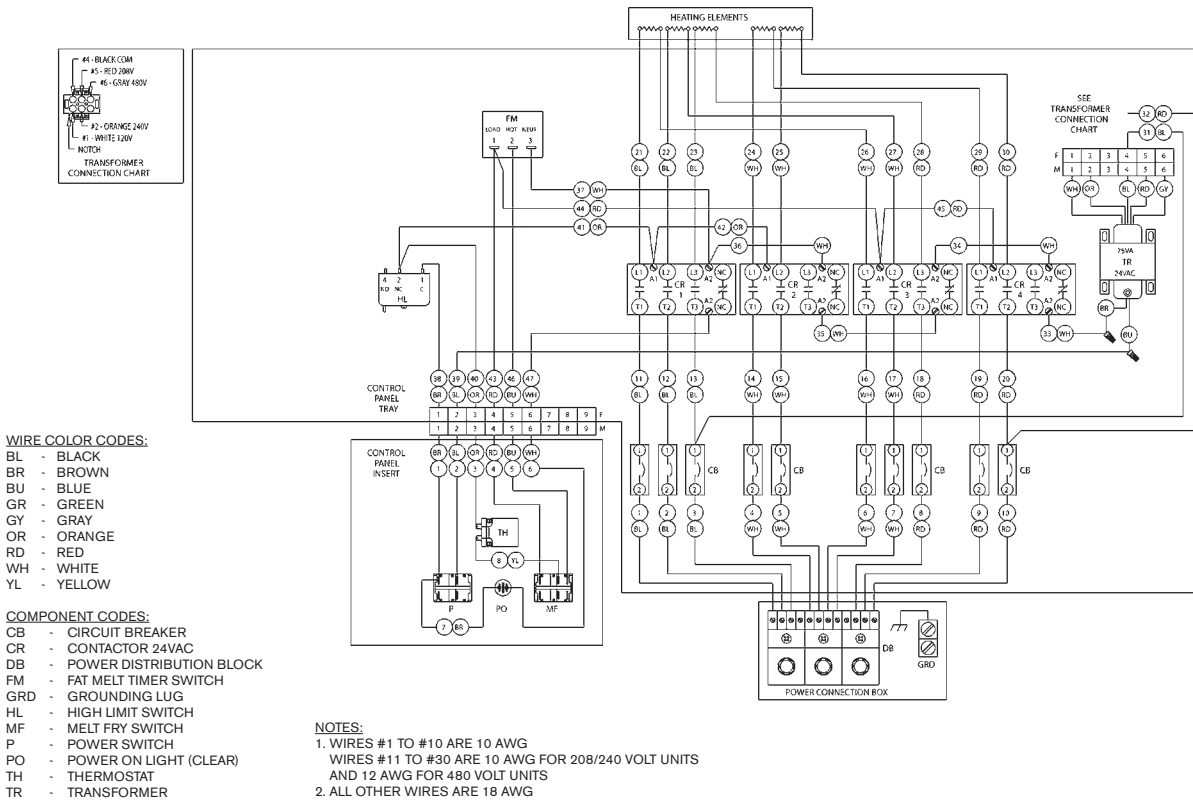

34x24 BB 2006 208-240V & 480V 3 PHASE with REAR DRAIN & SAFE & EASY® FILTER

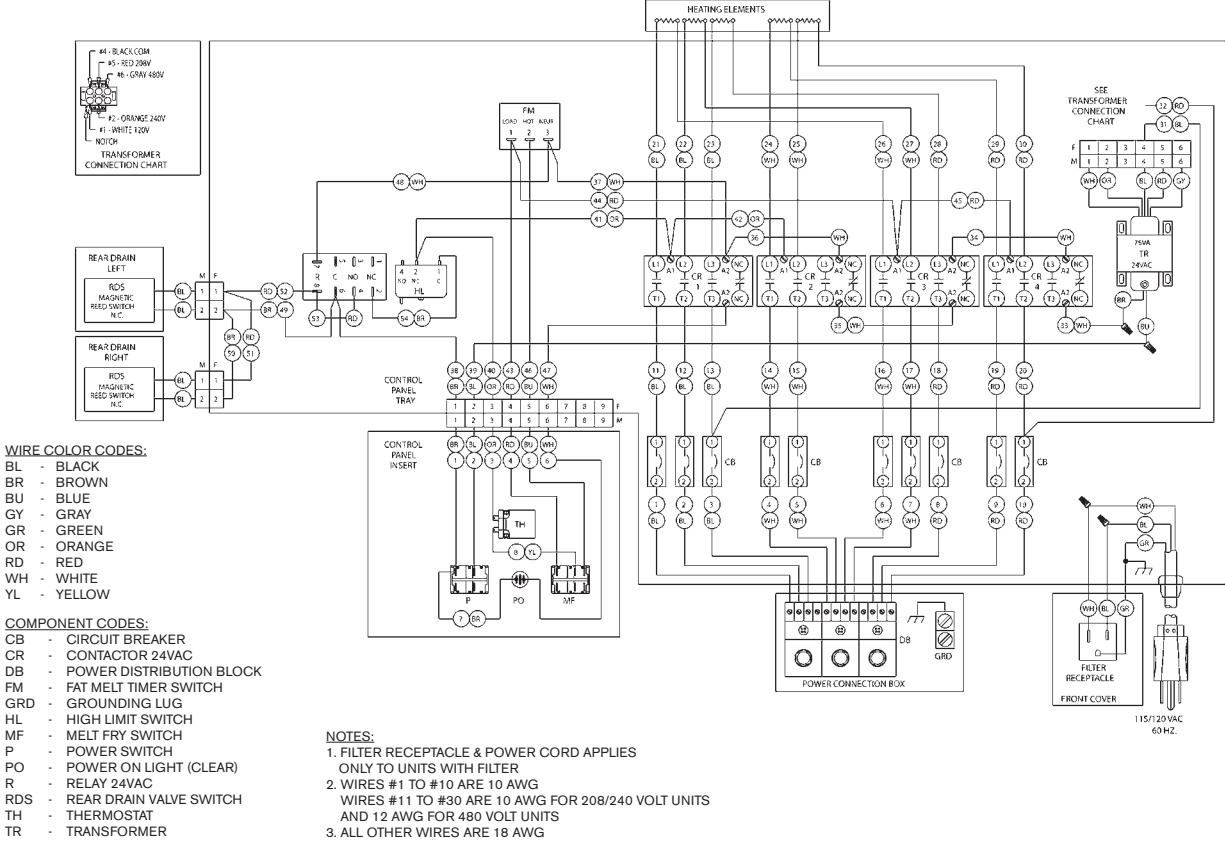

10x11 TS 2006 208-240V & 480V 3 PHASE FRONT DRAIN

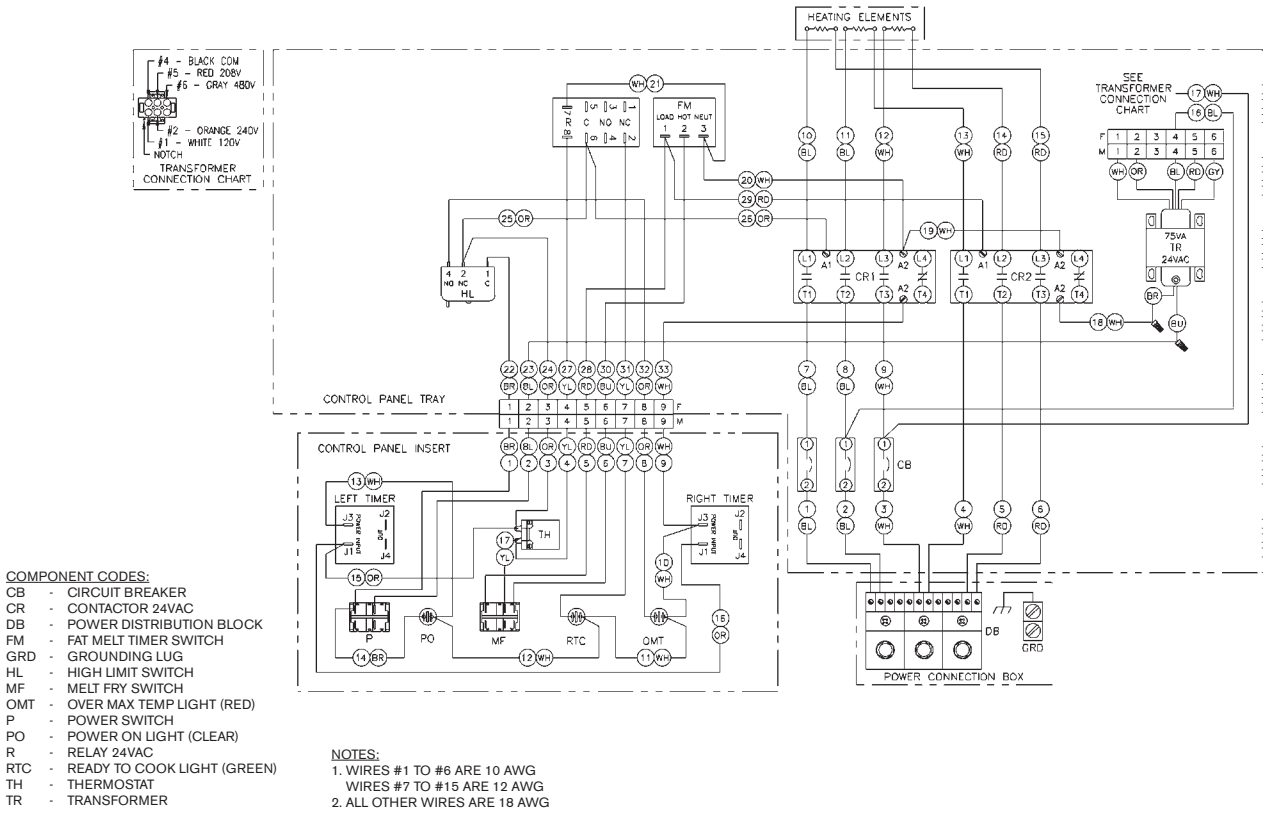

10x11 TS 2006 208-240V & 480V 3 PHASE with REAR DRAIN

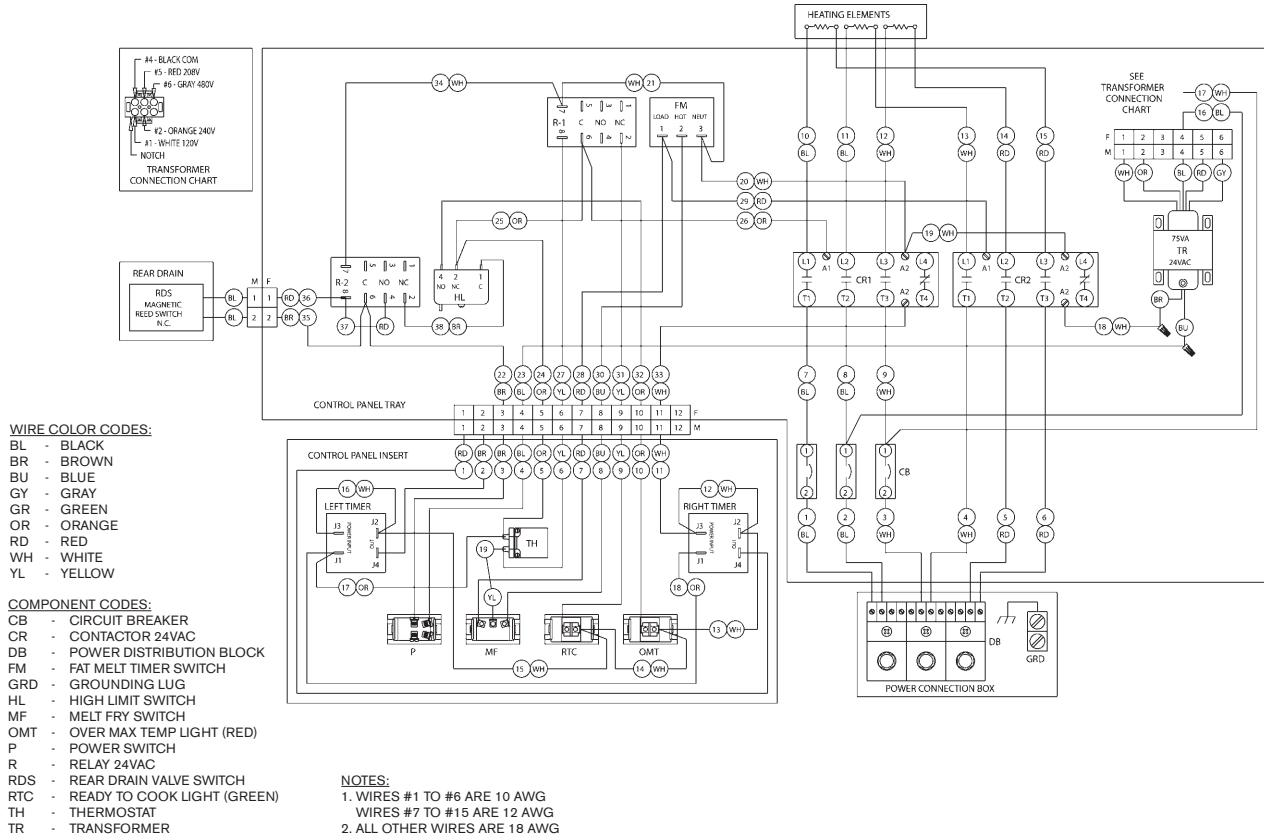

14 TS 2006 208-240V & 480V 3 PHASE FRONT DRAIN

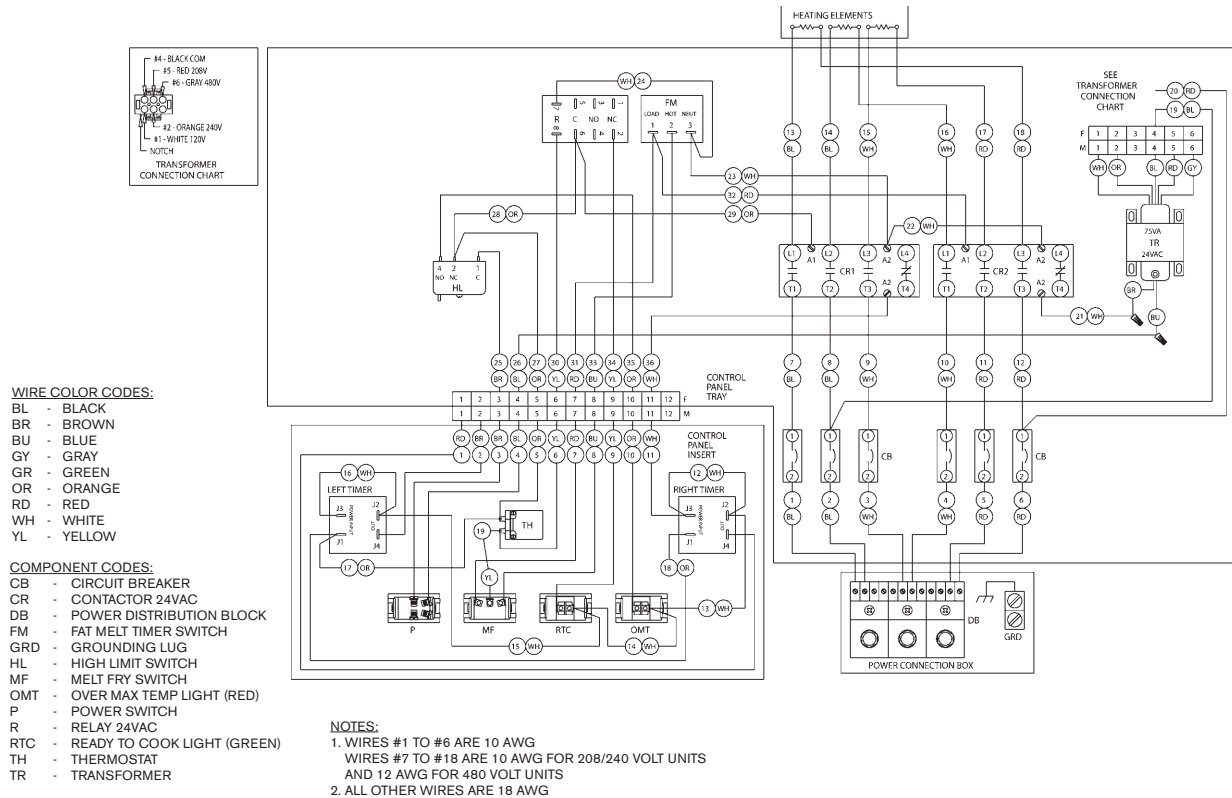

14 TS 2006 WITH BASKET-LIFT 208-240V & 480V 3 PHASE FRONT DRAIN

WIRE COLOR CODES:

- BL - BLACK
- BR - BROWN
- B/R - BLACK/RED
- BU - BLUE
- GY - GRAY
- GR - GREEN
- OR - ORANGE
- RD - RED
- WH - WHITE
- YL - YELLOW

COMPONENT CODES:

- CB - CIRCUIT BREAKER
- CR - CONTACTOR 24VAC
- DB - POWER DISTRIBUTION BLOCK
- FM - FAT MELT TIMER SWITCH
- GRD - GROUNDING LUG
- HL - HIGH LIMIT SWITCH
- MF - MELT FRY SWITCH
- OMT - OVER MAX TEMP LIGHT (RED)
- P - POWER SWITCH
- R - RELAY 24VAC
- RTC - READY TO COOK LIGHT (GREEN)
- TH - THERMOSTAT
- TR - TRANSFORMER

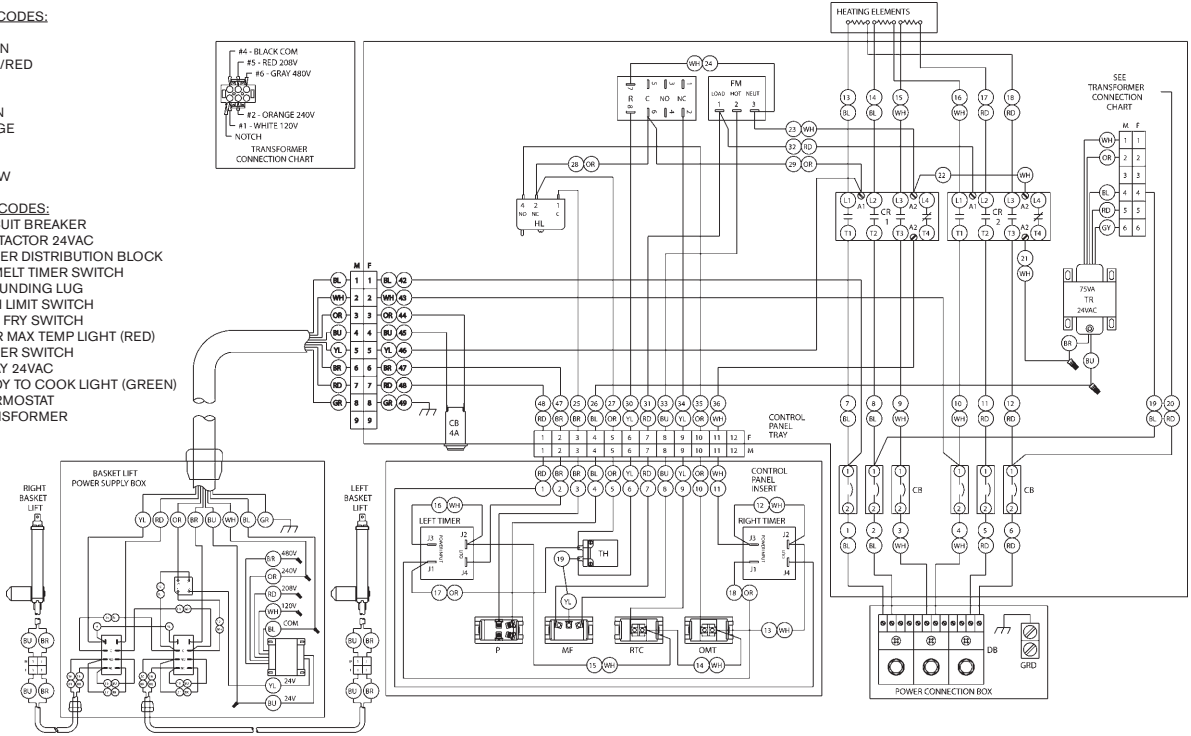

- NOTES:**
1. FILTER RECEPTACLE & POWER CORD APPLIES ONLY TO UNITS WITH FILTER
 2. WIRES #1 TO #6 ARE 10 AWG, WIRES #7 TO #18 ARE 10 AWG FOR 208/240 VOLT UNITS AND 12 AWG FOR 480 VOLT UNITS
 3. ALL OTHER WIRES ARE 18 AWG
 4. THIS DIAGRAM SHOWS 240 VAC SUPPLY VOLTAGE FOR THE PRIMARY SIDE OF THE TRANSFORMER FOR THE BASKET-LIFT POWER SUPPLY BOX

14 TS 2006 208-240V & 480V 3 PHASE with REAR DRAIN & SAFE & EASY® FILTER

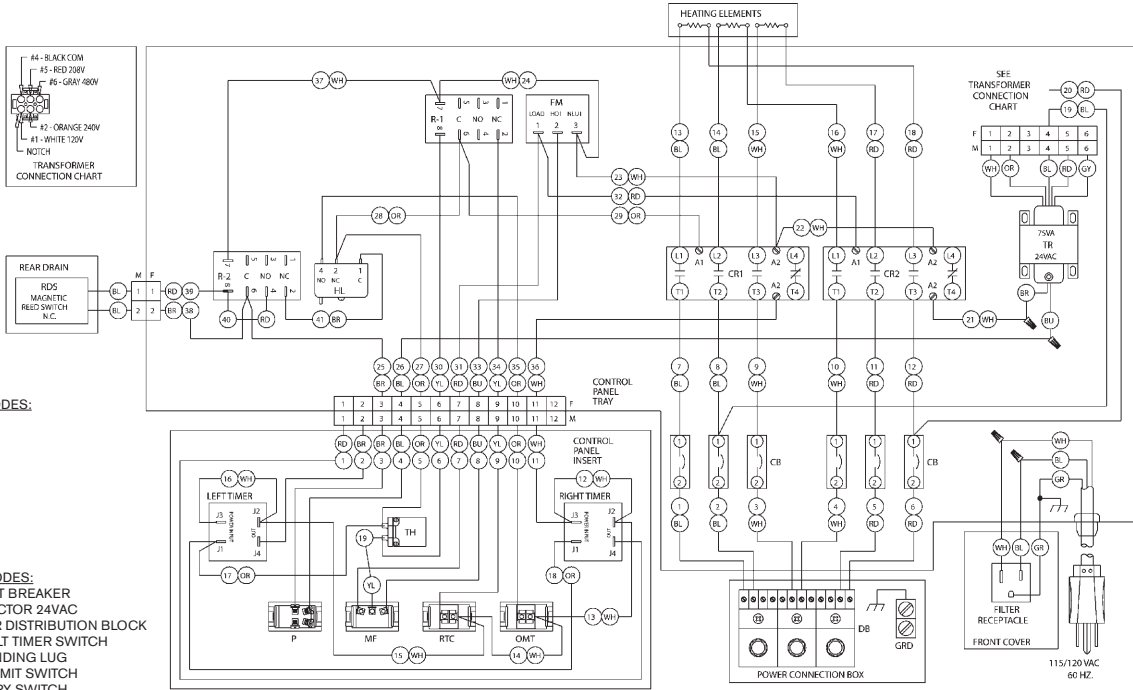

WIRE COLOR CODES:

- BL - BLACK
- BR - BROWN
- BU - BLUE
- GY - GRAY
- GR - GREEN
- OR - ORANGE
- RD - RED
- WH - WHITE
- YL - YELLOW

COMPONENT CODES:

- CB - CIRCUIT BREAKER
- CR - CONTACTOR 24VAC
- DB - POWER DISTRIBUTION BLOCK
- FM - FAT MELT TIMER SWITCH
- GRD - GROUNDING LUG
- HL - HIGH LIMIT SWITCH
- MF - MELT FRY SWITCH
- OMT - OVER MAX TEMP LIGHT (RED)
- P - POWER SWITCH
- R - RELAY 24VAC
- RDS - REAR DRAIN VALVE SWITCH
- RTC - READY TO COOK LIGHT (GREEN)
- TH - THERMOSTAT
- TR - TRANSFORMER

- NOTES:**
1. FILTER RECEPTACLE & POWER CORD APPLIES ONLY TO UNITS WITH FILTER
 2. WIRES #1 TO #6 ARE 10 AWG, WIRES #7 TO #18 ARE 10 AWG FOR 208/240 VOLT UNITS AND 12 AWG FOR 480 VOLT UNITS
 3. ALL OTHER WIRES ARE 18 AWG

14 TS 2006 with BASKET-LIFT 208-240V & 480V 3 PHASE with REAR DRAIN & SAFE & EASY® FILTER

WIRE COLOR CODES:

- BL - BLACK
- BR - BROWN
- B/R - BLACK/RED
- BU - BLUE
- GY - GRAY
- GR - GREEN
- OR - ORANGE
- RD - RED
- WH - WHITE
- YL - YELLOW

COMPONENT CODES:

- CB - CIRCUIT BREAKER
- CR - CONTACTOR 24VAC
- DB - POWER DISTRIBUTION BLOCK
- FM - FAT MELT TIMER SWITCH
- GRD - GROUNDING LUG
- HL - HIGH LIMIT SWITCH
- MF - MELT FRY SWITCH
- OMT - OVER MAX TEMP LIGHT (RED)
- P - POWER SWITCH
- R - RELAY 24VAC
- RDS - REAR DRAIN VALVE SWITCH
- RTC - READY TO COOK LIGHT (GREEN)
- TH - THERMOSTAT
- TR - TRANSFORMER

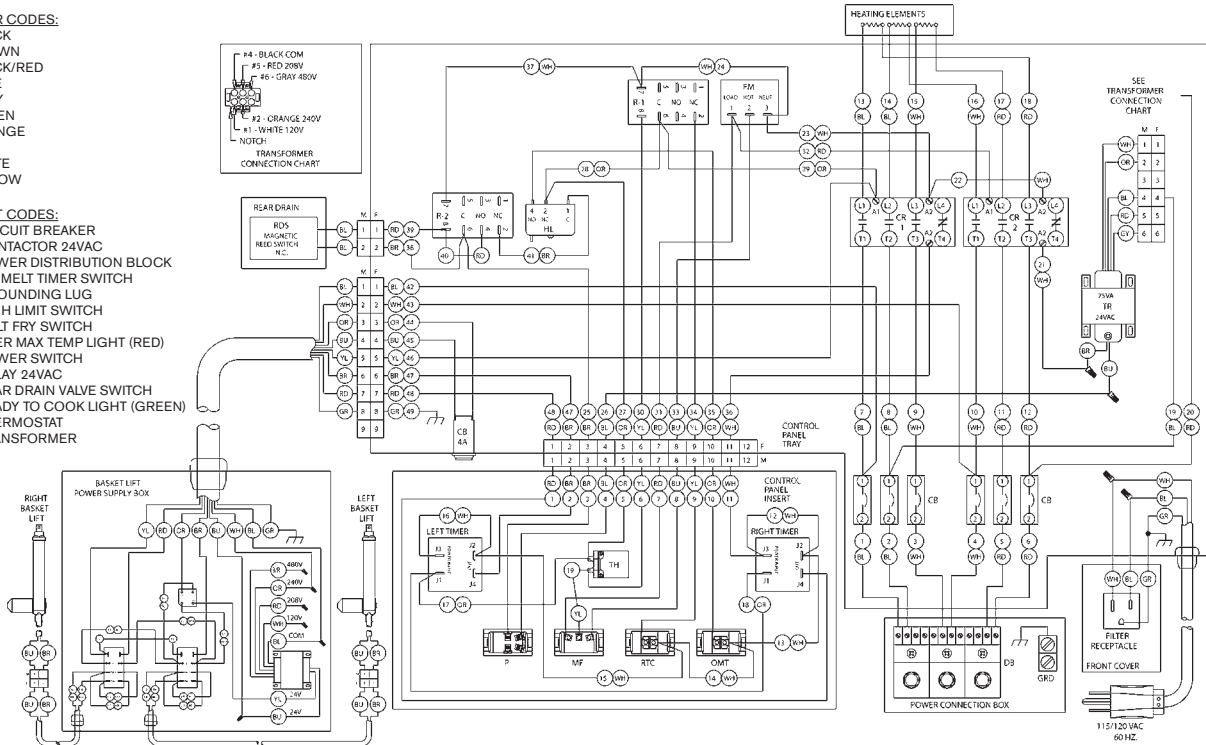

NOTES:

1. FILTER RECEPTACLE & POWER CORD APPLIES ONLY TO UNITS WITH FILTER
2. WIRES #1 TO #6 ARE 10 AWG, WIRES #7 TO #18 ARE 10 AWG FOR 208/240 VOLT UNITS AND 12 AWG FOR 480 VOLT UNITS
3. ALL OTHER WIRES ARE 18 AWG
4. THIS DIAGRAM SHOWS 240 VAC SUPPLY VOLTAGE FOR THE PRIMARY SIDE OF THE TRANSFORMER FOR THE BASKET-LIFT POWER SUPPLY BOX

18, 20 TS 2006 208-240V & 480V 3 PHASE FRONT DRAIN

WIRE COLOR CODES:

- BL - BLACK
- BR - BROWN
- BU - BLUE
- GY - GRAY
- GR - GREEN
- OR - ORANGE
- RD - RED
- WH - WHITE
- YL - YELLOW

COMPONENT CODES:

- CB - CIRCUIT BREAKER
- CR - CONTACTOR 24VAC
- DB - POWER DISTRIBUTION BLOCK
- FM - FAT MELT TIMER SWITCH
- GRD - GROUNDING LUG
- HL - HIGH LIMIT SWITCH
- MF - MELT FRY SWITCH
- OMT - OVER MAX TEMP LIGHT (RED)
- P - POWER SWITCH
- R - RELAY 24VAC
- RTC - READY TO COOK LIGHT (GREEN)
- TH - THERMOSTAT
- TR - TRANSFORMER

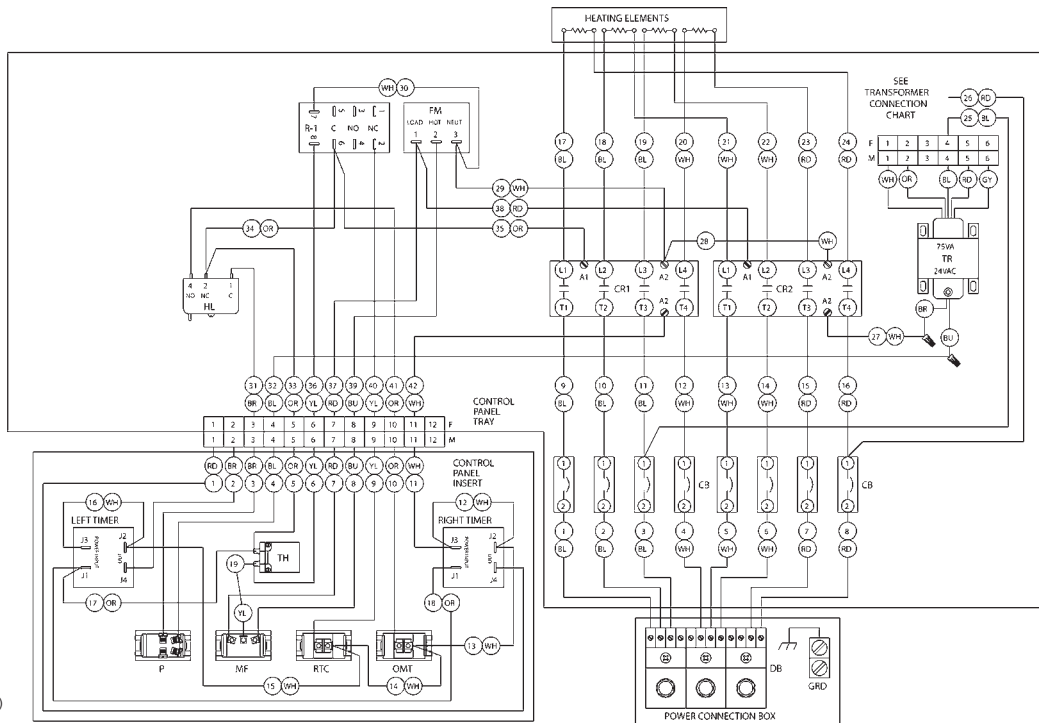

NOTES:

1. WIRES #1 TO #8 ARE 10 AWG
WIRES #9 TO #24 ARE 10 AWG FOR 208/240 VOLT UNITS
AND 12 AWG FOR 480 VOLT UNITS
2. ALL OTHER WIRES ARE 18 AWG

18, 20 TS 2006 208-240V & 480V 3 PHASE with BASKET-LIFT FRONT DRAIN

WIRE COLOR CODES:

- BL - BLACK
- BR - BROWN
- B/R - BLACK/RED
- BU - BLUE
- GY - GRAY
- GR - GREEN
- OR - ORANGE
- RD - RED
- WH - WHITE
- YL - YELLOW

COMPONENT CODES:

- CB - CIRCUIT BREAKER
- CR - CONTACTOR 24VAC
- DB - POWER DISTRIBUTION BLOCK
- FM - FAT MELT TIMER SWITCH
- GRD - GROUNDING LUG
- HL - HIGH LIMIT SWITCH
- MF - MELT FRY SWITCH
- OMT - OVER MAX TEMP LIGHT (RED)
- P - POWER SWITCH
- R - RELAY 24VAC
- RTC - READY TO COOK LIGHT (GREEN)
- TH - THERMOSTAT
- TR - TRANSFORMER

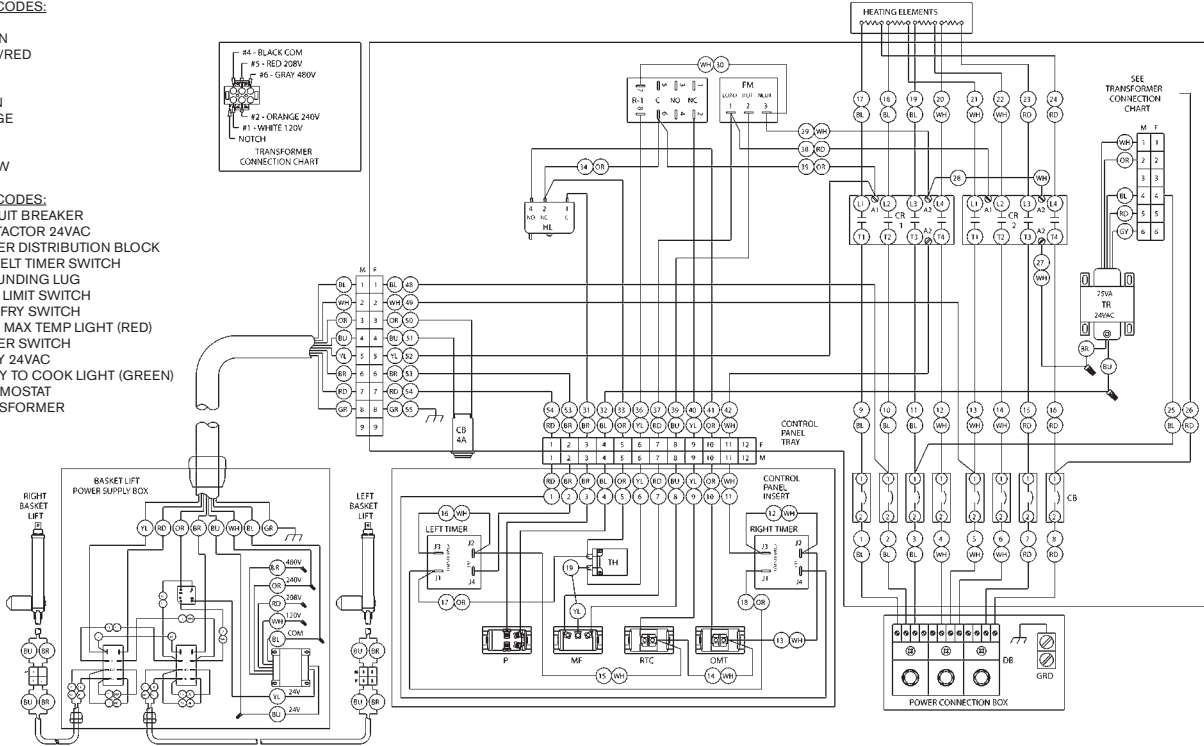

- NOTES:**
1. WIRES #1 TO #8 ARE 10 AWG, WIRES #9 TO #24 ARE 10 AWG FOR 208/240 VOLT UNITS AND 12 AWG FOR 480 VOLT UNITS
 2. ALL OTHER WIRES ARE 18 AWG
 3. THIS DIAGRAM SHOWS 240 VAC SUPPLY VOLTAGE FOR THE PRIMARY SIDE OF THE TRANSFORMER FOR THE BASKET-LIFT POWER SUPPLY BOX

18, 20 TS 2006 208-240V & 480V 3 PHASE with REAR DRAIN & SAFE & EASY® FILTER

WIRE COLOR CODES:

- BL - BLACK
- BR - BROWN
- BU - BLUE
- GY - GRAY
- GR - GREEN
- OR - ORANGE
- RD - RED
- WH - WHITE
- YL - YELLOW

COMPONENT CODES:

- CB - CIRCUIT BREAKER
- CR - CONTACTOR 24VAC
- DB - POWER DISTRIBUTION BLOCK
- FM - FAT MELT TIMER SWITCH
- GRD - GROUNDING LUG
- HL - HIGH LIMIT SWITCH
- MF - MELT FRY SWITCH
- OMT - OVER MAX TEMP LIGHT (RED)
- P - POWER SWITCH
- R - RELAY 24VAC
- RDS - REAR DRAIN VALVE SWITCH
- RTC - READY TO COOK LIGHT (GREEN)
- TH - THERMOSTAT
- TR - TRANSFORMER

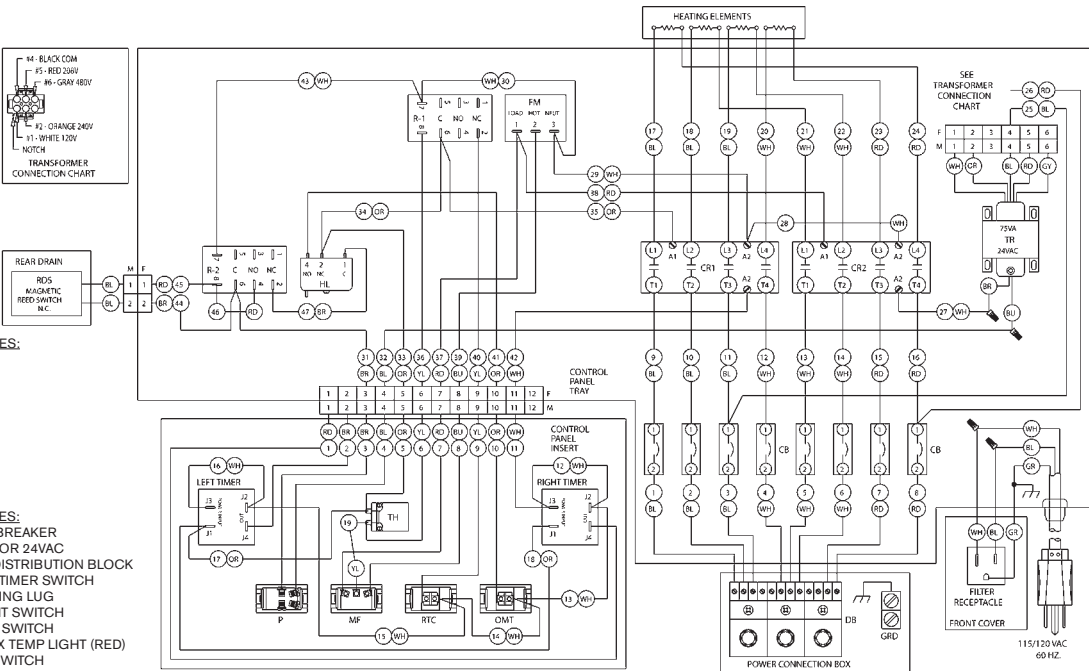

- NOTES:**
1. FILTER RECEPTACLE & POWER CORD APPLIES ONLY TO UNITS WITH FILTER
 2. WIRES #1 TO #8 ARE 10 AWG, WIRES #9 TO #24 ARE 10 AWG FOR 208/240 VOLT UNITS AND 12 AWG FOR 480 VOLT UNITS
 3. ALL OTHER WIRES ARE 18 AWG

18, 20 TS 2006 with BASKET-LIFT 208-240V & 480V 3 PHASE with REAR DRAIN & SAFE & EASY® FILTER

WIRE COLOR CODES:

- BL - BLACK
- BR - BROWN
- B/R - BLACK/RED
- BU - BLUE
- GY - GRAY
- GR - GREEN
- OR - ORANGE
- RD - RED
- WH - WHITE
- YL - YELLOW

COMPONENT CODES:

- CB - CIRCUIT BREAKER
- CR - CONTACTOR 24VAC
- DB - POWER DISTRIBUTION BLOCK
- FM - FAT MELT TIMER SWITCH
- GRD - GROUNDING LUG
- HL - HIGH LIMIT SWITCH
- MF - MELT FRY SWITCH
- OMT - OVER MAX TEMP LIGHT (RED)
- P - POWER SWITCH
- R - RELAY 24VAC
- RDS - REAR DRAIN VALVE SWITCH
- RTC - READY TO COOK LIGHT (GREEN)
- TH - THERMOSTAT
- TR - TRANSFORMER

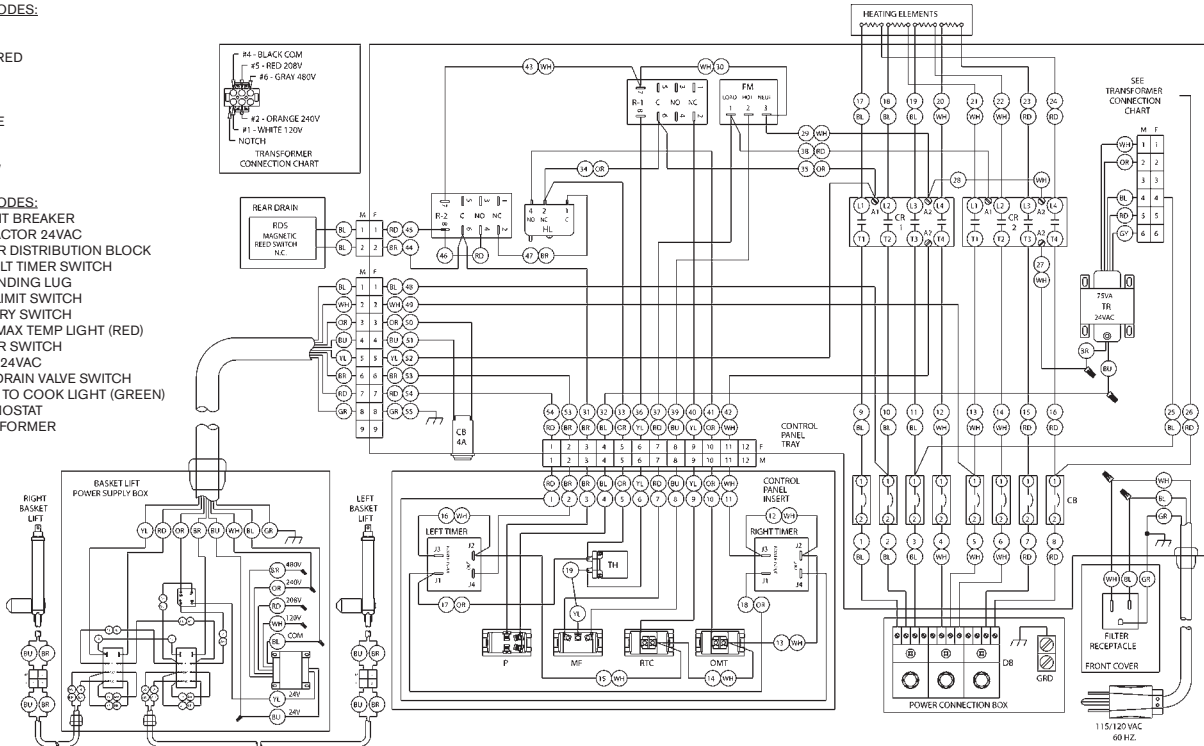

NOTES:

1. FILTER RECEPTACLE & POWER CORD APPLIES ONLY TO UNITS WITH FILTER
2. WIRES #1 TO #8 ARE 10 AWG, WIRES #9 TO #24 ARE 10 AWG FOR 208/240 VOLT UNITS AND 12 AWG FOR 480 VOLT UNITS
3. ALL OTHER WIRES ARE 18 AWG
4. THIS DIAGRAM SHOWS 240 VAC SUPPLY VOLTAGE FOR THE PRIMARY SIDE OF THE TRANSFORMER FOR THE BASKET-LIFT POWER SUPPLY BOX

24 TS 2006 208-240V & 480V 3 PHASE FRONT DRAIN

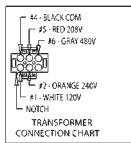

WIRE COLOR CODES:

- BL - BLACK
- BR - BROWN
- BU - BLUE
- GY - GRAY
- GR - GREEN
- OR - ORANGE
- RD - RED
- WH - WHITE
- YL - YELLOW

COMPONENT CODES:

- CB - CIRCUIT BREAKER
- CR - CONTACTOR 24VAC
- DB - POWER DISTRIBUTION BLOCK
- FM - FAT MELT TIMER SWITCH
- GRD - GROUNDING LUG
- HL - HIGH LIMIT SWITCH
- MF - MELT FRY SWITCH
- OMT - OVER MAX TEMP LIGHT (RED)
- P - POWER SWITCH
- R - RELAY 24VAC
- RTC - READY TO COOK LIGHT (GREEN)
- TH - THERMOSTAT
- TR - TRANSFORMER

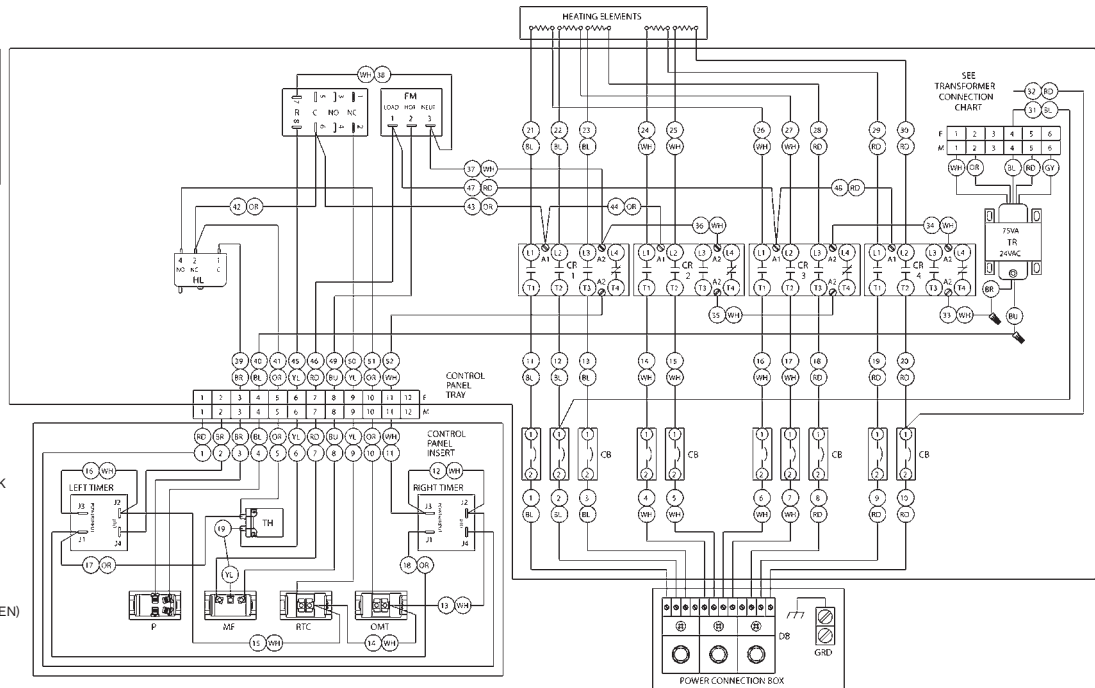

NOTES:

1. WIRES #1 TO #10 ARE 10 AWG, WIRES #11 TO #30 ARE 10 AWG FOR 208/240 VOLT UNITS AND 12 AWG FOR 480 VOLT UNITS
2. ALL OTHER WIRES ARE 18 AWG

24 TS 2006 208-240V & 480V 3 PHASE with REAR DRAIN and SAFE & EASY® FILTER

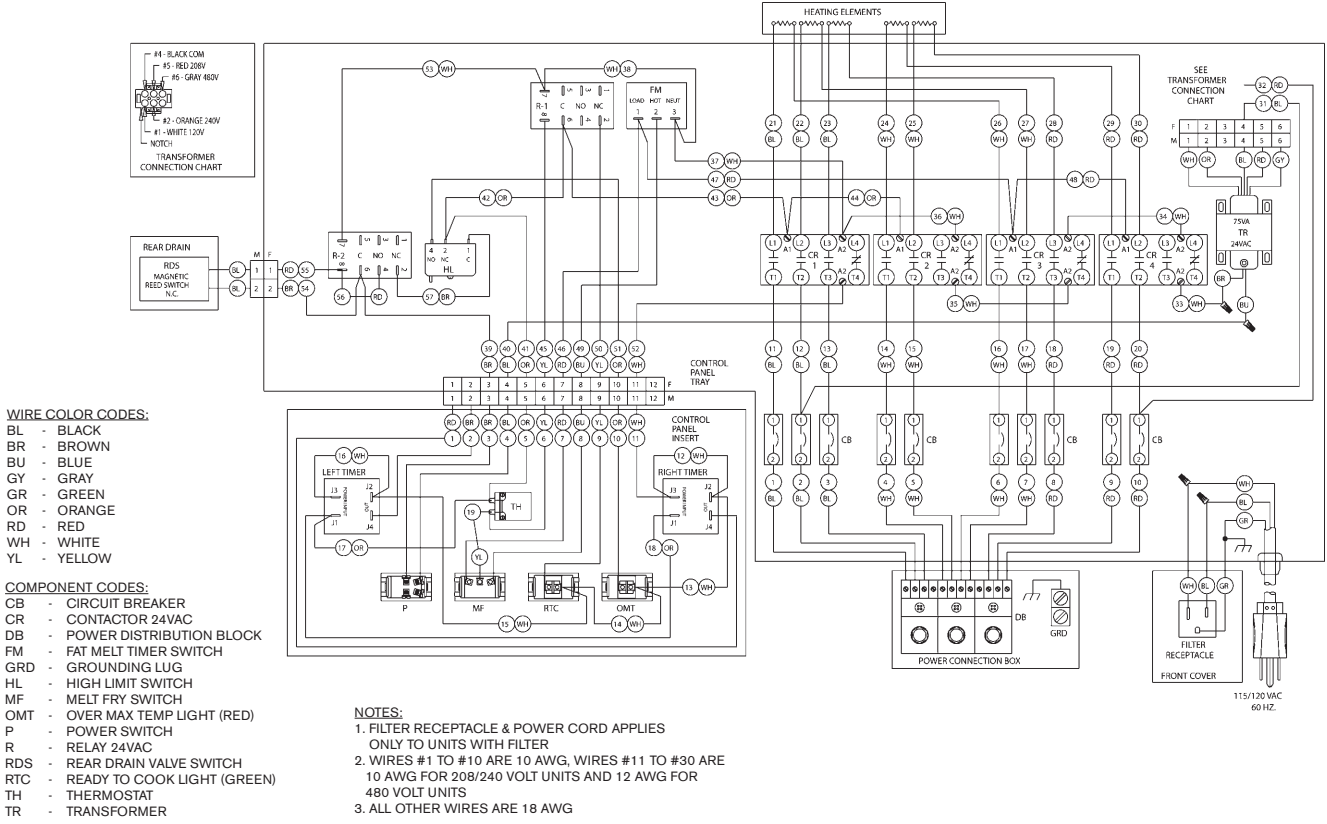

34x24 TS 2006 208-240V & 480V 3 PHASE FRONT DRAIN

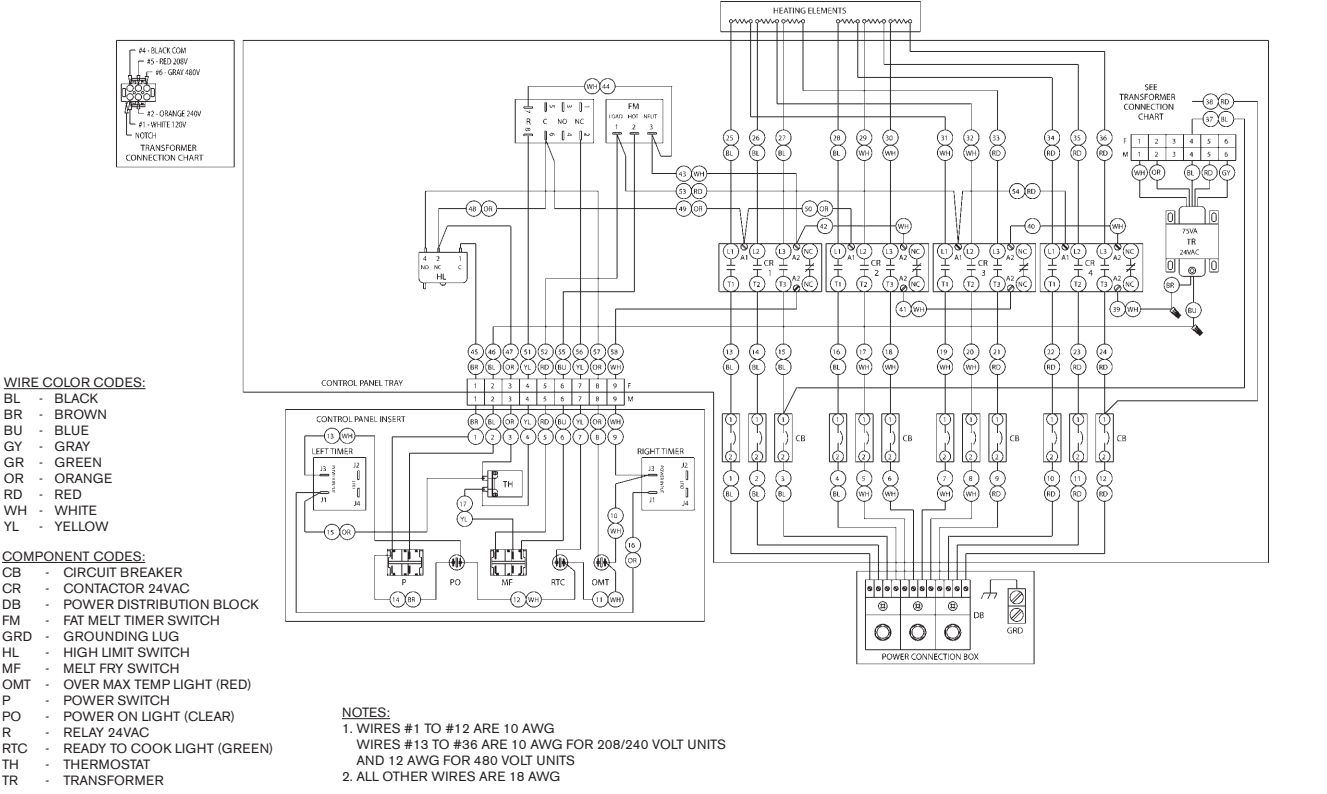

34x24 TS 2006 208-240V & 480V 3 PHASE WITH REAR DRAIN & SAFE & EASY® FILTER

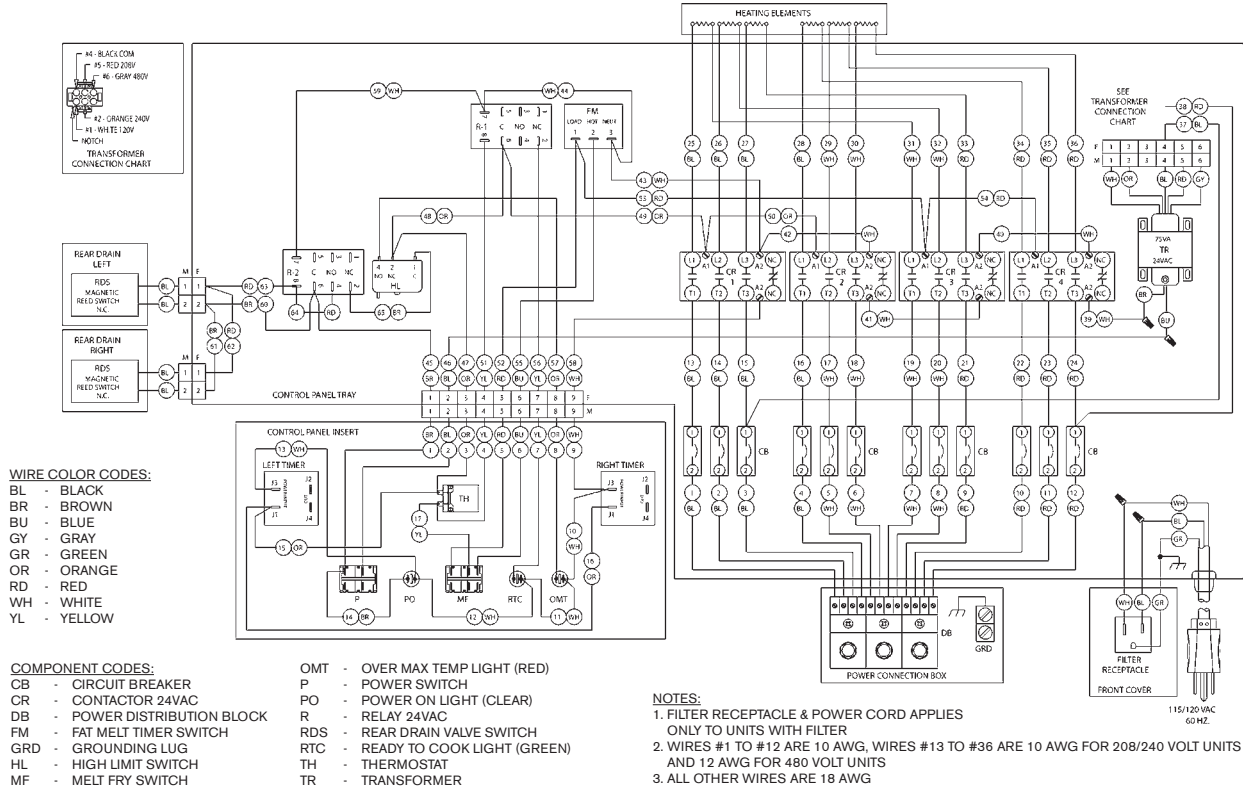

14 CPU 2007 208-240V & 480V 3 PHASE WITH REAR DRAIN & SAFE & EASY® FILTER

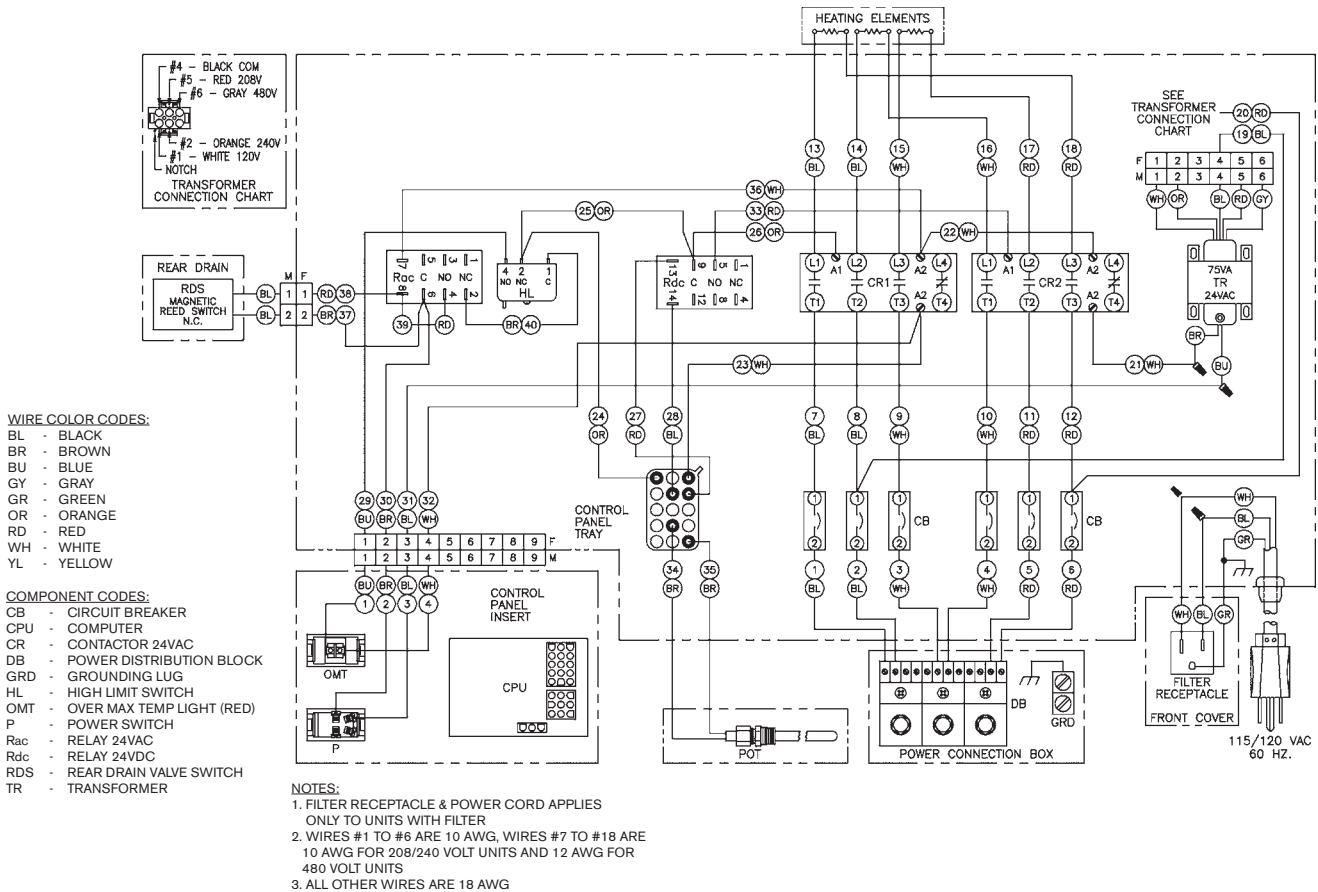

34x24 CPU 2007 208-240V & 480V 3 PHASE with REAR DRAIN & SAFE & EASY® FILTER

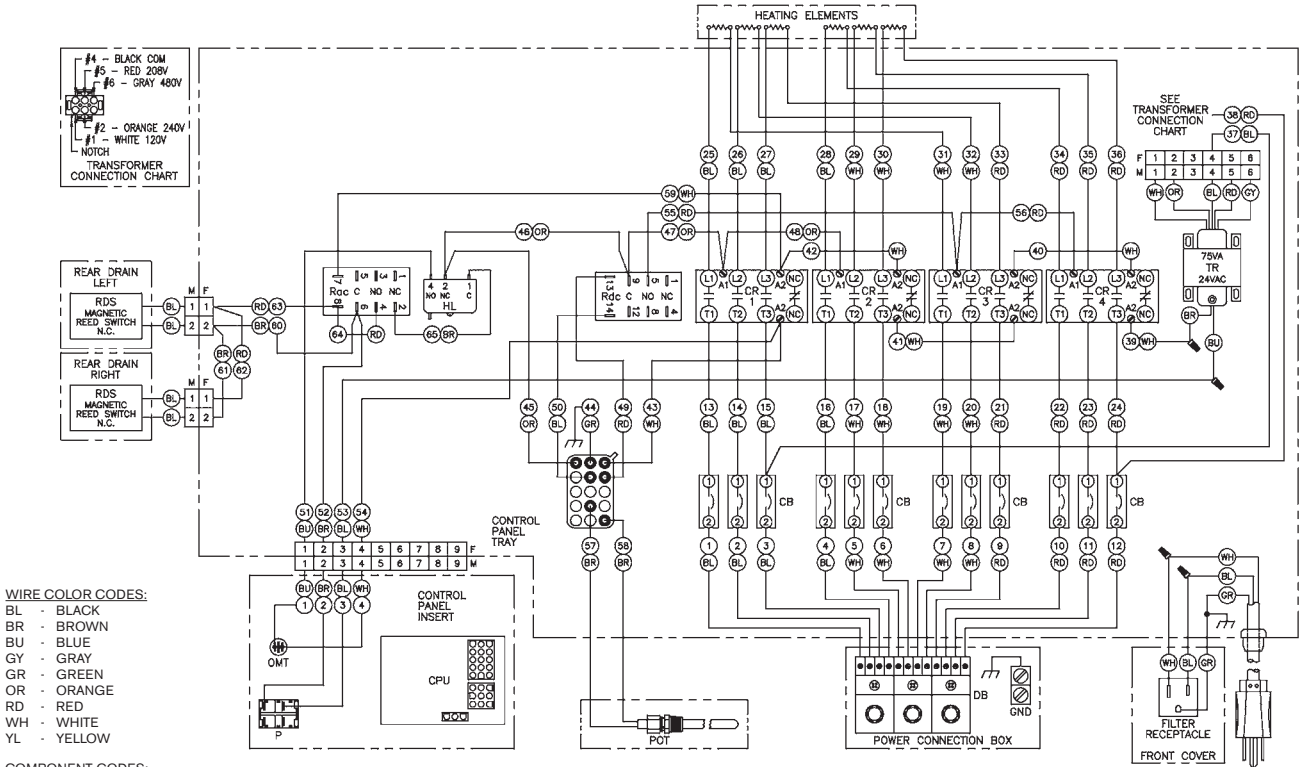

WIRE COLOR CODES:
 BL - BLACK
 BR - BROWN
 BU - BLUE
 GR - GREEN
 OR - ORANGE
 RD - RED
 WH - WHITE
 YL - YELLOW

COMPONENT CODES:
 CB - CIRCUIT BREAKER
 CPU - COMPUTER
 CR - CONTACTOR 24VAC
 DB - POWER DISTRIBUTION BLOCK
 GRD - GROUNDING LUG
 HL - HIGH LIMIT SWITCH
 OMT - OVER MAX TEMP LIGHT (RED)
 P - POWER SWITCH
 Rac - RELAY 24VAC
 Rdc - RELAY 24VDC
 RDS - REAR DRAIN VALVE SWITCH
 TR - TRANSFORMER

- NOTES:**
1. FILTER RECEPTACLE & POWER CORD APPLIES ONLY TO UNITS WITH FILTER
 2. WIRES #1 TO #12 ARE 10 AWG, WIRES #13 TO #36 ARE 10 AWG FOR 208/240 VOLT UNITS AND 12 AWG FOR 480 VOLT UNITS
 3. ALL OTHER WIRES ARE 18 AWG

115/120 VAC
60 HZ.

■ KEATING FRYER SPECIFICATIONS

BB MODELS:

10x11 BB

VOLTS	kW	AMPS PER LINE - THREE PHASE			AMPS SINGLE PHASE
		L1	L2	L3	
208	6.7	19	19	19	32
220	7.5	20	20	20	34
240	8.9	21	21	21	37
480	8.9	11	11	11	19

- 3 ELEMENTS (2500W EACH)

14 BB

VOLTS	kW	AMPS PER LINE - THREE PHASE			AMPS SINGLE PHASE
		L1	L2	L3	
208	11.7	33	33	33	56
220	13.1	34	34	34	59
240	15.5	37	37	37	65
480	15.5	19	19	19	32

- 3 ELEMENTS (4350W EACH)

18/20 BB

VOLTS	kW	AMPS PER LINE - THREE PHASE			AMPS SINGLE PHASE
		L1	L2	L3	
208	16.1	45	45	45	77
220	18.0	47	47	47	82
240	21.4	52	52	52	89
480	21.4	26	26	26	45

- 3 ELEMENTS (6000W EACH)

24 BB

VOLTS	kW	AMPS PER LINE - THREE PHASE			AMPS SINGLE PHASE
		L1	L2	L3	
208	21.5	68	68	45	103
220	24.0	72	72	47	109
240	28.6	79	79	52	119
480	28.6	39	39	26	60

- 4 ELEMENTS (6000W EACH)

34x24 BB

VOLTS	kW	AMPS PER LINE - THREE PHASE			AMPS SINGLE PHASE
		L1	L2	L3	
208	28.6	68	89	68	129
220	30.0	72	95	72	136
240	35.7	79	103	79	149
480	35.7	39	52	39	74

- 5 ELEMENTS (6000W EACH)

* RATINGS ARE THE SAME FOR FLOOR MODELS AND COUNTER MODELS

TS MODELS:

10x11 TS

VOLTS	kW	AMPS PER LINE - THREE PHASE			AMPS SINGLE PHASE
		L1	L2	L3	
208	10.2	28	28	28	49
220	11.4	30	30	30	52
240	13.6	33	33	33	57
480	13.6	16	16	16	28

- 3 ELEMENTS (3800W EACH)

14 TS

VOLTS	kW	AMPS PER LINE - THREE PHASE			AMPS SINGLE PHASE
		L1	L2	L3	
208	17.4	48	48	48	84
220	19.5	51	51	51	89
240	23.2	56	56	56	97
480	23.2	28	28	28	48

- 3 ELEMENTS (6500W EACH)

18/20 TS

VOLTS	kW	AMPS PER LINE - THREE PHASE			AMPS SINGLE PHASE
		L1	L2	L3	
208	21.5	68	68	45	103
220	24.0	72	72	47	109
240	28.6	79	79	52	119
480	28.6	39	39	26	60

- 4 ELEMENTS (6000W EACH)

24 TS

VOLTS	kW	AMPS PER LINE - THREE PHASE			AMPS SINGLE PHASE
		L1	L2	L3	
208	26.8	68	89	68	129
220	30.0	72	95	72	136
240	35.7	79	103	79	149
480	35.7	39	52	39	74

- 5 ELEMENTS (6000W EACH)

34x24 TS

VOLTS	kW	AMPS PER LINE - THREE PHASE			AMPS SINGLE PHASE
		L1	L2	L3	
208	32.2	89	89	89	155
220	36.0	95	95	95	164
240	42.8	103	103	103	179
480	42.8	52	52	52	89

- 6 ELEMENTS (6000W EACH)



WARRANTY

LIMITED WARRANTY

Keating of Chicago, Inc. ("Keating") warrants to the original purchaser, ("Customer"), all new Keating Fryers, Filter Systems, Griddles, Keep Krisp[®], Custom Pasta Systems, Top-Side[™] Cookers, Computer Timers, Fryer & Pasta Vessels and Keating replacement parts ("products") installed after June 1, 1994 to be free of defects in material or workmanship, subject to the following terms and conditions.

LENGTH OF WARRANTY

All products other than Fryer & Pasta Vessels and replacement parts shall be warranted for a period of one year from the date of original equipment installation. Keating replacement parts are warranted for a period of ninety days from the date of installation. Fryer & Pasta Vessels are warranted as described below.

FRYER & PASTA VESSEL WARRANTY

Fryers purchased after June 1, 1994 carry a prorated vessel warranty on defects in materials or workmanship to the Customer based on the following scale:

Time from Installation Date	Fryer Vessel Warranty Credit
13-60 months	100%
61-72 months	80%
73-84 months	60%
85-96 months	40%
97-108 months	20%
109-120 months	10%

The credit for the defective fryer & pasta vessel shall be applied against the cost of the replacement vessel, utilizing Keating's then current price, upon return of the vessel to Keating only during the first 60 months, subject to the limitations described below.

LIMITATIONS OF LIABILITY

In the event of warranty claim or otherwise, the sole obligation of Keating shall be the repair and / or replacement at the option of Keating of the product or component part thereof. Such repair or replacement shall be at the expense of Keating except that the Customer shall pay the following expenses: all freight and labor expense for Keating replacement parts; for all other products, mileage exceeding 50 miles or travel more than one hour, labor costs of more than one person, overtime rates, truck charges, difference between ground and other mode of transportation, and holiday charges. Any repair or replacement under this Limited Warranty does not constitute an extension of the original warranty for any period for the product or for any component or part thereof. Parts to be replaced under this Limited Warranty will be repaired at the option of Keating with new or functionally operative parts. Keep Krisps and Computer Timers must be returned to Keating for warranty repair or replacement. Field repairs of those items are not authorized.

THE LIABILITY OF KEATING ON ANY CLAIM OF ANY KIND, INCLUDING CLAIMS BASED ON WARRANTY, EXPRESSED OR IMPLIED, CONTRACT, NEGLIGENCE, STRICT LIABILITY OR ANY OTHER THEORIES SHALL BE SOLELY AND EXCLUSIVELY THE REPAIR OR REPLACEMENT OF THE PRODUCT AS STATED HEREIN, AND SUCH LIABILITY SHALL NOT INCLUDE, AND CUSTOMER SPECIFICALLY RENOUNCES ANY RIGHTS TO RECOVER, SPECIAL, INCIDENTAL, CONSEQUENTIAL OR OTHER INJURIES TO PERSONS OR DAMAGE TO PROPERTY, LOSS OF PROFITS OR ANTICIPATED PROFITS, OR LOSS OF USE OF THE PRODUCT.

If any oral statements have been made regarding the Keating products, such statements do not constitute warranties and are not part of the contract sale. This Limited Warranty constitutes the complete, final and exclusive statement with regard to warranties.

THIS LIMITED WARRANTY IS EXCLUSIVE AND IS IN LIEU OF ALL OTHER WARRANTIES WHETHER WRITTEN, ORAL, STATUTORY OR IMPLIED, INCLUDING BUT NOT LIMITED TO ANY WARRANTY OF MERCHANTABILITY OR FITNESS FOR PARTICULAR PURPOSE OR WARRANTY AGAINST LATENT DEFECTS.

EXCLUSIONS

The warranties provided by Keating of Chicago, Inc. do not apply in the following instances:

1. Defects arising out of or resulting from improper installation or maintenance, abuse, misuse, modification or alteration by unauthorized service personnel, or any other condition not attributable to a defect in material or workmanship. Proper installation and maintenance are the responsibility of the installer and Customer, respectively. Proper installation and maintenance procedures are prescribed by the Keating Service Manual.
2. In the event that the product was damaged after leaving the factory due to flood, fire, other acts of God or accident, damaged during shipment should be reported to the carrier and is not the responsibility of Keating.
3. In the event the serial number or rating plate has been removed from the product or altered.
4. On parts which would normally be worn or replaced under normal conditions, including but not limited to electric bulbs, fuses, interior and exterior finishes, gaskets and radiants.
5. With regard to adjustments and calibrations such as leveling, tightening of fasteners or plumbing connections, improper gas pressure or improper electrical supply, the checking of and changes in adjustment and calibrations are the responsibility of the installer. Proper installation procedures are prescribed by the Keating Service Manual.
6. In the event of unauthorized repairs or alterations to the Keating product.
7. With the use of sodium chloride in pasta vessels or harsh chemicals in fryer or pasta vessels.
8. Installation in Household.

OTHER TERMS AND CONDITIONS

The Customer must provide proof of purchase from Keating.

This Limited Warranty is valid in the 50 United States, its territories, and Canada, and is void elsewhere. Keating products are sold for commercial use only. If any Keating product is sold as a component of another product or used as a consumer product, such Keating product is sold As Is without any warranty.

If any provision of this Limited Warranty is held to be unenforceable under the law of any jurisdiction, such provision shall be inapplicable in such jurisdiction, and the remainder of the warranty shall remain unaffected. Further in such event, the maximum exclusion or limitation allowable under applicable law shall be deemed substituted for the unenforceable provision.

This Limited Warranty shall be governed by and construed in accordance with the laws of the State of Illinois.

TO SECURE WARRANTY SERVICE

All repair services under this Limited Warranty must be authorized by Keating or performed at Keating. Authorization may be obtained by calling 1-800-KEATING within the Continental United States, Alaska, Hawaii, Puerto Rico and Canada during normal business hours (8 a.m. through 5 p.m. Central Time, Monday through Friday). When calling, please have the following information available: (1) name, address and telephone number of the Customer; (2) location of product, if different; (3) name, model number and serial number of the product; (4) installation date; and (5) description of defect. Keating will then issue a service authorization work order number to one of its approved independent servicing organizations, or request the product or part be shipped to Keating for repair or replacement, as appropriate. Any defective part subject to a claim under this Limited Warranty must be shipped freight prepaid to Keating for testing and examination. Keating's decision as to the cause and nature of any defect under this Limited Warranty shall be final.

■ **SERVICE INFORMATION:**

If you have a service related question call **1-800-KEATING**.
Please state the nature of the call; it will ensure speaking with the appropriate person.

Have your serial and model number available when ordering parts.

As continuous product improvement occurs, specifications may be changed without notice.

.....
KEATING LIMITED WARRANTY CARD

PLEASE COMPLETE AND MAIL AT ONCE--WARRANTY IS NOT IN EFFECT UNTIL CARD IS RETURNED, OR COMPLETE THE WARRANTY CARD ON OUR WEBSITE FOR YOUR CONVENIENCE.

COMPANY: _____

ADDRESS: _____

CITY: _____ STATE: _____ ZIP CODE: _____

DEALER NAME: _____

DATE OF PURCHASE: _____ INVOICE #: _____

SERIAL #: _____ MODEL: _____

FRYER GRIDDLE CUSTOM PASTA
 FILTER SYSTEM TOP-SIDE COOKER HOTPLATE

I HAVE READ THE INSTALLATION AND OPERATING INSTRUCTIONS.

SIGNED: _____ DATE: _____



KEATING OF CHICAGO, INC.
8901 West 50th Street
McCook, IL 60525-6001

1-800-KEATING
PHONE: 708-246-3000
FAX: 708-246-3100

Serving Those Who Serve the Very Best®