



TOP-SIDE™ COOKER SERIES PRE-2005

MANUAL

■ IMPORTANT:

THIS MANUAL PROVIDES SPECIFIC OPERATING INSTRUCTIONS FOR YOUR MODEL. USE THE TOP-SIDE™ COOKER ONLY AS INSTRUCTED IN THIS MANUAL.

KEEP A COPY OF YOUR BILL OF SALE.

The date on the bill establishes the warranty period should service be required. If service is performed, it is in your interest to obtain and keep all receipts.

KEEP THIS MANUAL FOR TRAINING NEW PERSONNEL.

Record the Serial number and Model number of this Keating Top Side™ Cooker in the spaces provided. **Keep these numbers for future reference.**

SERIAL NUMBER

MODEL NUMBER

The Keating Top-Side™ Cooker is not intended for household use.

As continuous product improvement occurs, specifications may be changed without notice.

1-800-KEATING | keatingofchicago.com

NOTE:

PURCHASER SHOULD POST IN A PROMINENT LOCATION.

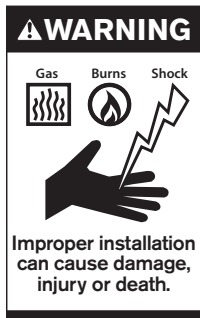

⚠ WARNING

Improper installation, adjustment, alteration, service or maintenance can cause property damage, injury or death. Read the installation, operating and maintenance instructions thoroughly before installing or servicing this equipment.



FOR YOUR SAFETY:

Do not store or use gasoline or other flammable vapors or liquids in the vicinity of this or any other appliance.



⚠ WARNING

Before obtaining access to terminals, all supply circuits must be disconnected.



■ TABLE OF CONTENTS

| | | | |
|---|----------|--|-----------|
| Important Safety Instructions | i | MAINTENANCE | 5 |
| INTRODUCTION | 1 | Warranty Repairs | 5 |
| Standard Features | 1 | Preventative Maintenance | 5 |
| Safety Precautions | 2 | Installing a Cooking Sheet | 5 |
| INSTALLATION | 2 | Handling a Cooking Sheet | 6 |
| Damage During Shipment | 2 | Removal of Cooking Head | 6 |
| FIRST STEPS | 2 | SERVICE DIAGNOSIS | 6 |
| Electrical Connection | 2 | Troubleshooting Chart | 7 |
| Wire Size | 2 | Thermostat Replacement Instructions | 8 |
| OPERATING | 3 | ORDERING PARTS | 10 |
| Conditioning the Miraclean® Plate | 3 | Warning and Operating Plates | 10 |
| Cooking | 3 | Top-Side™ Cooking Head (Exploded View) | 10 |
| Cooking Height Adjustment | 4 | Cooking Head Parts List | 11 |
| Shutdown | 4 | Control Panel Assembly | 12 |
| Cleaning Procedures | 4 | WIRING DIAGRAMS | 13 |
| Cooking Sheet | 4 | | |
| Cooking Sheet Clips | 4 | | |
| Cooking Head | 4 | | |

■ INTRODUCTION

Instructions in this manual should be read thoroughly before attempting to operate this Keating Top-Side™ Cooker. All installation and service on Keating equipment must be performed by qualified, certified, licensed and/or authorized installation or service personnel.

Operating information for Keating equipment has been prepared for use by qualified and/or authorized personnel.

Keating equipment is made in the USA and has American sizes of hardware. All metric conversions are approximate.

GENERAL

Keating Top-Side™ Cookers are designed to give maximum production efficiency, delivering high quality food products. The following design features are incorporated into Keating Top-Side™ Cookers.

STANDARD FEATURES

- Miraclean® cooking surface
- Stainless steel control panel
- Stainless steel head cover
- Electronic Thermostat
- Adjustable cooking height, from 1/8" to 1-1/2" (3mm to 38mm)
- Locking mechanism for Micro-Level

STANDARD ACCESSORIES

- Proprietary polymer cooking sheet (1)

NOTE:

Keating of Chicago, Inc. (manufacturer) reserves the right to change specifications at any time.

COOKING HEAD SPECIFICATIONS

Each Top-Side™ cooking head is designed to be connected to a 208, 220 or 240 volt single phase line.

| HEIGHT | WIDTH | DEPTH | WATTS | AMPS | kW |
|------------------|--------------------|----------------|---------------|-------------|-------------|
| 3 5/8" (92mm) | 10 1/2" (267mm) | 20" (508mm) | 4000 @220V | 18 @220V | 4.0 @220 |

STANDARD TOP-SIDE™ COOKERS

- Sizes: 1 to 6 heads.
- Mounting: Can be mounted to any standard Miraclean® gas or electric 30" (762mm) deep griddle (24" deep plate / 610mm) up to 72" wide (up to 6 heads maximum). Front trough only griddles are preferred for multiple heads.
- Cooking Surface: 10-1/2" (267mm) wide x 20" (508mm) deep (per cooking head).
- Number of heads: One head can be used for every 12" (305mm) of plate width. Each Top-Side™ cooking head will be positioned over a griddle thermostat to ensure peak efficiency.
- ETL and ETL Sanitation Listed.

■ SAFETY PRECAUTIONS

⚠ WARNING

THIS SYMBOL WARNS YOU THAT SERIOUS BURNS OR OTHER INJURIES MAY RESULT IF SAFETY INSTRUCTIONS ARE NOT FOLLOWED.

- DO NOT SUBMERGE THE TOP-SIDE™ COOKING HEAD IN WATER.
- CLEANING CHEMICALS OR UTENSILS USED FOR CLEANING GRIDDLES WILL DAMAGE OR DESTROY THE POLYMER COOKING SHEET.
- NEVER USE A WATER JET TO CLEAN.

■ INSTALLATION INSTRUCTIONS

This Top-Side™ Cooker must be installed on a Keating griddle only. Failure to do so voids the warranty.

The Top-Side™ Cooker must be installed, inspected, calibrated and serviced by qualified, certified and/or licensed service personnel. Contact your dealer for assistance.

Proper installation will assure top performance. Alterations of any kind to your equipment will void the warranty. Before uncrating, check equipment carefully for damage.

INSTALLATION

Installation must conform with local codes or, in absence of local codes, with the current National Electrical Code ANSI/NFPA 70 or Canadian Electrical Code CAN22.2 as applicable.

IF EQUIPMENT ARRIVES DAMAGED

Keating does not assume responsibility for loss or damage incurred in transit.

IMPORTANT

This merchandise has been thoroughly inspected and carefully packed before leaving our plant. Responsibility for its safe delivery was assumed by the carrier at the time of shipment. Claims for loss or damage to the contents should, therefore, be made upon the carrier, as follows:

CONCEALED LOSS OR DAMAGE

Concealed loss or damage means loss or damage which does not become apparent until the merchandise has been unpacked. The contents may be damaged in transit due to rough handling even though the carton may not show external damage. When the damage is discovered upon unpacking, make a written request for inspection by the carrier's agent within fifteen days of the delivery date. Then file a claim with

the carrier since such damage is the carrier's responsibility. By following these instructions carefully, we guarantee our full support of your claims to protect you against loss from concealed damage.

VISIBLE LOSS OR DAMAGE

Any external evidence of loss or damage must be noted on the freight bill or express receipt, and signed by the carrier's agent. Failure to adequately describe such external evidence of loss or damage may result in the carrier refusing to honor a damage claim. The form required to file such a claim will be supplied by the carrier.

DO NOT RETURN DAMAGED MERCHANDISE TO KEATING. FILE YOUR CLAIM AS STATED.

■ FIRST STEPS

ELECTRICAL CONNECTION

Each Keating Top-Side™ Cooking head is equipped with a 9' (2.74m) neoprene covered, 12 gauge 4mm(2), three wire with ground electrical cord. Each cooking head is rated 4000W, 18 amps, single phase at 220 Volts and is designed to be connected to its own 208-240V single phase electrical supply. For proper connecting and grounding procedures see local codes, the National Electrical Code ANSI/NFPA 70 (latest edition) or Canadian Electrical Code CAN C22.2 (latest edition) as applicable.

⚠ WARNING

THIS APPLIANCE MUST BE EARTHED.

WIRE SIZE

Use the **WIRE SIZE TABLE** to help determine the proper wire size for electrical service hook-up. Use the largest amp value of the three conductors for 3-phase installations when using the table. The amperage values for a product can be found on its serial number tag. Consult the National Electrical Code Handbook for additional information or to help answer questions about wire size selection.

TOP-SIDE™ COOKER - SERIES PRE-2005

WIRE SIZE TABLE

| Conductor Current (Amps up to) | Recommended Wire Size (AWG) |
|--------------------------------|-----------------------------|
| 15 | 14* |
| 20 | 12* |
| 30 | 10* |
| 40 | 8 |
| 55 | 6 |
| 70 | 4 |
| 95 | 2 |
| 125 | 0 |
| 145 | 2/0 |
| 165 | 2/0** |
| 190 | 2/0** |

*For runs greater than 75' up to 125', use the next wire size larger to keep the voltage drop to less than 3%. For runs greater than 125', consult the National Electrical Code Handbook to help determine the proper wire size.

**2/0 wire ambient temperature must be kept at less than 104°F (40°C).

■ OPERATING

▲ CAUTION

Food will cook much faster with a Top-Side™ Cooker than with a griddle alone. Watch food while cooking or use timers to ensure food will not be overcooked.

▲ WARNING

OPERATION OF THE TOP-SIDE™ COOKER SHOULD BE LIMITED TO PERSONNEL THOROUGHLY TRAINED IN OPERATING PROCEDURES.

CONDITIONING THE TOP-SIDE™ MIRACLEAN® SURFACE

The Miraclean® surface has been “seasoned” at the factory. The chrome surface when heated creates a thin layer of chrome oxide which acts as a releasing agent for food products. If you feel you need to recondition the surface, the following instructions should be followed:

1. Follow cleaning procedures on page 4.
2. Heat the Miraclean® to 400°F for one hour.
3. Lower thermostat to 350°F, allowing the Miraclean® to cool to about 350°F, as is evident when griddle cycles on or surface thermometer indicates correct temperature.

4. Lightly coat the Miraclean® surface with griddle oil.

NOTE: Despite the food releasing properties, the chrome surface is not a true “non-stick” surface. For best cooking results and product appearance, use griddle oil for products that require the surface to be conditioned.

COOKING

1. Turn ON/OFF switch to “ON” position.

NOTE: Because of the superior heating characteristics and heat retention properties found in the Miraclean® surface, operating temperatures should be set 10°F to 25°F below conventional griddles.

2. Set thermostat to the desired temperature. Red “ELEMENT ON” light will illuminate when the element is on.

NOTE: To increase temperature, adjust knob clockwise. To decrease, adjust knob counterclockwise.

Figure 3-1

Top-Side™ Cooker Control Panel

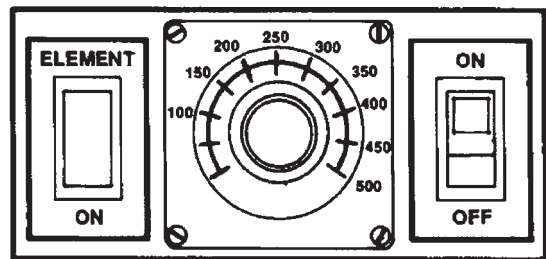

Pre-2005 Model

Maximum thermostat setting 554°F (290°C)

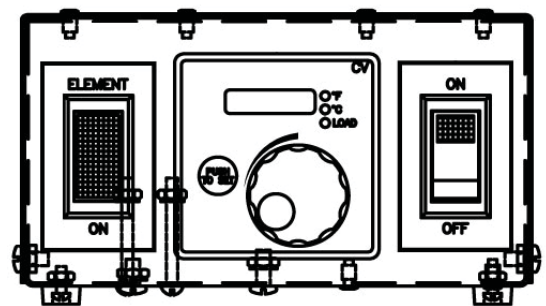

2005 - Current Model

NOTE: The green “Power On” light will be illuminated as long as there is power to the Top-Side™ Cooker.

COOKING HEIGHT ADJUSTMENT

Keating's Top-Side™ Cooker has been designed to allow you infinite height adjustments from 1/8" to 1-1/2" (approximately 3mm to 38mm). An adjusting knob allows fast and precise height adjustment.

Clockwise movement of the knob will increase the spacing; counter clockwise movement will decrease the spacing. Each turn of the adjusting knob represents 1/8" (approximately 3mm) movement.

Experimentation will give you the best cooking height for each type of food product. The cooking head should contact the product firmly to ensure optimum heat distribution without flattening the product.

SHUTDOWN

Turn On/Off switch to "OFF" position.

CLEANING PROCEDURES

A. Keating Cooking Sheets

Clean cooking sheets with a damp soft cloth after each run of product (a Turkish towel works best).

⚠ WARNING

THE COOKING HEAD WILL BE HOT. USE PROPER CARE WHEN CLEANING THE COOKING SHEETS.

End of day cleaning:

Before the griddle is turned off for the day, the cooking sheets should be cleaned as described below. Wear heat resistant gloves for maximum safety during the entire cleaning procedure.

1. At the end of the day, wipe the cooking sheet in place with a damp soft cloth. Continue wiping until the surface of the cooking sheet is free of any residue.
2. Remove the cooking sheet from the cooking head. Clean the cooking head and the griddle surfaces.
3. Wash the cooking sheet with a mild detergent in warm water and dry thoroughly.
4. If needed, after the cleaning is complete, reverse the cooking sheet and reattach it to the cooking head.

B. Cooking Sheet Clips

To remove the stainless steel cooking sheet clips for cleaning, simply lift them off. They can be cleaned in a dishwasher.

C. Cooking Head

The Miraclean® surface is very durable and with proper care, following the procedures below, will last many years.

1. Scrape Miraclean® surface from front to back with the Keating griddle scraper with Cooking Sheets removed.
2. Clean and polish surface with Keating Klenzer on a damp soft cotton cloth. Wipe off excess Klenzer.

⚠ WARNING

NOTE: BECAUSE OF THE SUPERIOR MIRACLEAN® SURFACE, THE ONLY TOOLS YOU WILL EVER NEED TO CLEAN THE TOP-SIDE COOKING HEAD ARE A DAMP SOFT COTTON CLOTH AND A KEATING SCRAPER.

- NEVER SCRAPE COOKING SHEETS WITH THE SCRAPER.
- NEVER USE A GRIDDLE STONE, BRICK, GRIDDLE SCREEN OR HARSH CHEMICALS TO CLEAN THE COOKING HEAD MIRACLEAN® SURFACE.
- DAMAGE DONE TO THE MIRACLEAN® SURFACE BY GRIDDLE STONE, BRICK, SCREEN OR HARSH CHEMICALS WILL VOID THE WARRANTY.
- THE DAMAGE DONE TO THE MIRACLEAN® SURFACE IS IRREPARABLE.
- NEVER USE ICE TO COOL THE MIRACLEAN® SURFACE. USE OF ICE MAY WARP THE MIRACLEAN® SURFACE.
- USE ONLY KEATING SUPPLIED CLEANING TOOLS AND KLENZER.
- USE ONLY A KEATING STEEL SPATULA.

NOTE: Keating Klenzer MSDS is available on our website.

⚠ CAUTION

DO NOT HACK, CHOP, HIT OR CUT ON THE MIRACLEAN® SURFACE.

You will dent the steel plate under the trivalent chrome. It is even possible to hack two nicks close together and actually tear the Miraclean® surface as the chromium will not stretch. See the sketch showing the side view of a cooking head and how the surface can be damaged. Proper use of the utensils supplied with your Miraclean® Griddle will prevent surface damage.

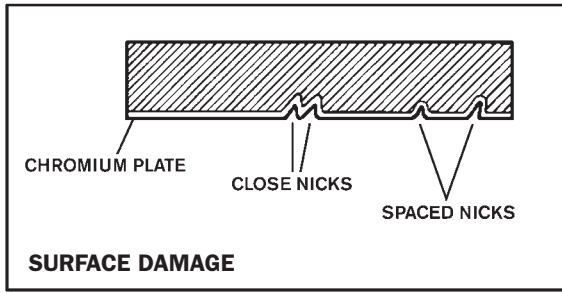

■ MAINTENANCE

WARRANTY REPAIRS

Keating's warranty begins with the date of installation. In the event that your Top-Side™ Cooker, under warranty, needs repairs other than routine maintenance or cleaning, you are required to contact Keating of Chicago (at 1-800-KEATING) before calling a local service company.

NOTE: The cooking sheets are not covered under warranty.

PREVENTIVE MAINTENANCE

Preventive maintenance should be done in daily, weekly, monthly and yearly intervals as necessary. Following preventive maintenance procedures will help keep your Top-Side™ Cooker working efficiently. Proper care and servicing will lead to years of quality performance.

PREVENTATIVE MAINTENANCE CHART

| TIME FRAME | OPERATOR/OWNER |
|--------------------------|---|
| AT LEAST DAILY* | <ul style="list-style-type: none"> • Clean all Cooking Sheets. • Clean Miraclean® griddle surface. |
| AT LEAST WEEKLY* | <ul style="list-style-type: none"> • Clean all surfaces of Top-Side™ Cooker. • Wipe shaft of actuator when fully extended with dry cloth. • Wipe motor/shaft housing with dry cloth. |
| AT LEAST MONTHLY* | <ul style="list-style-type: none"> • Verify thermostat settings. • Review cooking procedures. • Check Cooking Sheets. (Replace if necessary). |
| TIME FRAME | QUALIFIED SERVICE PERSONNEL |
| AT LEAST YEARLY* | <ul style="list-style-type: none"> • Have Top-Side™ Cooker completely checked, calibrated, tested, cleaned, etc. by qualified service personnel. |

*High production facilities should be checked more often. Contact the factory or a local service company to perform maintenance and repairs.

⚠ CAUTION

Damage done to the Miraclean® surface is irreparable and is not covered under Keating Warranty.

INSTALLING A COOKING SHEET

1. Raise Top-Side™ Cooking head completely.
2. Lay the 20" x 24" (508mm x 610mm) cooking sheet on the griddle plate with 20" (508mm) dimension front to back.
3. Lower the Top-Side™ Cooker head onto the cooking sheet, ensuring that the sheet is centered under the head, the front edge of the sheet is even with the front edge of the head, and the sides of the sheet are parallel to the side of the head.
4. Fold both edges of the cooking sheet over the head. While gently pulling the right side of the sheet to remove any slack, firmly push the cooking sheet mounting clip onto the right side mounting rib on top of the head.
5. Repeat process on the left side.
6. Reverse the process to remove the cooking sheet.

TIPS ON PROPER HANDLING AND USE OF COOKING SHEETS

Cooking sheets should NEVER:

- Be folded or creased. Be touched with sharp objects.
- Come in contact with griddle scrapers or abrasive pads.
- Be placed under other equipment or objects.

Cooking sheets should ALWAYS:

- Be wiped with a damp soft cotton cloth after each run to remove any product residue.
- Be cleaned after the griddle is shut down for the day.

The time to change a cooking sheet is when:

- Product starts sticking to the sheet.
- Too much carbon build-up causes a product appearance, cooking or taste problem.
- The head surface is cool.
- The sheet is torn or ripped.

⚠ WARNING

THE TOP-SIDE™ COOKING HEAD AND GRIDDLE PLATE ARE HOT - USE PROPER CARE WHEN CHANGING THE COOKING SHEETS.

LEVELING OF COOKING HEAD(S)

The Cooking Heads were leveled at the factory.

NOTE: For best results, level griddle before checking. Adjust legs or stand casters to level griddle.

REMOVAL OF COOKING HEAD

NOTE: To identify parts, refer to page 10.

1. Turn off griddle and disconnect Top-Side™ Cooker electric power.
2. Remove the cooking sheet by lifting off cooking sheet mounting clips.
3. Place a layer of soft cloth and then a layer of cardboard onto griddle plate under cooking head to protect Miraclean® surface.
4. Raise cooking head completely to release tension on cooking head support pin. Remove support pin and its cotter pin and carefully lower cooking head to protected griddle surface.

⚠ WARNING

The cooking head is not supported after the cooking head support pin has been removed. If dropped the weight of the cooking head when unsupported will cause damage to the griddle surface or injury to personnel.

5. Do not turn the support pin in either direction.
6. To reattach the cooking head to the ram lift arm, raise cooking head completely and replace cooking head support pin. Insert a new stainless steel cotter pin to secure support pin, holding support pin to keep it from spinning.
7. Replace cooking sheet. See - “Installing a Cooking Sheet”.

■ SERVICE DIAGNOSIS

A properly adjusted Keating Top-Side™ Cooker, with no load, will cycle “ON” approximately every 5-1/2 to 6-1/2 minutes. Each cycle will last 40 seconds, ensuring that the temperature setting is held within a narrow range.

TROUBLE SHOOTING

The following diagnosis is only to be used as a guide to qualified service personnel. Keating recommends that you use a qualified & licensed service company. (Equipment still under warranty requires it.) Call 1-800-KEATING if you need assistance in locating a qualified service company.

NOTE: To correctly and quickly diagnose the system, the chart below should be followed in sequential order.

TROUBLE SHOOTING CHART

| PROBLEM | PROBABLE CAUSE | SOLUTION |
|---|---|---|
| Power On light does not come on | <ul style="list-style-type: none"> a. No electricity to Top-Side™ Cooker. b. On/Off switch is faulty. | <ul style="list-style-type: none"> a. Connect Top-Side™ Cooker to an approved source of power. b. Replace On/Off switch. |
| Element On light does not illuminate and Cooking Head will not heat | <ul style="list-style-type: none"> a. Connections to thermostat are loose or thermostat is faulty. b. Connections to thermostat temperature probe are loose or probe is faulty. c. Hi-Limit has tripped or Hi-Limit is faulty. NOTE: Hi-Limit is self-resetting. d. Connections to Hi-Limit are loose or Hi-Limit is faulty. e. Connections to contactor are loose or contactor is faulty. f. On/Off switch is faulty. | <ul style="list-style-type: none"> a. Check connections and tighten where necessary. If thermostat is faulty, replace it. b. Check connections and tighten where necessary. If probe is faulty, replace it. c. Wait until Cooking Head cools down. If Element On light will not come on Hi-Limit if faulty, replace it. d. Check connections and tighten where necessary. e. Check connections and tighten where necessary. If contactor is faulty, replace it. f. Replace On/Off switch. |
| Element On light does not illuminate but Cooking Head does heat | <ul style="list-style-type: none"> a. Element On light is faulty. | <ul style="list-style-type: none"> a. Replace Element On light. |
| Element On light flashes once whenever power is turned on | <ul style="list-style-type: none"> a. Thermostat temperature probe or wires have shorted out. | <ul style="list-style-type: none"> a. Replace probe and/or wires. Use conductive heat paste when installing new probe. |
| Temperature of Cooking Head is erratic | <ul style="list-style-type: none"> a. If erratic, thermostat is faulty. | <ul style="list-style-type: none"> a. Replace thermostat. |

THERMOSTAT REPLACEMENT KIT PART #057138) MOUNTING AND WIRING INSTRUCTIONS

New Thermostat Mounting and Wiring Instructions

1. After removing the old thermostat, drill four larger holes for mounting new housing (See Figure A). After drilling holes, remove any metal filings from inside the unit.
2. Feed the female ends of the four new wires from the inside to the outside of the unit through the old thermostat's mounting hole.
3. Connect the male ends of the four new wires to the female ends of the wires that came off the old thermostat (L1, L2, COM. and N.O.).
4. Feed the new sensor wire through the old thermostat's mounting hole.
5. Remove the two spade connectors that are attached to the unit thermostat's sensor wire.
6. Strip 3/8" of insulation from each of the four ends of the thermostat's sensor wires.
7. Place shrink tubing on both leads of the thermostat's sensor wire.
8. Attach the two pairs of thermostat wires using butt connectors (See Figure C wiring diagram next page).
9. Shrink the tubing over the butt connectors on the thermostat's sensor wire.
10. Mount new housing to the control panel.
11. Connect all six wires to the new thermostat (See Figure C wiring diagram next page).
12. Place the new thermostat in the housing and tighten the four screws (See Figure B).

New Thermostat Operating Instructions

Operating

When the thermostat is powered up, the display will show the set operating temperature. To change the operating temperature, push and hold the "PUSH TO SET" button and turn the adjustment knob until the desired temperature is displayed. Release the button to lock in the setting.

Temperature offset

To change the offset, power off the unit. Push and hold the "PUSH TO SET" button, re-apply power to the unit while still holding the button down. Turn the adjustment knob to the desired amount of offset, release the button to lock in the setting.

Adjust the setting to a positive number if the cooker's temperature is higher than the set temperature. Adjust the setting to a negative number if the cooker's temperature is lower than the set temperature.

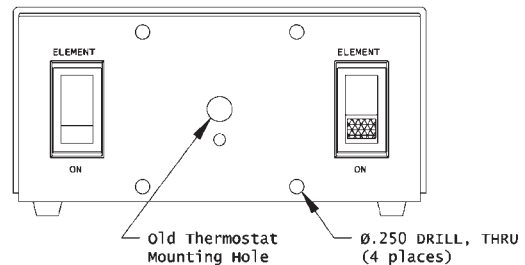

Figure A
Location of old thermostat mounting hole and where new holes should be drilled.

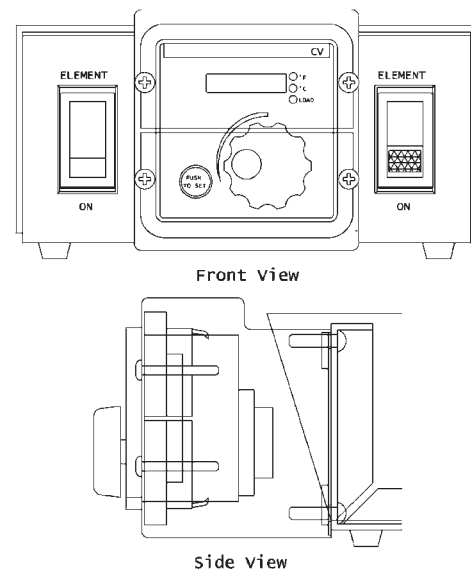
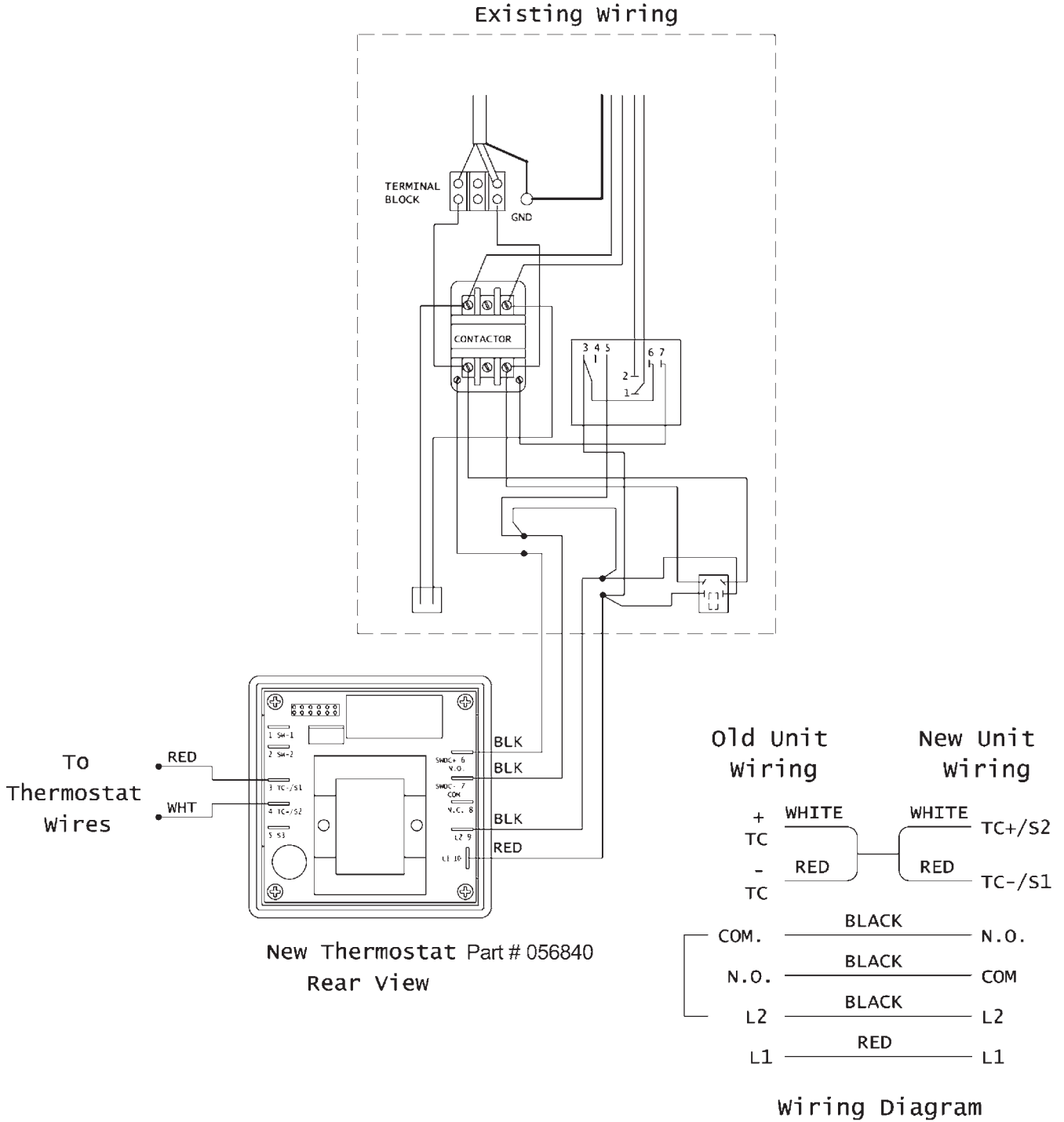

Figure B
New Thermostat Housing and Control Panel

THERMOSTAT REPLACEMENT KIT PART #057138) MOUNTING AND WIRING INSTRUCTIONS (cont.)

Figure C

Wiring Diagram



■ ORDERING PARTS

Parts may be ordered by calling 1-800-KEATING or your local Keating service company. We recommend using genuine Keating Replacement Parts - engineered and manufactured specifically to meet exact specifications and requirements for Keating equipment.

Refer to the Keating Top-Side™ Cooker Limited Warranty for complete service and ordering information.

The model/serial plate for each cooking head is located on the control panel assembly. The serial and model numbers are necessary when ordering.

WARNING AND OPERATING PLATES

All warning and operating plates on the Keating MIRACLEAN® Electric Griddle should be in place at all times. If plates are damaged or lost, replace them immediately.

TOP-SIDE™ COOKING HEAD (EXPLODED VIEW)

Figure 6-1

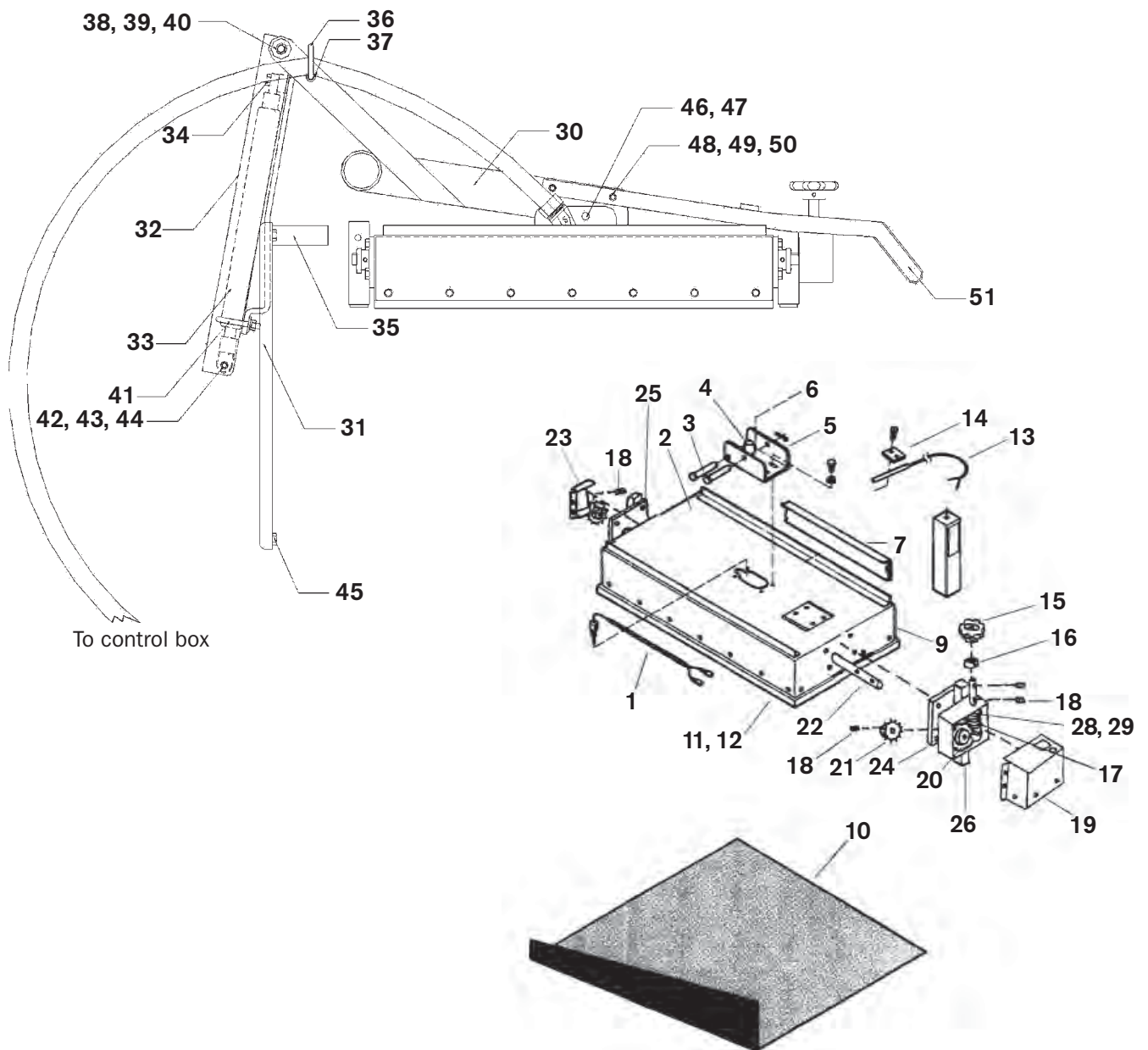

TOP-SIDE™ COOKING HEAD (MANUFACTURED FROM 4/1999 - 2004)

See Figure 6-1

| ITEM | DESCRIPTION | P/N | QTY |
|------|---|---------------|-----|
| 1 | THERMOSTAT TEMPERATURE PROBE KIT | 016659 | 1 |
| 2 | COOKING HEAD (COMPLETE) | 1-800-KEATING | 1 |
| 3 | STOP CLEVIS PIN, S/S | 015164 | 1 |
| 4 | SWIVEL BRACKET WIRE SLEEVE (INCL. IN ITEM 5) | --- | 1 |
| 5 | SWIVEL BRACKET | 028181 | 1 |
| 6 | SWIVEL BRACKET SUPPORT CLEVIS PIN, S/S | 015164 | 1 |
| 7 | COOKING SHEET MOUNTING CLIP | 017316 | 2 |
| 9 | COVER | 1-800-KEATING | 1 |
| 10 | COOKING SHEET (SINGLE SHEET) | 038492 | |
| | COOKING SHEET (PACKAGE OF 12) | 038522 | |
| 11 | MIRACLEAN® COOKING FACE PLATE | --- | 1 |
| 12 | HEATING ELEMENT 4KW, 220V (NOT SHOWN) | 056510 | 1 |
| 13 | HIGH LIMIT PROBE | 015173 | 1 |
| 14 | HIGH LIMIT PROBE MOUNTING PLATE | 014247 | 1 |
| 15 | KNOB | 028622 | 1 |
| 16 | COLLAR | 028486 | 2 |
| 17 | WORM GEAR | 028487 | 1 |
| 18 | 1/4-20 x 1/4" ALLEN SET SCREW | 028501 | 4 |
| 19 | HOUSING COVER | --- | 1 |
| 20 | WORM GEAR WHEEL | 028488 | 1 |
| 21 | SPUR GEAR | 030241 | 2 |
| 22 | SHAFT | 028461 | 1 |
| 23 | REAR COVER | --- | 1 |
| 24 | FRONT HOUSING | --- | 1 |
| 25 | REAR HOUSING | --- | 1 |
| 26 | FRONT PLUNGER | --- | 1 |
| 27 | REAR PLUNGER (NOT SHOWN) | 028522 | 1 |
| 28 | TEFLON WASHER (NOT SHOWN) | 028490 | 1 |
| 29 | FIBER WASHER (NOT SHOWN) | 028500 | 2 |
| 30 | TOP-SIDE COOKER WELD. MANUAL | 052114 | 1 |
| 31 | TOP-SIDE COOKER SPRING SUPPORT WELDMENT | 052266 | 1 |
| 32 | MANUAL TOP-SIDE GAS SPRING LIFT | 052251 | 1 |
| 33 | MANUAL TOP-SIDE COOKER GAS SPRING | 054444 | 1 |
| 34 | SCREW 5/16-18 x 3/4 HEX HEAD ZINC PLATED | 015262 | 1 |
| 35 | TOP-SIDE COOKER SUPPORT BRACE GAS | 052269 | 1 |
| 36 | TOP-SIDE CONDUIT SUPPORT | 052287 | 1 |
| 37 | NUT RIVET 1/4-20 x 5/8 0.332 BODY | 030269 | 1 |
| 38 | WASHER 1/4 ID x 7/8 OD x 1/16 THK NICKEL | 015414 | 2 |
| 39 | SCREW 1/4-20 x 3/4 SERRATED FLANGE LOCK | 032328 | 6 |
| 40 | TOP-SIDE COOKER LIFT ARM ROD | 052117 | 1 |
| 41 | U BOLT WITH MOUNTING PLATE | 052286 | 1 |
| 42 | SCREW 10-24 x 3/8 SERRATED FLANGE LOCK | 032327 | 2 |
| 43 | WASHER 0.190 ID x 0.5630 D x 0.047 THK NICKEL | 013217 | 2 |
| 44 | MANUAL TOP-SIDE COOKER GAS SPRING ROD | 052252 | 1 |
| 45 | NUT 1/4-20 HEX NICKEL PLATED | 016383 | 1 |
| 46 | 3/8-2-1/2 CLEVIS PIN | 015164 | 2 |
| 47 | COTTER KEYS S.S. | 015166 | 2 |
| 48 | 1/4-20 x 3 THREADED ROD | 014226 | 2 |
| 49 | 1/4 STAR WASHER | 017046 | 4 |
| 50 | 1/4-20 ACORN NUT | 015227 | 4 |
| 51 | WELDMENT HANDLE GEAR GAPPING SYSTEM | 033828 | 1 |

TOP-SIDE™ COOKER CONTROL PANEL

| ITEM | DESCRIPTION | P/N | QTY |
|------|--|---------------------|-----|
| 1 | THERMOSTAT REPLACEMENT KIT for PRE 2005 MODELS | 057138 | 1 |
| 2 | THERMOSTAT KNOB | No Longer Available | 1 |
| 3 | THERMOSTAT DIAL PLATE | No Longer Available | 1 |
| 4 | HI-LIMIT CONTROL | 010311 | 1 |
| 5 | HI-LIMIT MOUNTING BRACKET | 016654 | 1 |
| 6 | CONTRACTOR, 50A, 3 POLE | 011184 | 1 |
| 7 | ROCKER SWITCH, LIGHTED, ON/OFF | 038362 | 1 |
| 8 | INSTRUCTION PLATE ON/OFF SWITCH PLATE | 016672 | 1 |
| 9 | INDICATING LIGHT, ELEMENT ON, RED 250V | 036933 | 1 |
| 10 | INSTRUCTION PLATE ELEMENT ON LIGHT PLATE | 016673 | 1 |
| 11 | TERMINAL BLOCK 3 POLE | 002565 | 1 |
| 12 | COVER (WITHOUT SERIAL PLATE) | --- | 1 |
| 13 | CORD, WITHOUT PLUG, 12/3 SJO | 018480 | 1 |
| 14 | PANEL TRAY | --- | 1 |

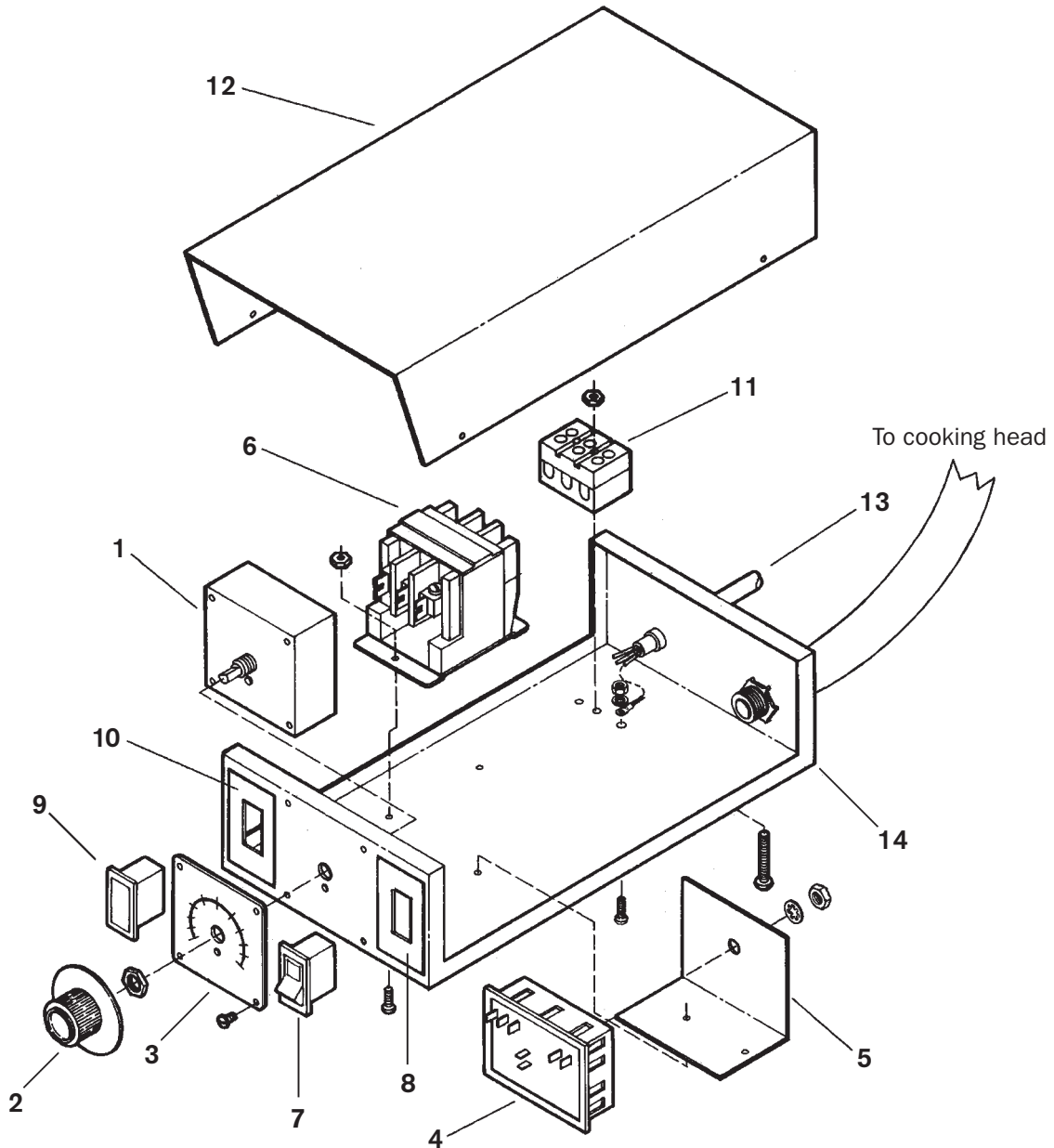

■ WIRING DIAGRAM

TOP-SIDE™ COOKER WIRING DIAGRAM

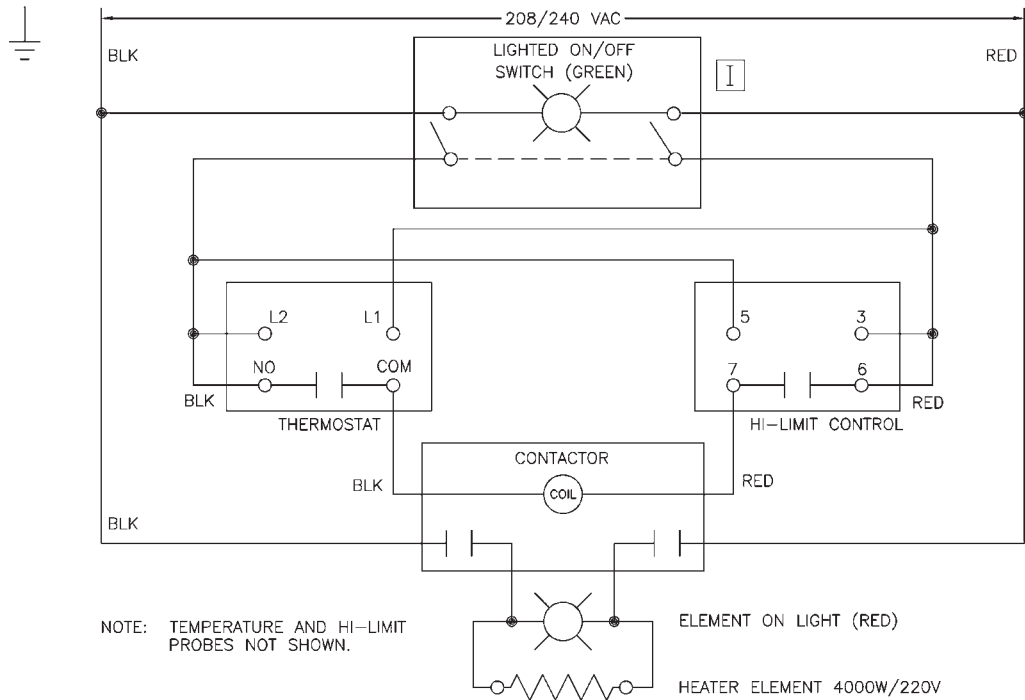
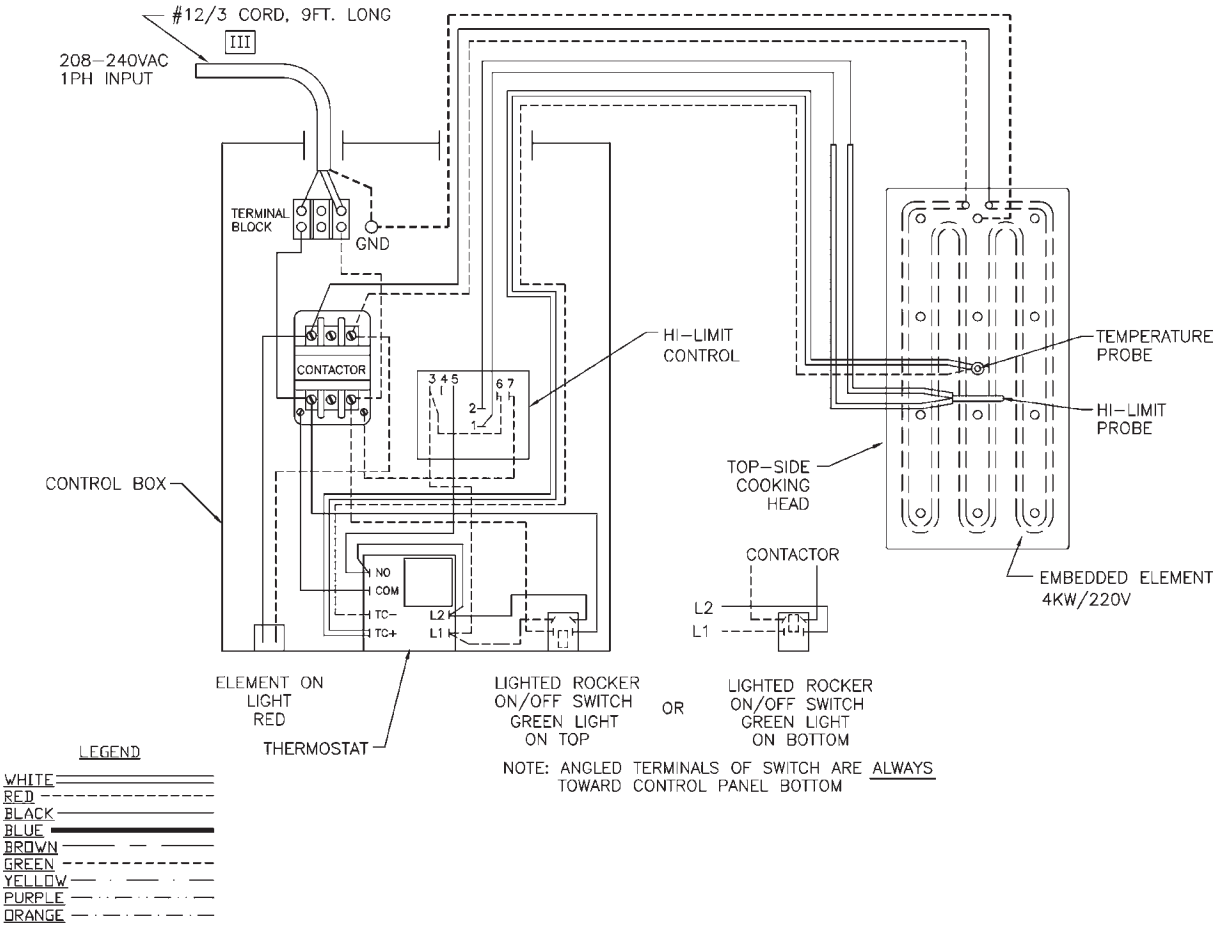



WARRANTY

LIMITED WARRANTY

Keating of Chicago, Inc. ("Keating") warrants to the original purchaser ("Customer"), all new Keating Fryers, Filter Systems, Griddles, Keep Krisp®, Custom Pasta Systems, Top-Side™ Cookers, Computer Timers, Fryer & Pasta Vessels and Keating replacement parts ("products") installed after June 1, 1994 to be free to defects in material or workmanship, subject to the following terms and conditions.

LENGTH OF WARRANTY

All products other than Fryer & Pasta Vessels and replacement parts shall be warranted for a period of one year from the date of original equipment installation. Keating replacement parts are warranted for a period of ninety days from the date of installation. Fryer & Pasta Vessels are warranted as described below.

FRYER & PASTA VESSEL WARRANTY

Fryers purchased after June 1, 1994 carry a prorated vessel warranty on defects in materials or workmanship to the Customer based on the following scale:

| Time from Installation Date | Fryer Vessel Warranty Credit |
|-----------------------------|------------------------------|
| 13-60 months | 100% |
| 61-72 months | 80% |
| 73-84 months | 60% |
| 85-96 months | 40% |
| 97-108 months | 20% |
| 109-120 months | 10% |

The credit for the defective fryer & pasta vessel shall be applied against the cost of the replacement vessel, utilizing Keating's then current price, upon return of the vessel to Keating, (freight to be paid by Keating within the first 12 months only), only during the first 60 months, subject to the limitations described below.

LIMITATIONS OF LIABILITY

In the event of warranty claim or otherwise, the sole obligation of Keating shall be the repair and / or replacement at the option of Keating of the product or component or part thereof. Such repair or replacement shall be at the expense of Keating except that the Customer shall pay the following expenses: all freight and labor expense for Keating replacement parts; for all other products, mileage exceeding 50 miles or travel more than one hour, labor costs of more than one person, overtime rates, truck charges, difference between ground and other mode of transportation, and holiday charges. Any repair or replacement under this Limited Warranty does not constitute an extension of the original warranty for any period for the product or for any component or part thereof. Parts to be replaced under this Limited Warranty will be repaired at the option of Keating with new or functionally operative parts. Keep Krisps and Computer Timers must be returned to Keating for warranty repair or replacement. Field repairs of those items are not authorized.

THE LIABILITY OF KEATING ON ANY CLAIM OF ANY KIND, INCLUDING CLAIMS BASED ON WARRANTY, EXPRESSED OR IMPLIED, CONTRACT, NEGLIGENCE, STRICT LIABILITY OR ANY OTHER THEORIES SHALL BE SOLELY AND EXCLUSIVELY THE REPAIR OR REPLACEMENT OF THE PRODUCT AS STATED HEREIN, AND SUCH LIABILITY SHALL NOT INCLUDE, AND CUSTOMER SPECIFICALLY RENOUNCES ANY RIGHTS TO RECOVER, SPECIAL, INCIDENTAL, CONSEQUENTIAL OR OTHER INJURIES TO PERSONS OR DAMAGE TO PROPERTY, LOSS OF PROFITS OR ANTICIPATED PROFITS, OR LOSS OF USE OF THE PRODUCT.

If any oral statements have been made regarding the Keating products, such statements do not constitute warranties and are not part of the contract sale. This Limited Warranty constitutes the complete, final and exclusive statement with regard to warranties.

THIS LIMITED WARRANTY IS EXCLUSIVE AND IS IN LIEU OF ALL OTHER WARRANTIES WHETHER WRITTEN, ORAL, STATUTORY OR IMPLIED, INCLUDING BUT NOT LIMITED TO ANY WARRANTY OF MERCHANTABILITY OR FITNESS FOR PARTICULAR PURPOSE OR WARRANTY AGAINST LATENT DEFECTS.

EXCLUSIONS

The warranties provided by Keating of Chicago, Inc. do not apply in the following instances:

- Defects arising out of or resulting from improper installation or maintenance, abuse, misuse, modification or alteration by unauthorized service personnel, or any other condition not attributable to a defect in material or workmanship. Proper installation and maintenance are the responsibility of the installer and Customer, respectively. Proper installation and maintenance procedures are prescribed by the Keating Service Manual.
- In the event that the product was damaged after leaving the factory due to flood, fire, other acts of God or accident, damage during shipment should be reported to the carrier and is not the responsibility of Keating.
- In the event the serial number or rating plate has been removed from the product or altered.
- On parts which would normally be worn or replaced under normal conditions, including but not limited to electric bulbs, fuses, interior and exterior finishes, gaskets and radiants.
- With regard to adjustments and calibrations such as leveling, tightening of fasteners or plumbing connections, improper gas pressure or improper electrical supply, the checking of and changes in adjustment and calibrations are the responsibility of the installer. Proper installation procedures are prescribed by the Keating Service Manual.
- In the event of unauthorized repairs or alterations to the Keating product.
- With the use of sodium chloride in pasta vessels or harsh chemicals in fryer or pasta vessels.
- Installation in Household.

OTHER TERMS AND CONDITIONS

The Customer must provide proof of purchase from Keating.

This Limited Warranty is valid in the 50 United States, its territories, and Canada, and is void elsewhere.

Keating products are sold for commercial use only. If any Keating product is sold as a component of another product or used as a consumer product, such Keating product is sold As Is without any warranty.

If any provision of this Limited Warranty is held to be unenforceable under the law of any jurisdiction, such provision shall be inapplicable in such jurisdiction, and the remainder of the warranty shall remain unaffected. Further in such event, the maximum exclusion or limitation allowable under applicable law shall be deemed substituted for the unenforceable provision.

This Limited Warranty shall be governed by and construed in accordance with the laws of the State of Illinois.

TO SECURE WARRANTY SERVICE

All repair services under this Limited Warranty must be authorized by Keating or performed at Keating. Authorization may be obtained by calling 1-800-KEATING within the Continental United States, Alaska, Hawaii, Puerto Rico and Canada during normal business hours (8 a.m. through 5 p.m. Central Time, Monday through Friday). When calling, please have the following information available: (1) name, address and telephone number of the Customer; (2) location of product, if different; (3) name, model number and serial number of the product; (4) installation date; and (5) description of defect. Keating will then issue a service authorization work order number to one of its approved independent servicing organizations, or request the product or part be shipped to Keating for repair or replacement, as appropriate. Any defective part subject to a claim under this Limited Warranty must be shipped freight prepaid to Keating for testing and examination. Keating's decision as to the cause and nature of any defect under this Limited Warranty shall be final.

■ **SERVICE INFORMATION:**

If you have a service related question call **1-800-KEATING**.
Please state the nature of the call; it will ensure speaking with the appropriate person.

Have your serial and model number available when ordering parts.

As continuous product improvement occurs, specifications may be changed without notice.

.....
KEATING LIMITED WARRANTY CARD

PLEASE COMPLETE AND MAIL AT ONCE--WARRANTY IS NOT IN EFFECT UNTIL CARD IS RETURNED, OR COMPLETE THE WARRANTY CARD ON OUR WEBSITE FOR YOUR CONVENIENCE.

COMPANY: _____

ADDRESS: _____

CITY: _____ STATE: _____ ZIP CODE: _____

DEALER NAME: _____

DATE OF PURCHASE: _____ INVOICE #: _____

SERIAL #: _____ MODEL: _____

FRYER GRIDDLE CUSTOM PASTA
 FILTER SYSTEM TOP-SIDE COOKER HOTPLATE

I HAVE READ THE INSTALLATION AND OPERATING INSTRUCTIONS.

SIGNED: _____ DATE: _____



KEATING OF CHICAGO, INC.
8901 West 50th Street
McCook, IL 60525-6001

1-800-KEATING
PHONE: 708-246-3000
FAX: 708-246-3100

Serving Those Who Serve the Very Best®